

# Programme overview **Group 3**

## Concealed hinges

|          |       |               |
|----------|-------|---------------|
| Intermat | Pages | 3.4 – 3.133   |
| Ecomat   | Pages | 3.34 – 3.37   |
| Slide-on | Pages | 3.134 – 3.149 |
| Unimat   | Pages | 3.150 – 3.161 |
| Perfekt  | Pages | 3.162 – 3.169 |

## Single pivot hinges

|                  |       |               |
|------------------|-------|---------------|
| Selekta Pro 2000 | Pages | 3.170 – 3.186 |
| Selekta 4        | Pages | 3.187 – 3.190 |

## Specialty hinges

|  |       |               |
|--|-------|---------------|
| Refrigerator hinges, folding door hinges, fascia hinge, Optimat Plus, screw-on hinges, Excellent cylinder hinge, Stabilo 72/75, Niro 66, Sepa hinge, glass door hinges | Pages | 3.191 – 3.212 |
|--|-------|---------------|

## Programme overview

|  |      |       |
|--|------|-------|
| Butt hinges, surface hinges, piano hinges, swing door fittings, flap hinges, table hinges, special hinges, flap fittings, lift-up flap fittings, swivel fitting Horizon Plus | Page | 3.213 |
|--|------|-------|

# Product overview



## Intermat / Ecomat

Fast-assembly hinges

Pages 3.4 – 3.133



## Slide-on

Concealed hinges

Pages 3.134 – 3.149



## Unimat

Design mini hinge

Pages 3.150 – 3.161



## Perfekt

Concealed hinge  
for display cases and corner cabinets

Pages 3.162 – 3.169

3

# Group 3

3



## Selektapro 2000

Fast assembly hinges  
for office and commercial furniture  
Pages 3.170 – 3.186



## Selektapro 4

Single pivot hinge  
for office and commercial furniture  
Pages 3.187 – 3.190

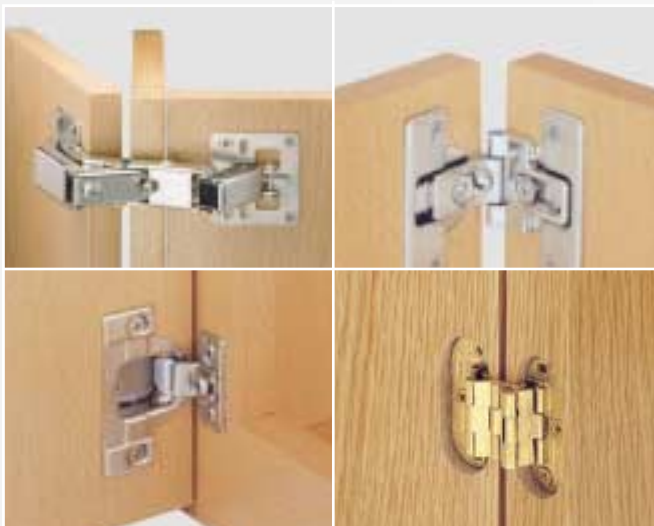

## Specialty hinges

Refrigerator hinges, folding door hinges,  
fascia hinge, Optimat Plus, screw-on hinges,  
Excellent cylinder hinge, Stabilo 72/75,  
Niro 66, Sepa hinge, glass door hinges  
Pages 3.191 – 3.212



## Programme overview

Butt hinges, surface hinges, piano hinges,  
swing door fittings, flap hinges, table hinges,  
special hinges, flap fittings, lift-up flap fittings,  
swivel fitting Horizon Plus  
Page 3.213

# Intermat – maintenance

**Intermat** is sophisticated hinge technology made by Hettich. Its external appearance indicates quality. Long service life and great ease of use round off the hinge profile.

**Concealed latch**  
simple, safe, reliable

**Eccentric depth adjustment**  
Exact door depth alignment  
without loosening screws

**Superflat cup design**  
Huge product range with  
over 100 mounting options

**Eccentric height adjustment**  
Exact door height alignment  
without loosening screws



# -free, robust, quiet, reliable!

3 series for 3 standards...

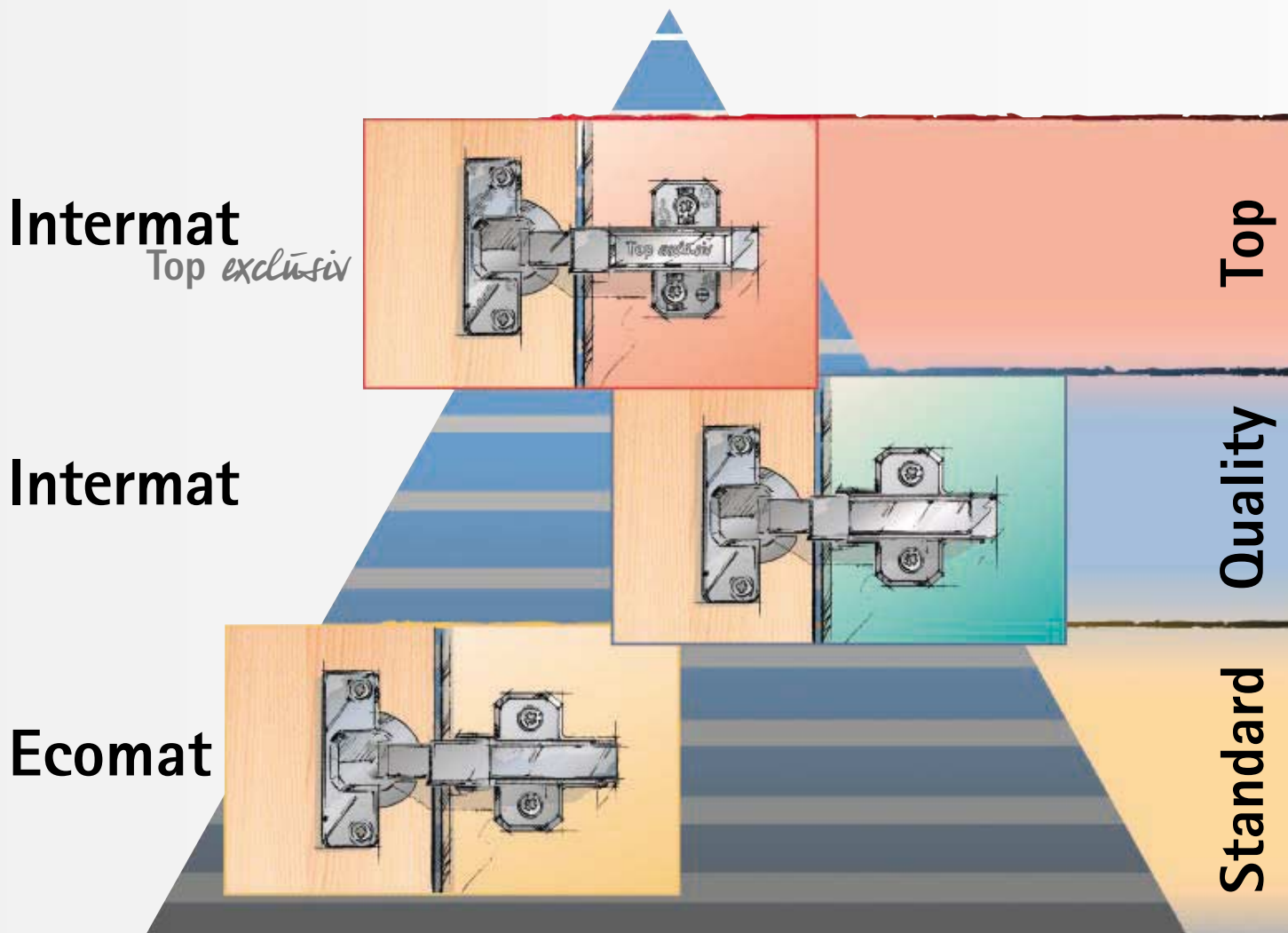

# Intermat- and Ecomat hinges



Intermat 9945

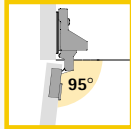

Intermat Konsul 5

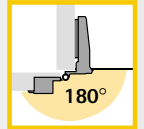

Intermat 9930/9930 FIX

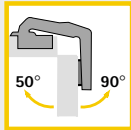

Intermat 9944 Alu

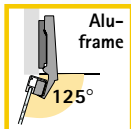

Intermat 9936 Alu

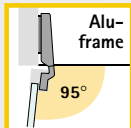

Intermat 9904 W45

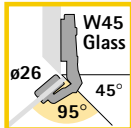

Intermat 9924 W45

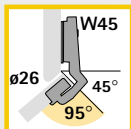

Intermat 9904 W30

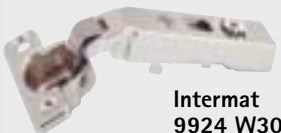
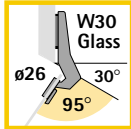

Intermat 9924 W30

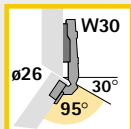

Intermat 9904

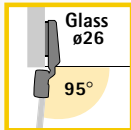

Intermat 9944 W-30/  
9944 W-30 FIX

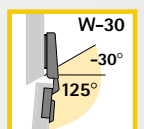

Intermat 9924

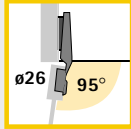

Intermat 9944 W-45/  
9944 W-45 FIX

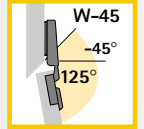

Hettich Direkt Top

3

...the most extensive Hettich range ever!

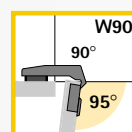
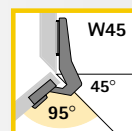
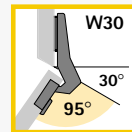
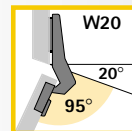
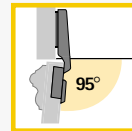
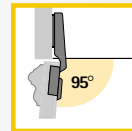
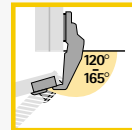
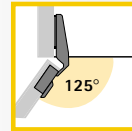
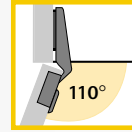
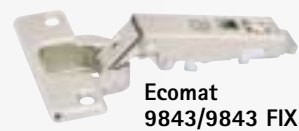
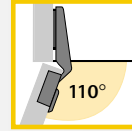
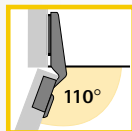

24 hinge models for every application.  
That makes a total of 214 hinges.  
All of them can be used with the  
9000 mounting plate system.

3

# Intermat

Top technology for every hinge type



The Intermat range is complete and offers the perfect solution for every application.

- 95°, 110°, 125° and wide-angle hinges
- Versions for positive and negative carcass angles
- Glass, folding and aluminium frame door hinges
- Standard and "Fix" cups and the "Flash" fast assembly system

3

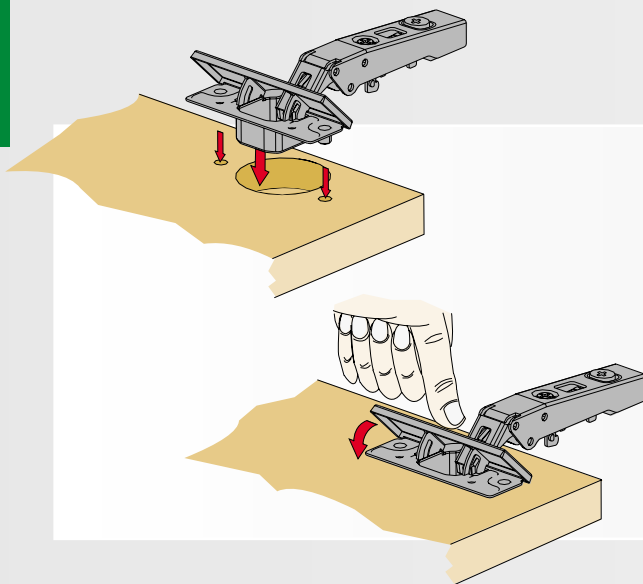

## Intermat Fix

Hinge mounting that's simply unique and uniquely simple!

Insert hinge into door drill hole and press down cover cap by hand – no tools required. That's it!

If the hinge ever has to be replaced, open the cover cap and undo the hinge head.

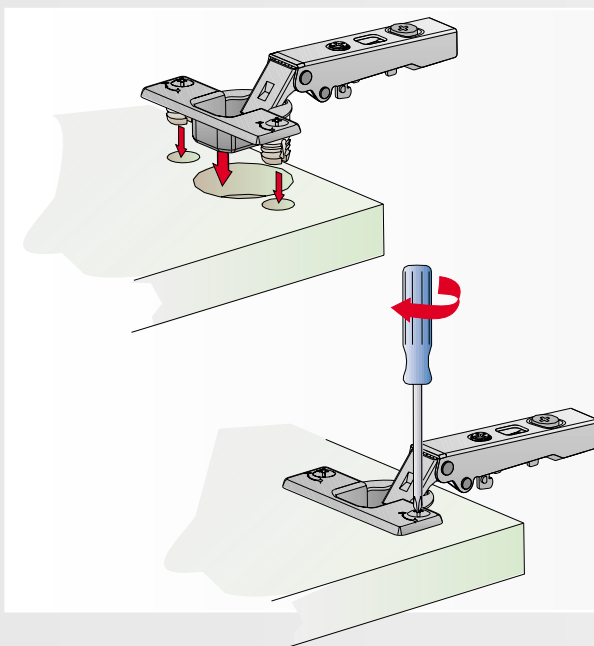

## Intermat FLASH

Fast hinge assembly

- Fit the hinge cup over the hole in the door and tighten the expanding screws
- The hinge is firmly fixed in place.

Visible symbols clearly depict the fixing function. The double function provides a secure connection:

The socket expands and at the same time the screw threads pull the cup firmly against the door surface.

The Flash-System offers advantages in production, storage and transport. The predrilled doors can be ready surface coated and stacked flat. The simple disassembly of the Flash-System means that materials can be efficiently sorted for recycling.



## Interimat – all cup variants at a glance

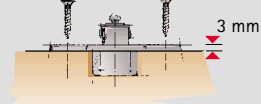
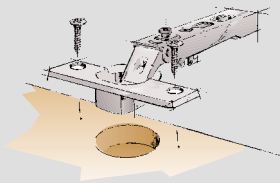

**Cup T 42**  
Screw-on

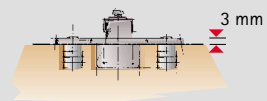
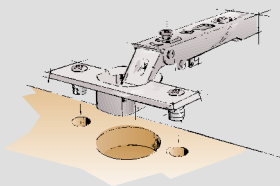

**Cup T 43**  
Press-in

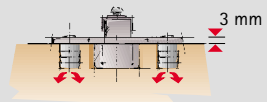
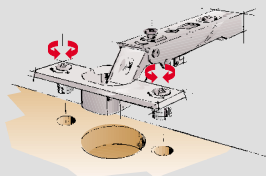

**Cup Flash**  
Fast assembly

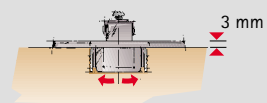
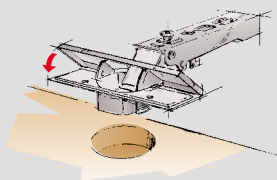

**Cup T FIX**  
Toolless  
fast assembly

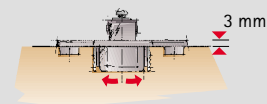
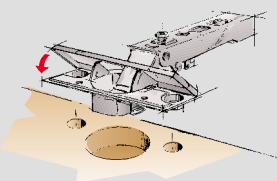

**Cup TH FIX**  
Toolless  
fast assembly

# Intermat Top *exclusiv*

Discover the **secret**  
of perfect **hinge technology**



**Intermat Top *exclusiv*** from Hettich is the ultimate in hinges: quiet, powerful, maintenance-free, aesthetically perfect, timeless and particularly valuable.

Equipped with first-class technology that has been tried and tested, the hinge meets the very highest demands in respect of convenience and technology, functionality and durability.

**Intermat Top *exclusiv*** with infinitely variable eccentric depth adjustment is naturally available in various cup versions.

## A revelation for exclusive furniture ...

# Precise, quiet, timeless



**Extremely sturdy and durable**  
Four robust guide levers move smoothly and silently when the hinge opens and closes.  
**Precision-work from Hettich.**



3



## **Fits precisely in all furniture**

The cup is made of robust diecast zinc. With high-quality, matt silk surface finish. Quick and easy installation is guaranteed by precise centering in the hole.



## **Patented innovation**

The patented wing mounting plate »Hettich Direkt Top« with new, infinitely variable eccentric height adjustment: one turn of the screwdriver is enough to obtain perfect front panel alignment – infinitely, directly, rapidly and with millimetre accuracy.



## **Greater freedom for attractive furniture designs**

The new lever system ensures that the door closes absolutely tight. In other words, a full opening angle with virtually no reveal. Even for doors up to 19 mm thick.

# Intermat / Ecomat

with Silent System



Silent System -

the perfect cushioning system

**that controls furniture  
door closure gently  
and quietly.**

### Convenience for the customer

The perfect solution for every application:

- Clip-on
- Screw fixing
- Drill-in

# Silent System

## Variable technology for "silent doors".

### Clip-on door buffer

- Simply clips on
- No additional steps in manufacture
- A simple screw enables step-less adjustment of the cushioning function
- Toolless assembly and disassembly
- Door buffer identical for left and right-hand mounted doors
- Can be retrofitted to tried and tested Intermat and Ecomat hinges



### Screw-on door buffer for overlay and inset doors

- Fastens to upper or lower cabinet panel
- No additional steps in manufacture
- A simple screw enables step-less adjustment of the cushioning function
- Can be retrofitted to tried and tested Intermat and Ecomat hinges



### Drill-in door buffer for overlay doors

- Fits almost invisibly into the lower or upper panel: discreet, yet efficient
- Can also be retrofitted to existing cabinets
- To fit, simply insert into a 10 mm dia. hole
- For use with Intermat or Ecomat hinges



# Hettich Direkt Top

The patented screw-on cross mounting plate with eccentric height adjustment!



Hettich Direkt is a clever method of fixing mounting plates, used especially for half overlay mounting. The screw holes are slightly offset so that when mounting to a **centre panel with a thickness from 15 mm**, a firm fixing with high tear-out strength is guaranteed.

Cost savings during assembly:  
The "Hettich Direkt" mounting plate is provided with **pre-mounted locating pegs and asymmetrically positioned special screws**. It is simply inserted into the  $\varnothing 5$  mm hole line and fits firmly even before being screw fixed.

This simplifies assembly not only of the centre panel, but also in the cabinet area.

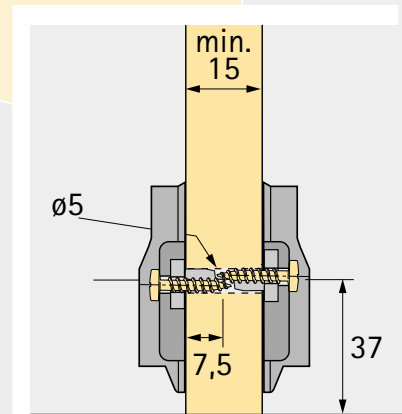
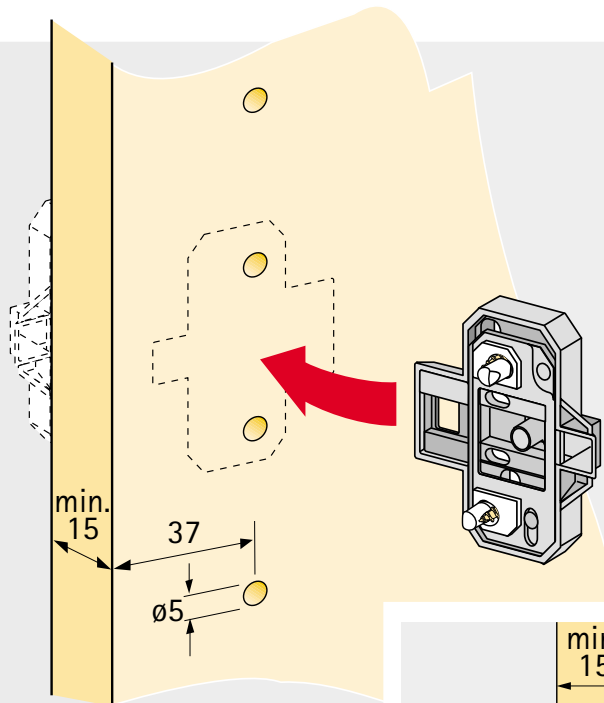
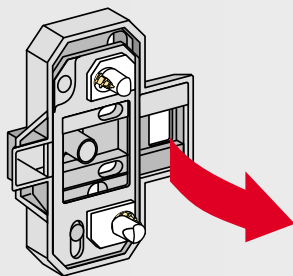

## The Hettich Direkt Top fixing system

# Hettich Top

The screw-on cross mounting plate with pre-mounted self-tapping screws and eccentric height adjustment!



Cabinet doors can be aligned with a hand movement - it's no problem with the eccentric adjustment system from Hettich.

A perfect reveal cannot be achieved more quickly, directly or indeed more safely, as the fastening screws do not need to be released beforehand.

The **height adjustment** is realized via the integrated eccentric in the mounting plate. The five versions available from Hettich cover different mounting variants. The **depth adjustment** of a cabinet door is done through the eccentric in the hinge.

Only a screwdriver is required to precisely adjust the height and depth. A **short turn** and all doors form a perfect line.

3

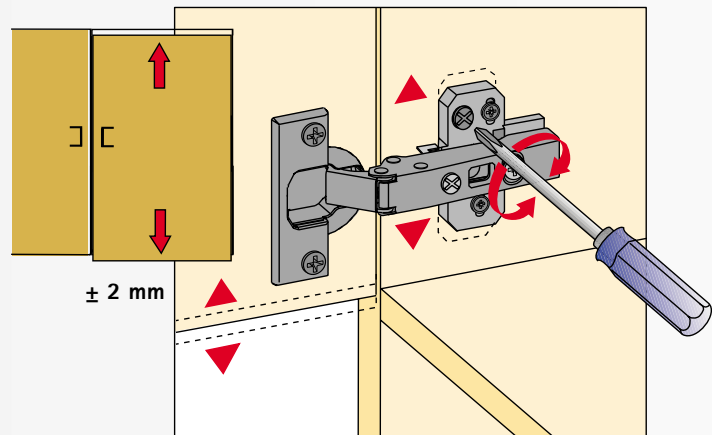
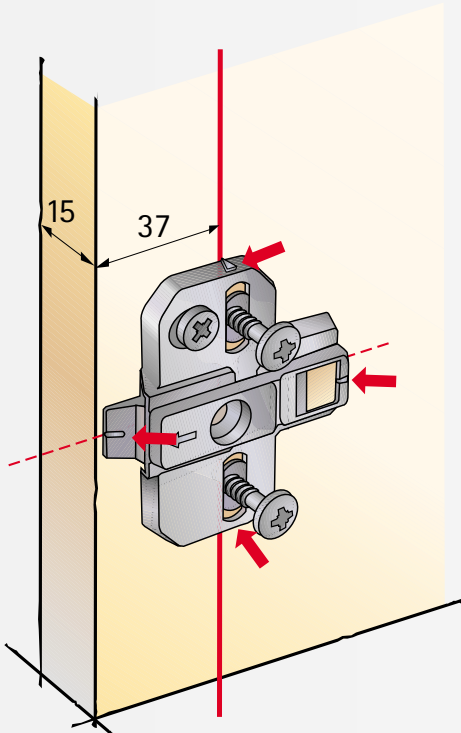



## Mounting options

There are three basic methods of mounting hinges

### Full overlay

In this configuration, the door is positioned in front of a side wall of the cabinet. The reveal at one side is such that the door can be opened safely.

0 mm cranking

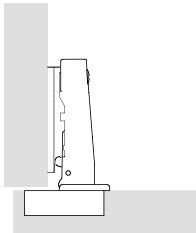

### Half overlay

In this configuration, two doors are positioned in front of the middle wall of a cabinet. The distance between the doors is the total required reveal. The door overlay is reduced which necessitates the use of cranked hinges.

9,5 mm cranking

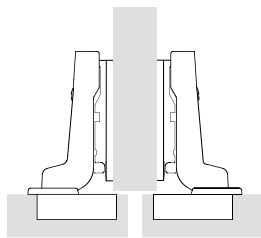

### Inset

In this configuration, the door is positioned inside the side wall of the cabinet. A reveal is required for opening the door. This configuration necessitates the use of heavily cranked hinges.

16 mm cranking

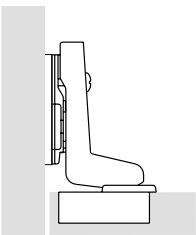

## Cup distance C

The cup distance C is the distance between the edge of the door and the edge of the cup hole. The maximum cup distance depends on the hinge in question.

**The larger the cup distance, the smaller the required minimum reveal.**

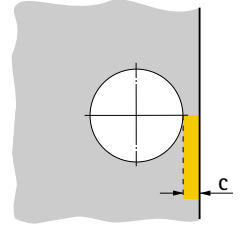

## Overlay (Door overlay)

The overlay is the distance by which the door projects over the cabinet front.

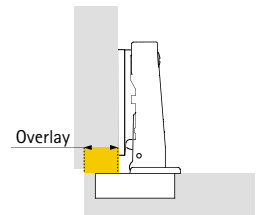

## Reveal

The reveal is the distance between the outer edge of the door and the outer side of the cabinet (full overlay), the distance between two doors (half overlay), the distance between the outer edge of the door and the inner side of the cabinet (inset).

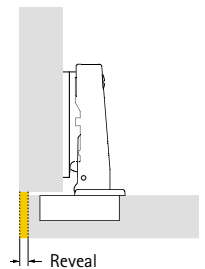

## Number of hinges per door:

Door width, door height, door weight plus material quality of the door are key factors for determining the required number of hinges. In practice, these factors are very variable. The numbers given in the diagram are for reference only. A trial mounting is recommended if in doubt.

For stability, the distance between hinges should be chosen as large as possible.

### X = distance between two hinges

(Reference values for 19 mm thick chipboard with a density of 750 kg/m<sup>3</sup>)

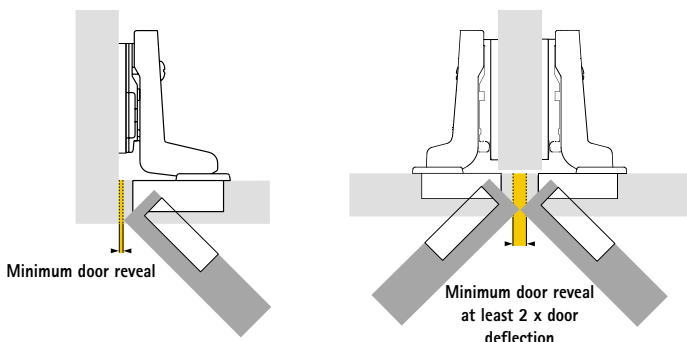
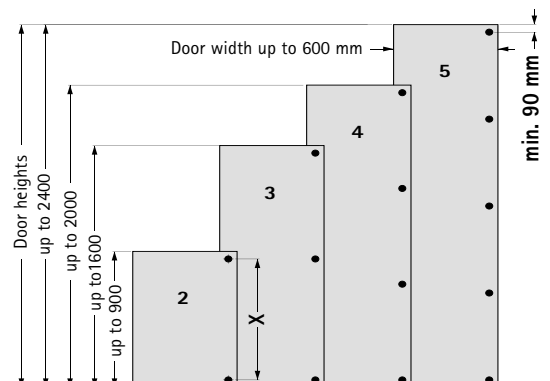

## Minimum door reveal

The minimum reveal, also called door deflection, is the space required for opening a door. The amount of reveal depends on the cup distance C, the door thickness and the hinge type. Chamfered door edges reduce the reveal required.

The required minimum reveal can be derived from the table provided for each hinge.

### Minimum door reveal for half overlay

For half overlay configurations, the total reveal between the doors must be chosen to correspond to twice the door reveal. Both doors can then be opened at the same time.

# Intermat

## Fast-assembly hinges

### Technical information

#### Distance

Mounting plates are available in various thicknesses with an effective height characterized by the value of the distance.

Starting point for calculating the required distance is the selected hinge with defined door overlay.

Using planned cup distance and door thickness, first read the required reveal value from the table. If this value is too large for the desired overlay, it can be reduced either by increasing the cup distance C or by chamfering the door edge.

Once the door reveal and cup distance C have been defined, the mounting plate distance can be derived from the table.

If the distance value deviates from the actual mounting plate distance shown in the catalogue, the difference can be compensated by turning the overlay adjustment screw.

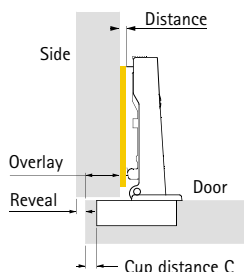

Example: Intermat 9943 - 0 mm cranking

Fixed sizes    **Overlay**    15 mm  
                          **Cup distance** 4,5 mm  
                          **Distance of** 2,5 mm

The table shows a

Select a mounting plate with a distance of 1,5 mm and reduce the overlay by 1 mm by turning the overlay adjustment screw.

| Cup distance C mm | Overlay mm    |     |     |     |     |     |     |     |     |     |
|-------------------|---------------|-----|-----|-----|-----|-----|-----|-----|-----|-----|
|                   | 10            | 11  | 12  | 13  | 14  | 15  | 16  | 17  | 18  | 19  |
|                   | Distance D mm |     |     |     |     |     |     |     |     |     |
| 3                 | 6,0           | 5,0 | 4,0 | 3,0 | 2,0 | 1,0 | 0,0 |     |     |     |
| 4                 | 7,0           | 6,0 | 5,0 | 4,0 | 3,0 | 2,0 | 1,0 | 0,0 |     |     |
| 4,5               | 7,5           | 6,5 | 5,5 | 4,5 | 3,5 | 2,5 | 1,5 | 0,5 |     |     |
| 5                 | 8,0           | 7,0 | 6,0 | 5,0 | 4,0 | 3,0 | 2,0 | 1,0 | 0,0 |     |
| 6                 | 9,0           | 8,0 | 7,0 | 6,0 | 5,0 | 4,0 | 3,0 | 2,0 | 1,0 | 0,0 |

Overlay adjustment - 4 mm, + 0,5 mm

#### Door adjustment

##### Overlay adjustment

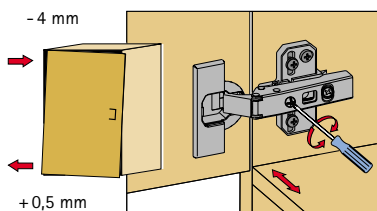

Turn screw **clockwise**:  
 Door overlay **decreases** (-).  
 Turn screw **anticlockwise**:  
 Door overlay **increases** (+).

##### Depth adjustment

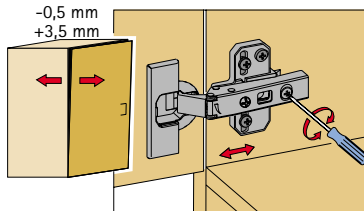

Direct, variable depth adjustment with the eccentric screw

##### Height adjustment

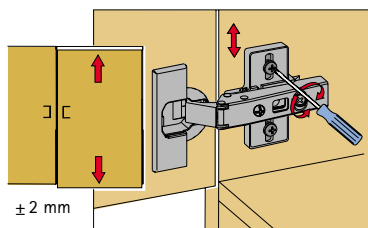

Using **height-adjustable mounting plates** makes it possible to align the exact door height.

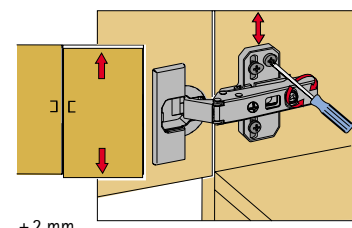

Direct, variable height adjustment with eccentric screw

**When using Ecomat and linear mounting plates with eccentric height adjustment, the hinge has to be moved out of the way in order to adjust the height.**

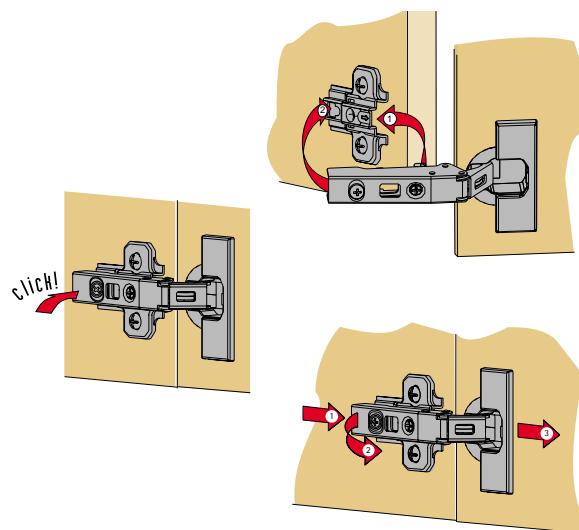

#### Intermat

##### Snap-on assembly, disassembly

Characteristic for Intermat hinges is the ergonomic **snap-on assembly**. The hinge is slipped into the front of the mounting plate (1), then a light finger pressure and the hinge arm latches onto the mounting plate (2) with an audible click.

The hinge arm is now securely clamped, via five points, with zero play.

Doors are clipped on **zipper style from top to bottom - the top hinge alone is capable of taking the total weight of the door.**

**Disassembly** is carried out in the opposite direction **from bottom to top.**

The hinge is unlatched by pressing lightly on latch (1) which is hidden under the side arm for security reasons. In one movement, the hinge arm is lifted off the mounting plate (2) and the door is removed from the cabinet (3).

# Silent System for Intermat and Ecomat hinges

## Technical information

3



### Clip-on door buffer Silent System

for overlay doors (cranking 0 and 9,5 mm), inset doors (cranking 16 mm) and for use with Intermat and Ecomat hinges.

A simple screw enables step-less adjustment of the cushioning function.

### Application for clip-on door buffer

| Hinge                        | Cranking |        |       |
|------------------------------|----------|--------|-------|
|                              | 0 mm     | 9,5 mm | 16 mm |
| Intermat Top <i>exclusiv</i> | 0 mm     | 9,5 mm | 16 mm |
| Intermat 9943                | 0 mm     | 9,5 mm | 16 mm |
| Intermat 9944                | 0 mm     | 9,5 mm |       |
| Intermat 9936                | 0 mm     | 9,5 mm | 16 mm |
| Ecomat 9843                  | 0 mm     | 9,5 mm | 16 mm |

### Assembly

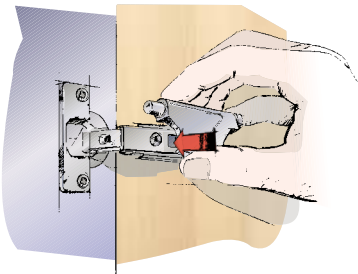

### Disassembly

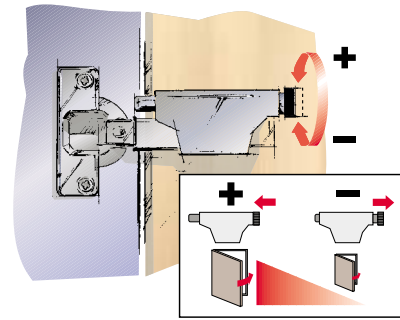
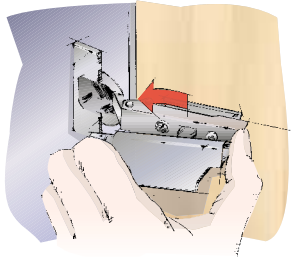

### Screw-on door buffer Silent System

for overlay doors and for use with Intermat and Ecomat hinges.

A simple screw enables step-less adjustment of the cushioning function.

### Assembly

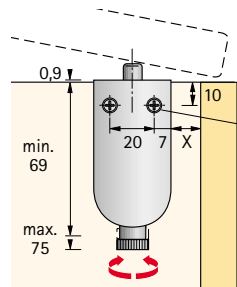
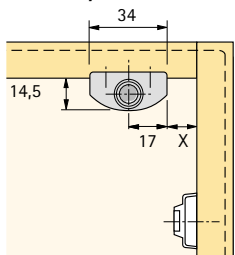

Countersunk screw  
ø 4 x 17 mm

Dimension X = distance from mounting plate + hinge cranking

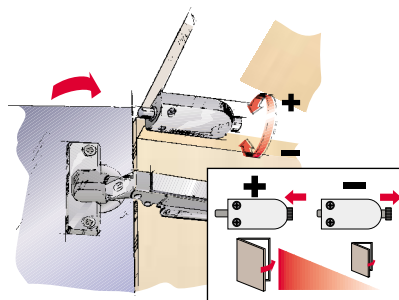

### Application for screw-on door buffer Silent System

- Intermat Top *exclusiv*
- Intermat 9943
- Intermat 9944
- Intermat 9956
- Intermat 9936
- Intermat 9936 W20
- Intermat 9936 W30
- Intermat 9936 W45
- Intermat 9936 W90
- Ecomat 9843



### Screw-on door buffer Silent System

for use with an inset door with Intermat and Ecomat hinges.

A simple screw enables step-less adjustment of the cushioning function.

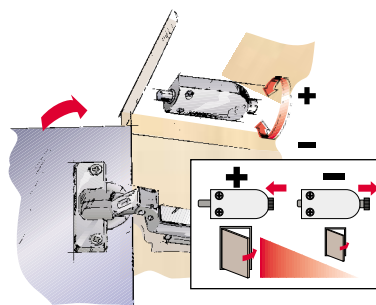

#### Application for inset screw-on door buffer Silent System

- Intermat Top *exclusiv*
- Intermat 9943
- Intermat 9944
- Intermat 9956
- Intermat 9936
- Intermat 9936 W20
- Intermat 9936 W30
- Intermat 9936 W45
- Intermat 9936 W90
- Ecomat 9843



#### Assembly

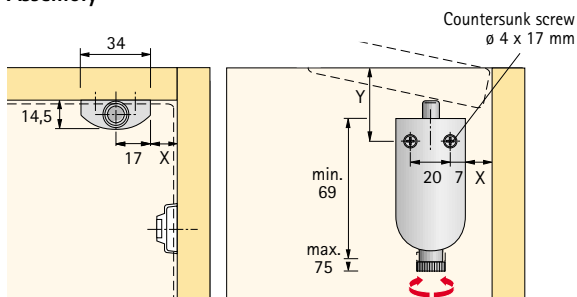

Dimension X = distance from mounting plate + hinge cranking  
Dimension Y = door thickness + 11

#### Recommended number of buffers per door

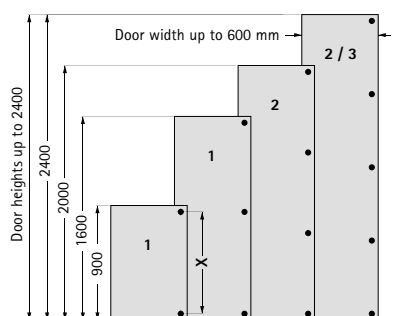

Guide values for 19 mm chipboard panels with a density of 750 kg/m<sup>3</sup>



### Drill-in door buffer Silent System

for overlay doors and for use with Intermat and Ecomat hinges.

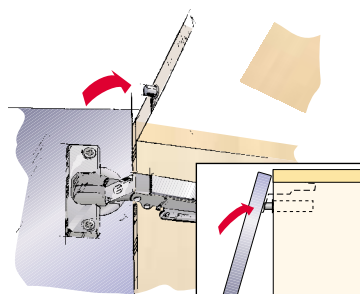

#### Application for drill-in door buffer Silent System

- Intermat Top *exclusiv*
- Intermat 9943
- Intermat 9944
- Intermat 9956
- Intermat 9936
- Intermat 9936 W20
- Intermat 9936 W30
- Intermat 9936 W45
- Intermat 9936 W90
- Intermat 9936 Alu
- Intermat 9944 Alu
- Ecomat 9843

#### Assembly

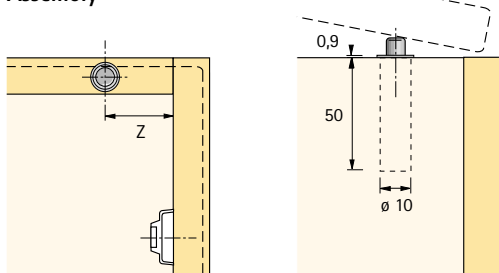

Dimension Z = 17 + distance from mounting plate + hinge cranking

#### Recommended number of buffers per door

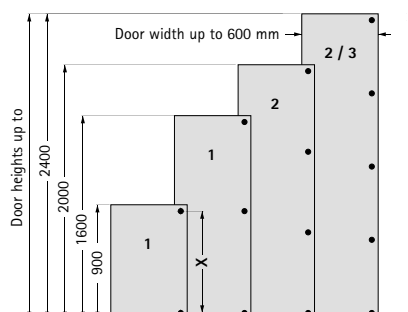

Guide values for 19 mm chipboard panels with a density of 750 kg/m<sup>3</sup>

# Intermat

## Fast-assembly hinges ... ... quality to meet different needs

The quality of the concealed hinges is constantly monitored during production.

In addition, some hinges are monitored externally by the LGA quality control department. This is documented by quality certificates like the example shown for the Intermat hinge 9943 with test number "457".

These externally defined standards are accompanied by Hettich's own tests adapted to the requirements of individual hinge types.

They comply with the different quality standards of different markets and industries.

The schematics below are examples of the tests to which Hettich hinges are subjected.



3

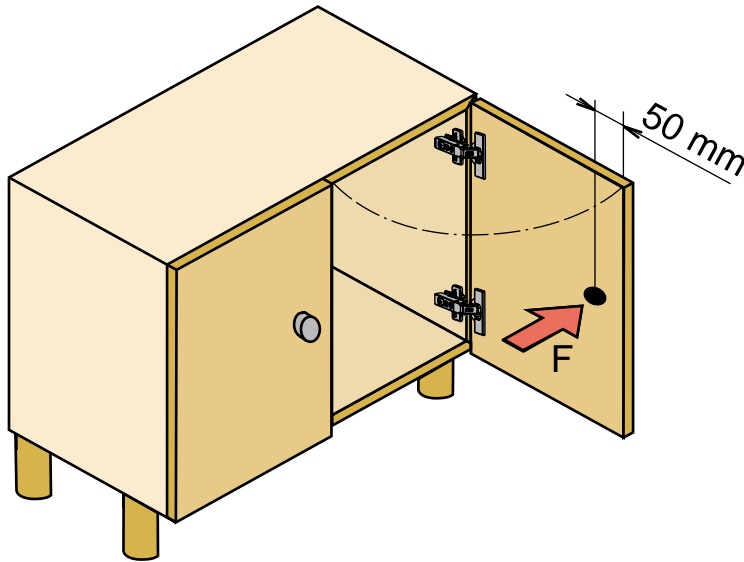

### Extension test

In this test, the door is opened beyond the specified opening angle with a defined pressure force **F**.

### Vertical test

In this test, the door is subjected to a large **additional force G** and then put through a specific number of opening and closing cycles.

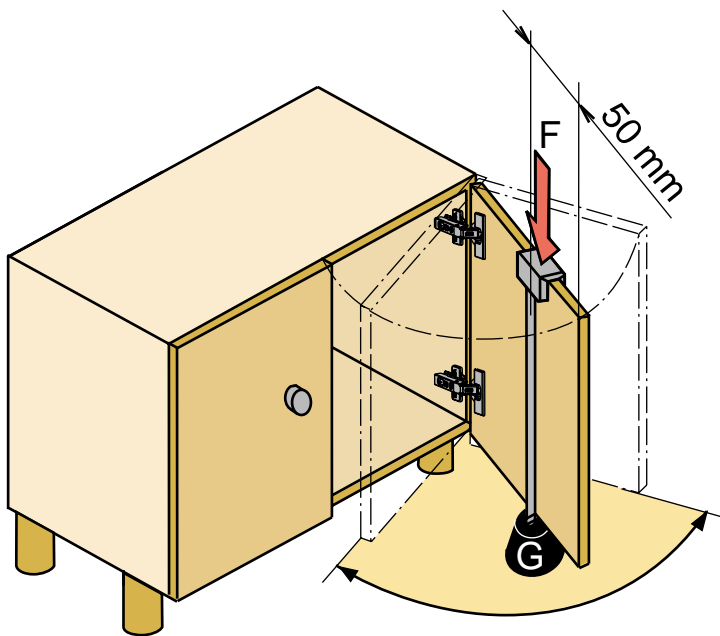
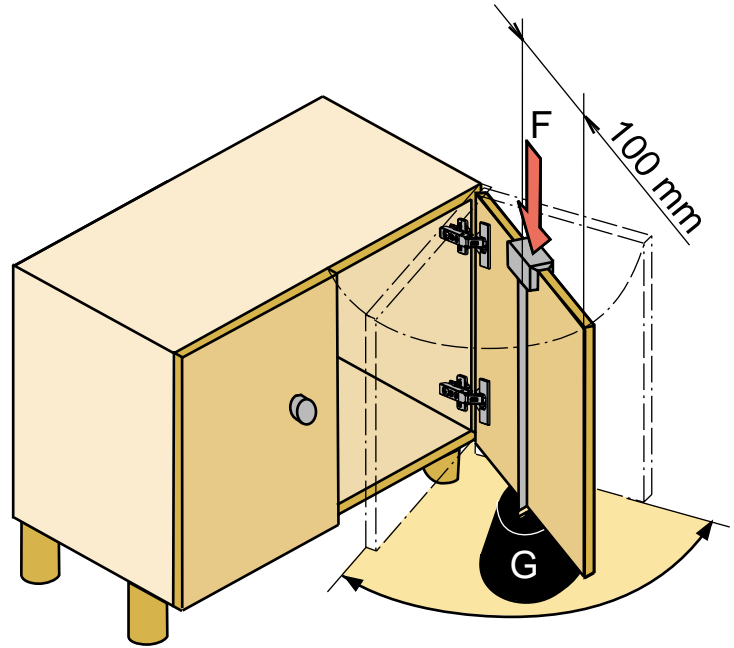

### Wear test

Loaded with a defined **force G**, the door must outlast a specific number of opening and closing cycles.

# Intermat and Ecomat

## Fast-assembly hinges ...



**Intermat Top *exclusive***  
Opening angle 110°

Pages 3.24 – 3.25



**Intermat 9943 / 9943 FIX**  
Opening angle 110°  
and aluminium frame profiles  
Pages 3.26 – 3.33



**Ecomat 9843 / 9843 FIX**  
Opening angle 110°

Pages 3.34 – 3.37



**Intermat 9944 / 9944 FIX**  
Opening angle 125°

Pages 3.38 – 3.41



**Intermat 9956 / 9956 FIX**  
Opening angle 120°-165°

Pages 3.42 – 3.45



**Intermat 9936 / 9936 FIX**  
for profile doors up to 32 mm  
Opening angle 95°  
Pages 3.46 – 3.50



**Intermat 9935**  
for profile doors up to 43 mm  
Opening angle 95°  
Pages 3.51 – 3.53



**Intermat 9936 W20 / 9936 W20 FIX**  
for cabinet face angle 20°  
Opening angle 95°  
Pages 3.54 – 3.57



**Intermat 9936 W30 / 9936 W30 FIX**  
for cabinet face angle 30°  
Opening angle 95°  
Pages 3.58 – 3.61



**Intermat 9936 W45 / 9936 W45 FIX**  
for cabinet face angle 45°  
Opening angle 95°  
Pages 3.62 – 3.67



**Intermat 9936 W90 / 9936 W90 FIX**  
for cabinets with blind panels 90°  
Opening angle 95°  
Pages 3.68 – 3.71



**Intermat 9944 W-30 / 9944 W-30 FIX**  
for negative cabinet angle -30°  
Opening angle 125°  
Pages 3.72 – 3.75

3

# the complete programme

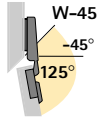

**Intermat 9944 W -45 / 9944 W -45 FIX**  
for negative cabinet angle -45°  
Opening angle 125°  
Pages 3.76 – 3.79

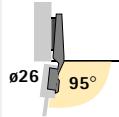

**Intermat 9924**  
for smaller doors/narrow frame doors  
Opening angle 95°  
and aluminium frame profiles  
Pages 3.80 – 3.83

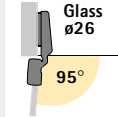

**Intermat 9904**  
for glass doors  
Opening angle 95°  
Pages 3.84 – 3.85

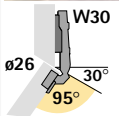

**Intermat 9924 W30**  
for smaller doors / narrow frame doors  
Cabinet face angle 30°  
Opening angle 95°  
Pages 3.86 – 3.87

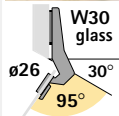

**Intermat 9904 W30**  
for glass doors with cabinet angle 30°  
Opening angle 95°  
Pages 3.88 – 3.89

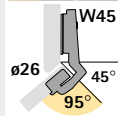

**Intermat 9924 W45**  
for smaller doors/narrow frame doors  
Cabinet face angle 45°  
Opening angle 95°  
Pages 3.90 – 3.91

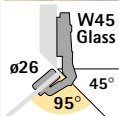

**Intermat 9904 W45**  
for glass doors with cabinet angle 45°  
Opening angle 95°  
Pages 3.92 – 3.93

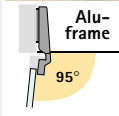

**Intermat 9936 Alu**  
for alu frame doors, opening angle 95°  
Pages 3.94 – 3.95  
**Sets Alu-frame doors** Pages 3.96 – 3.97  
Alu-frame profiles Pages 3.98 – 3.99

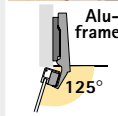
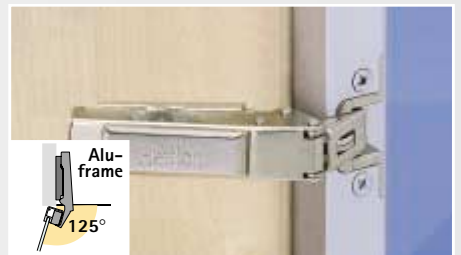

**Intermat 9944 Alu**  
for alu frame doors  
Opening angle 125°  
Pages 3.100 – 3.101

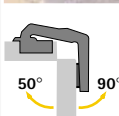
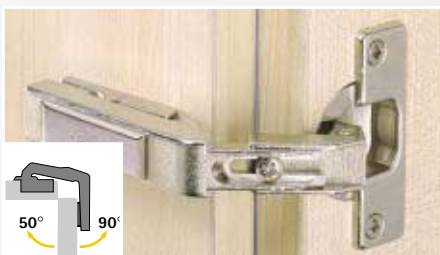

**Intermat 9930 / 9930 FIX**  
for corner cabinet folding doors  
Opening angle 50°/90°  
Pages 3.102 – 3.105

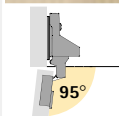

**Intermat 9945**  
for door overlay adjustment 12 mm  
Opening angle 95°  
Pages 3.106 – 3.107

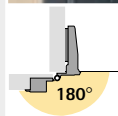

**Intermat Konsul 5**  
for rebated doors  
Opening angle 180°  
Pages 3.108 – 3.109

# Intermat Top *exclusiv* Fast-assembly hinge Opening angle 110°

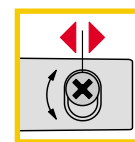
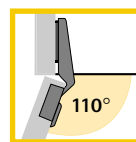

Concealed hinges, snap-on assembly, integrated door overlay and eccentric depth adjustment.

Opening angle 110°, cup diameter 35 mm

Intermat Top *exclusiv* hinges are snapped on to the mounting plate.

Depth adjustment infinitely adjustable via eccentric screw -0,5 mm/+3,5 mm. Height adjustment via mounting plate +2 mm/-2 mm, see pages 3.110 - 3.112.

Each Intermat Top *exclusiv* packing unit contains:

50 pcs. Intermat Top *exclusiv* hinges

50 pcs. **designer cover caps**, nickel-plated steel, with the logo Top *exclusiv*.

Cup fixing screw  $\varnothing$  3,5 x 13 mm nickel-plated, for cup T22

Order no. 048 296, VE 200

## Cup version

**Cup T22**  
Screw-on  
Die-cast zinc



**Cup T23**  
Press-in  
Die-cast zinc

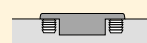

**Cup Flash**  
Fast-assembly  
Nickel-plated steel

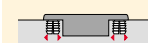

## Hinge version

Cranking 0 mm



## Mounting option

Full overlay

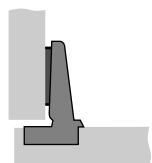

## Article/order number

Intermat Top *exclusiv*

● self-closing

Packaging unit 50 pcs

● Intermat  
Top *exclusiv* T22  
020 000

● Intermat  
Top *exclusiv* T23  
020 003

● Intermat  
Top *exclusiv* Flash  
020 006

## Door buffer Silent System



clip-on

048 044



screw-on

042 001

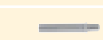

drill-in

048 047

Cranking 9,5 mm



Half overlay

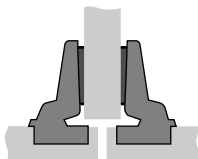

## Intermat Top *exclusiv*

● self-closing

Packaging unit 50 pcs

● Intermat  
Top *exclusiv* T22  
020 001

● Intermat  
Top *exclusiv* T23  
020 004

● Intermat  
Top *exclusiv* Flash  
020 007

## Door buffer Silent System



clip-on

048 045



screw-on

042 001



drill-in

048 047

Cranking 16 mm



Inset

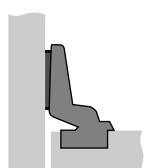

## Intermat Top *exclusiv*

● self-closing

Packaging unit 50 pcs

● Intermat  
Top *exclusiv* T22  
020 002

● Intermat  
Top *exclusiv* T23  
020 005

● Intermat  
Top *exclusiv* Flash  
020 008

## Door buffer Silent System



clip-on

048 046



screw-on

048 048

# Specification

## Hettich **Intermat Top** *exclusiv*

Snap-on assembly with eccentric depth adjustment

Opening angle 110°

| Cup distance<br>C mm  | Door thickness mm |     |     |     |     |     |     |     |     |     |     |     |     |
|---|-------------------|-----|-----|-----|-----|-----|-----|-----|-----|-----|-----|-----|-----|
|   | 16                | 17  | 18  | 19  | 20  | 21  | 22  | 23  | 24  | 25  | 26  | 27  | 28  |
| Minimum reveal per door – allow for in distance calculation |                   |     |     |     |     |     |     |     |     |     |     |     |     |
| Table entries apply to doors with 0 mm radius               |                   |     |     |     |     |     |     |     |     |     |     |     |     |
| 3   | 0,9               | 1,2 | 1,5 | 1,7 | 2,1 | 2,6 | 3,2 | 3,9 | 4,7 | 5,5 | 6,4 | 7,3 | 8,2 |
| 4   | 0,9               | 1,1 | 1,4 | 1,6 | 2,0 | 2,5 | 3,0 | 3,6 | 4,4 | 5,2 | 6,0 | 6,8 | 7,7 |
| 4,5   | 0,8               | 1,1 | 1,4 | 1,6 | 2,0 | 2,5 | 3,0 | 3,5 | 4,2 | 5,0 | 5,8 | 6,6 | 7,4 |
| 5   | 0,8               | 1,1 | 1,4 | 1,6 | 2,0 | 2,4 | 2,8 | 3,3 | 4,0 | 4,7 | 5,5 | 6,4 | 7,2 |
| 6   | 0,8               | 1,1 | 1,4 | 1,6 | 1,9 | 2,3 | 2,7 | 3,2 | 3,8 | 4,4 | 5,2 | 6,0 | 6,8 |

The minimum reveal is reduced for doors with radii: 1 mm radius: table entry – 0,4 mm  
3 mm radius: table entry – 1,2 mm

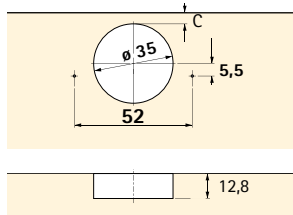

T22 hole dimensions

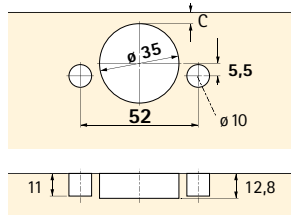

T23 / Flash hole dimensions

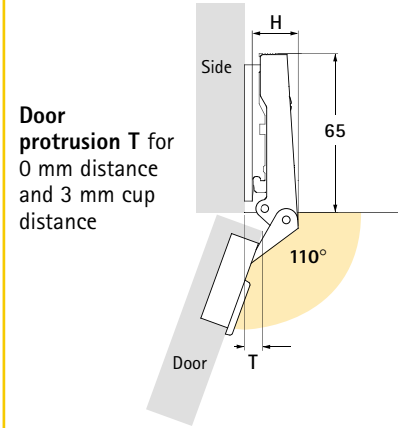

Door protrusion T for 0 mm distance and 3 mm cup distance

| Cranking mm | H mm | T mm |
|-------------|------|------|
| 0           | 19   | 7    |
| 9,5         | 28,5 | 16,5 |
| 16          | 35   | 23   |

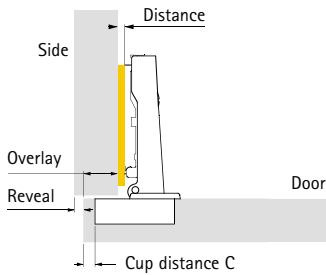

| Cup distance<br>C mm | Overlay mm |     |     |     |     |     |     |     |     |     |
|----------------------|------------|-----|-----|-----|-----|-----|-----|-----|-----|-----|
|                      | 10         | 11  | 12  | 13  | 14  | 15  | 16  | 17  | 18  | 19  |
| Distance D mm        |            |     |     |     |     |     |     |     |     |     |
| 3                    | 6,0        | 5,0 | 4,0 | 3,0 | 2,0 | 1,0 | 0,0 |     |     |     |
| 4                    | 7,0        | 6,0 | 5,0 | 4,0 | 3,0 | 2,0 | 1,0 | 0,0 |     |     |
| 4,5                  | 7,5        | 6,5 | 5,5 | 4,5 | 3,5 | 2,5 | 1,5 | 0,5 |     |     |
| 5                    | 8,0        | 7,0 | 6,0 | 5,0 | 4,0 | 3,0 | 2,0 | 1,0 | 0,0 |     |
| 6                    | 9,0        | 8,0 | 7,0 | 6,0 | 5,0 | 4,0 | 3,0 | 2,0 | 1,0 | 0,0 |

\* Overlay adjustment – 4 mm, + 0,5 mm

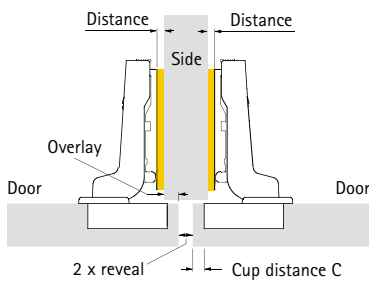

| Cup distance<br>C mm | Overlay mm |     |     |     |     |     |     |     |     |     |
|----------------------|------------|-----|-----|-----|-----|-----|-----|-----|-----|-----|
|                      | 0,5        | 1,5 | 2,5 | 3,5 | 4,5 | 5,5 | 6,5 | 7,5 | 8,5 | 9,5 |
| Distance D mm        |            |     |     |     |     |     |     |     |     |     |
| 3                    | 6,0        | 5,0 | 4,0 | 3,0 | 2,0 | 1,0 | 0,0 |     |     |     |
| 4                    | 7,0        | 6,0 | 5,0 | 4,0 | 3,0 | 2,0 | 1,0 | 0,0 |     |     |
| 4,5                  | 7,5        | 6,5 | 5,5 | 4,5 | 3,5 | 2,5 | 1,5 | 0,5 |     |     |
| 5                    | 8,0        | 7,0 | 6,0 | 5,0 | 4,0 | 3,0 | 2,0 | 1,0 | 0,0 |     |
| 6                    | 9,0        | 8,0 | 7,0 | 6,0 | 5,0 | 4,0 | 3,0 | 2,0 | 1,0 | 0,0 |

\* Overlay adjustment – 4 mm, + 0,5 mm

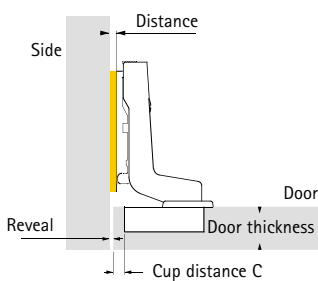

| Cup distance<br>C mm | Door thickness mm |     |     |     |     |     |     |     |     |     |     |     |     |
|----------------------|-------------------|-----|-----|-----|-----|-----|-----|-----|-----|-----|-----|-----|-----|
|                      | 16                | 17  | 18  | 19  | 20  | 21  | 22  | 23  | 24  | 25  | 26  | 27  | 28  |
| Distance D mm        |                   |     |     |     |     |     |     |     |     |     |     |     |     |
| 3                    | 0,9               | 1,2 | 1,5 | 1,7 | 2,1 | 2,6 | 3,2 | 3,9 | 4,7 | 5,5 | 6,4 | 7,3 | 8,2 |
| 4                    | 1,9               | 2,1 | 2,3 | 2,6 | 3,0 | 3,5 | 4,0 | 4,6 | 5,4 | 6,2 | 7,0 | 7,8 | 8,7 |
| 4,5                  | 2,3               | 2,6 | 2,9 | 3,1 | 3,5 | 4,0 | 4,5 | 5,0 | 5,7 | 6,5 | 7,3 | 8,1 | 8,9 |
| 5                    | 2,8               | 3,1 | 3,4 | 3,6 | 4,0 | 4,4 | 4,8 | 5,3 | 6,0 | 6,7 | 7,5 | 8,4 | 9,2 |
| 6                    | 3,8               | 4,1 | 4,4 | 4,6 | 4,9 | 5,3 | 5,7 | 6,2 | 6,8 | 7,4 | 8,2 | 9,0 | 9,8 |

\*Reveal adjustment + 4 mm, – 0,5 mm

# Intermat 9943

## Fast-assembly hinge

### Opening angle 110°

Door thickness from 15 mm

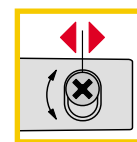
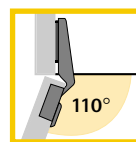

**Concealed hinge with snap-on assembly, integrated door overlay and eccentric depth adjustment.**

Opening angle 110°, cup diameter 35 mm

Small hole depth for door thickness 15 mm or larger.

Interimat 9943 hinges are snapped on to the mounting plate.

Depth adjustment via eccentric screw -0,5 mm/+3,5 mm.

Height adjustment via mounting plate +2 mm/-2 mm, see page 3.110 - 3.112.

Cup fixing screw  $\varnothing$  3,5 x 13 mm nickel-plated, for cup T 42

Order no. 048 296, PU 200

#### Cup version

##### Cup T42

Screw-on  
Nickel-plated  
steel

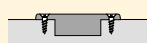

##### Cup T43

Press-in  
Nickel-plated  
steel

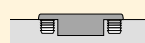

##### Cup TB43

Press-in  
Nickel-plated  
steel

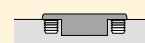

##### Cup Flash

Fast-assembly  
Nickel-plated  
steel

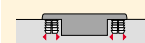

#### Hinge version

Cranking 0 mm



#### Mounting option

Full overlay

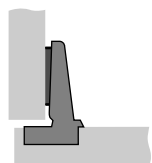

#### Article/order number

##### Interimat 9943

- self-closing

Packaging unit 50 pcs

● 9943-  
T42  
048 049

● 9943-  
T43  
048 053

● 9943-  
TB 43  
048 056

● 9943-  
Flash  
048 059

##### Door buffer Silent System

|  |          |         |
|--|----------|---------|
|  | clip-on  | 048 044 |
|  | screw-on | 042 001 |
|  | drill-in | 048 047 |

Cranking 9,5 mm



Half overlay

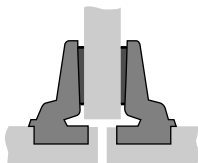

##### Interimat 9943

- self-closing

Packaging unit 50 pcs

● 9943-  
T42  
048 051

● 9943-  
T43  
048 054

● 9943-  
TB 43  
048 057

● 9943-  
Flash  
048 061

##### Door buffer Silent System

|  |          |         |
|--|----------|---------|
|  | clip-on  | 048 045 |
|  | screw-on | 042 001 |
|  | drill-in | 048 047 |

Cranking 16 mm



Inset

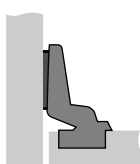

##### Interimat 9943

- self-closing

Packaging unit 50 pcs

● 9943-  
T42  
048 052

● 9943-  
T43  
048 055

● 9943-  
TB 43  
048 058

● 9943-  
Flash  
048 062

##### Door buffer Silent System

|  |          |         |
|--|----------|---------|
|  | clip-on  | 048 046 |
|  | screw-on | 048 048 |

## Specification

Hettich Intermat 9943

Snap-on assembly

Eccentric depth adjustment

for door thickness from 15 mm

Opening angle 110°

## Cover cap for Intermat hinges

Nickel-plated steel

Order no. **013 300**

Black plastic

Order no. **048 043**

PU = 50 pcs



| Cup distance<br>C mm   | Door thickness mm |     |     |     |     |     |     |     |     |     |     |
|--|-------------------|-----|-----|-----|-----|-----|-----|-----|-----|-----|-----|
|  | 15                | 16  | 17  | 18  | 19  | 20  | 21  | 22  | 23  | 24  | 25  |
| <b>Minimum reveal per door – allow for in distance calculation</b> |                   |     |     |     |     |     |     |     |     |     |     |
| Table entries apply to doors with 0 mm radius                      |                   |     |     |     |     |     |     |     |     |     |     |
| 3  | 0,5               | 0,6 | 0,8 | 1,1 | 1,5 | 1,9 | 2,4 | 3,1 | 4,0 | 4,8 | 5,8 |
| 4  | 0,4               | 0,5 | 0,7 | 1,0 | 1,4 | 1,8 | 2,3 | 2,8 | 3,5 | 4,3 | 5,3 |
| 4,5  | 0,4               | 0,5 | 0,7 | 1,0 | 1,4 | 1,8 | 2,3 | 2,8 | 3,5 | 4,2 | 5,1 |
| 5  | 0,4               | 0,5 | 0,7 | 1,0 | 1,4 | 1,8 | 2,3 | 2,8 | 3,5 | 4,1 | 4,8 |
| 6  | 0,4               | 0,5 | 0,7 | 1,0 | 1,4 | 1,7 | 2,3 | 2,7 | 3,3 | 3,8 | 4,4 |

The minimum reveal is reduced for doors with radii: 1 mm radius: table entry – 0,4 mm  
3 mm radius: table entry – 1,2 mm

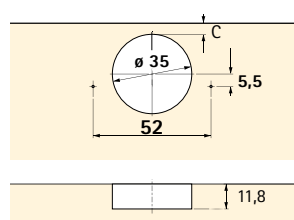

T42 hole dimensions

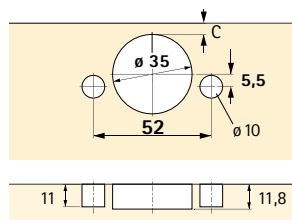

T43 / Flash hole dimensions

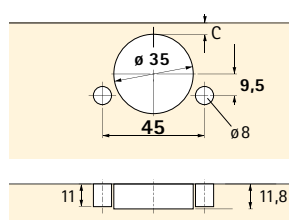

TB 43 hole dimensions

Door  
protrusion T for  
0 mm distance  
and 3 mm cup  
distance

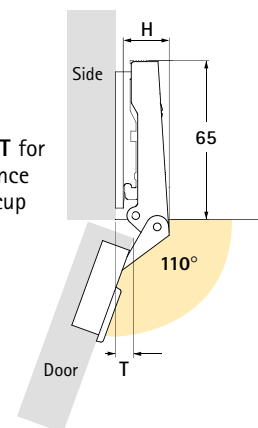

| Cranking<br>mm | H<br>mm | T<br>mm |
|----------------|---------|---------|
| 0              | 18,5    | 7       |
| 9,5            | 28      | 16,5    |
| 16             | 34,5    | 23      |

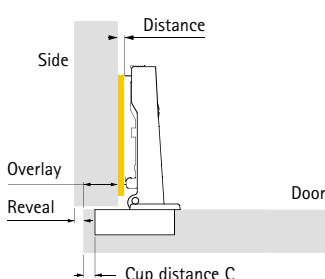

| Cup distance<br>C mm | Overlay mm |     |     |     |     |     |     |     |     |     |
|----------------------|------------|-----|-----|-----|-----|-----|-----|-----|-----|-----|
|                      | 10         | 11  | 12  | 13  | 14  | 15  | 16  | 17  | 18  | 19  |
| <b>Distance D mm</b> |            |     |     |     |     |     |     |     |     |     |
| 3                    | 6,0        | 5,0 | 4,0 | 3,0 | 2,0 | 1,0 | 0,0 |     |     |     |
| 4                    | 7,0        | 6,0 | 5,0 | 4,0 | 3,0 | 2,0 | 1,0 | 0,0 |     |     |
| 4,5                  | 7,5        | 6,5 | 5,5 | 4,5 | 3,5 | 2,5 | 1,5 | 0,5 |     |     |
| 5                    | 8,0        | 7,0 | 6,0 | 5,0 | 4,0 | 3,0 | 2,0 | 1,0 | 0,0 |     |
| 6                    | 9,0        | 8,0 | 7,0 | 6,0 | 5,0 | 4,0 | 3,0 | 2,0 | 1,0 | 0,0 |

\* Overlay adjustment – 4 mm, + 0,5 mm

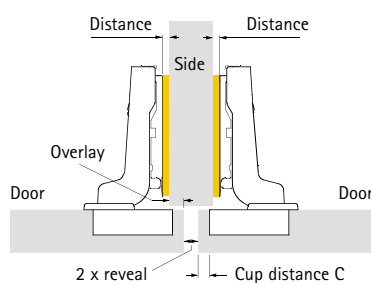

| Cup distance<br>C mm | Overlay mm |     |     |     |     |     |     |     |     |     |
|----------------------|------------|-----|-----|-----|-----|-----|-----|-----|-----|-----|
|                      | 0,5        | 1,5 | 2,5 | 3,5 | 4,5 | 5,5 | 6,5 | 7,5 | 8,5 | 9,5 |
| <b>Distance D mm</b> |            |     |     |     |     |     |     |     |     |     |
| 3                    | 6,0        | 5,0 | 4,0 | 3,0 | 2,0 | 1,0 | 0,0 |     |     |     |
| 4                    | 7,0        | 6,0 | 5,0 | 4,0 | 3,0 | 2,0 | 1,0 | 0,0 |     |     |
| 4,5                  | 7,5        | 6,5 | 5,5 | 4,5 | 3,5 | 2,5 | 1,5 | 0,5 |     |     |
| 5                    | 8,0        | 7,0 | 6,0 | 5,0 | 4,0 | 3,0 | 2,0 | 1,0 | 0,0 |     |
| 6                    | 9,0        | 8,0 | 7,0 | 6,0 | 5,0 | 4,0 | 3,0 | 2,0 | 1,0 | 0,0 |

\* Overlay adjustment – 4 mm, + 0,5 mm

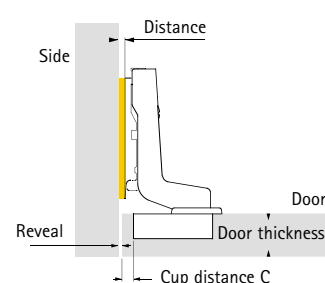

| Cup distance<br>C mm | Door thickness mm |     |     |     |     |     |     |     |     |     |     |     |     |
|----------------------|-------------------|-----|-----|-----|-----|-----|-----|-----|-----|-----|-----|-----|-----|
|                      | 16                | 17  | 18  | 19  | 20  | 21  | 22  | 23  | 24  | 25  | 26  | 27  | 28  |
| <b>Distance D mm</b> |                   |     |     |     |     |     |     |     |     |     |     |     |     |
| 3                    | 0,6               | 0,8 | 1,1 | 1,0 | 1,9 | 2,4 | 3,1 | 4,0 | 4,8 | 5,8 | 6,4 | 7,3 | 8,2 |
| 4                    | 1,5               | 1,7 | 2,0 | 2,4 | 2,8 | 3,3 | 3,8 | 4,5 | 5,3 | 6,3 | 7,0 | 7,8 | 8,7 |
| 4,5                  | 2,0               | 2,2 | 2,5 | 2,9 | 3,3 | 3,8 | 4,3 | 5,0 | 5,7 | 6,5 | 7,2 | 7,9 | 8,7 |
| 5                    | 2,5               | 2,7 | 3,0 | 3,4 | 3,8 | 4,3 | 4,8 | 5,5 | 6,1 | 6,8 | 7,5 | 8,4 | 9,2 |
| 6                    | 3,5               | 3,7 | 4,0 | 4,4 | 4,7 | 5,3 | 5,7 | 6,3 | 6,8 | 7,4 | 8,2 | 9,0 | 9,8 |

\* Reveal adjustment + 4 mm, – 0,5 mm

# Aluminium frame profile Width 55 mm, curved for Intermat 9943 T42

Can be made up to custom dimensions or ready-made up



This profile can be customised to size by the customer.

- Silver anodised surface
- Usable with 4 and 5 mm glass thickness
- Safe installation with fixing angles and screws

Cross-section

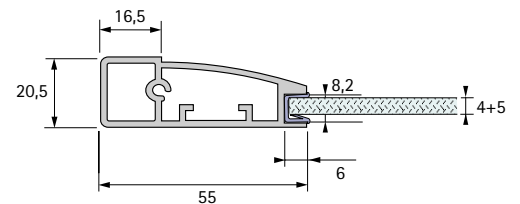

Angle set

contains:  
4 fixing angles  
8 fixing screws



Aluminium frame profile  
width 55 mm, curved  
silver anodised



Sealing strip  
for glass thickness 4 and 5 mm  
plastic, transparent



| Length  | Order no. | PU |
|---------|-----------|----|
| 6000 mm | 013 430   | 4  |
| 3000 mm | 020 035   | 4  |

| Length  | Order no. | PU |
|---------|-----------|----|
| 3500 mm | 075 620   | 1  |

| Article   | Order no. | PU    |
|-----------|-----------|-------|
| Angle set | 013 684   | 1 set |

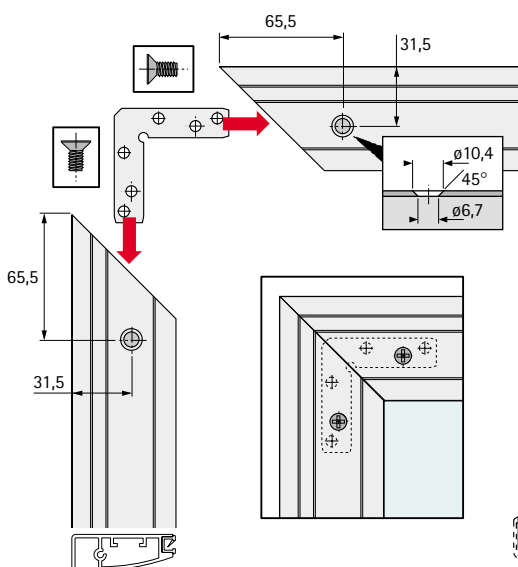

Hinge fastened with  
special cup screw  
Ø 3,5 x 9,5  
see page 3.29

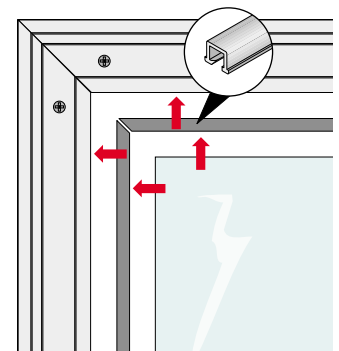
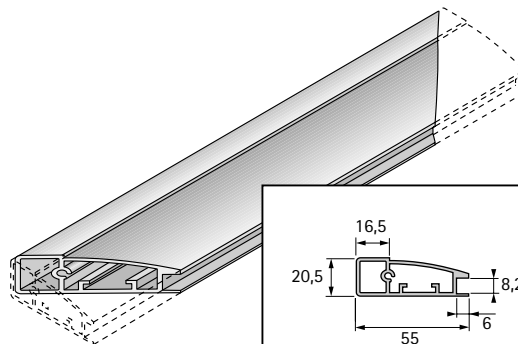

Glass cutting dimension =  
door width/height - 102 mm

# Fax order to your specialist retailer

Simply fill in the fax form to receive a set of aluminium frame profiles fully customised to your dimensions, width 55 mm, curved

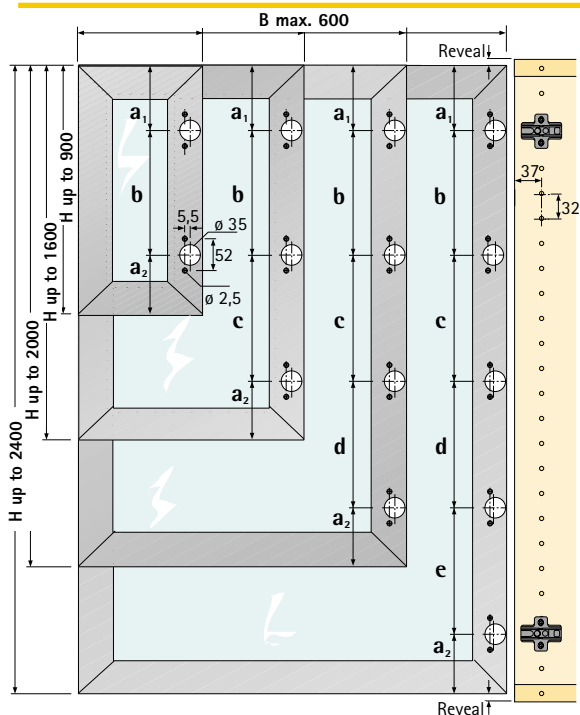

### Aluminium frame profile set, width 55 mm, curved made to measure

contains: 4 aluminium frame profiles, silver anodised  
4 sealing profiles for 4 mm and 5 mm gauge glass

| Order no. | PU    | Door perimeter mm | Number of doors |
|-----------|-------|-------------------|-----------------|
| 041 283   | 1 set |                   |                 |

### Fabrication for an aluminium frame, width 55 mm, curved

contains: mitre cuts, including cutting to length  
drill holes for mitre joint  
4 connecting angles  
8 countersunk screws

| Order no. | PU | Number of doors |
|-----------|----|-----------------|
| 041 287   | 1  |                 |

**Attention:** Use a separate order sheet for each frame size/door size.  
Please specify all measurements in mm!

|                                  | up to 900 | up to 1600 | up to 2000 | up to 2400 |
|----------------------------------|-----------|------------|------------|------------|
| <b>H</b>                         |           |            |            |            |
| <b>B</b><br>max. 600             |           |            |            |            |
| <b>a<sub>1</sub></b><br>min. 115 |           |            |            |            |
| <b>b</b>                         |           |            |            |            |
| <b>c</b>                         |           |            |            |            |
| <b>d</b>                         |           |            |            |            |
| <b>e</b>                         |           |            |            |            |
| <b>a<sub>2</sub></b><br>min. 115 |           |            |            |            |
| left<br>Number of doors          |           |            |            |            |
| right<br>Number of doors         |           |            |            |            |

### Fabrication for hinged doors

contains: 1 hinge drill hole  $\varnothing$  35 mm

| Order no. | PU | Order quantity* |
|-----------|----|-----------------|
| 041 292   | 1  |                 |

\* Number of hinge slots

Intermat 9943,  
opening angle 110°,  
cup diameter  
35 mm, T42

| Version  | Order no. | Stock    | Order quantity |
|--|-----------|----------|----------------|
| Cranking 0 mm, full overlay                      | 048 049   | Retailer |                |
| Cranking 9,5 mm, half overlay                    | 048 051   | Retailer |                |
| Cranking 16 mm, inset                            | 048 052   | Retailer |                |
| Special cup fixing screw $\varnothing$ 3,5 x 9,5 | 041 296   | Retailer |                |

Mounting plates and cover caps for Intermat hinges must be ordered separately

|                         |                              |
|-------------------------|------------------------------|
| Joiner/interior fitter: | Date: _____ Signature: _____ |
|-------------------------|------------------------------|

# Aluminium frame profile

## Width 55 mm, straight

### for Intermat 9943 T42

Can be made up to custom dimensions or ready-made up



This profile can be customised to size by the customer.

- Silver anodised surface
- Usable with 4 mm glass thickness
- Can be cut to individually required lengths
- Safe installation with fixing angles and screws

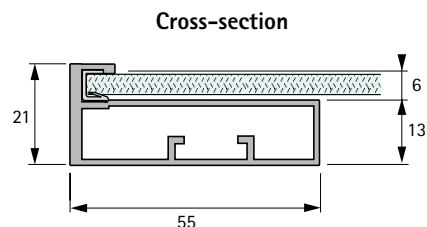

3

#### Aluminium frame profile set, width 55 mm, straight

contains:

- 1 aluminium frame profile, silver anodised
- 1 sealing strip for glass thickness 4 mm plastic, transparent



#### Angle set

contains:

- 4 fixing angles
- 8 fixing screws



| Length mm | Order no. | PU    |
|-----------|-----------|-------|
| 3000      | 020 401   | 1 set |

| Article   | Order no. | PU    |
|-----------|-----------|-------|
| Angle set | 013 684   | 1 set |

Glass cutting dimension = door width/height - 7 mm

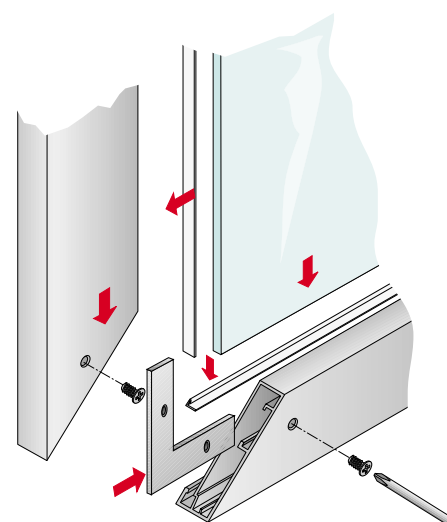
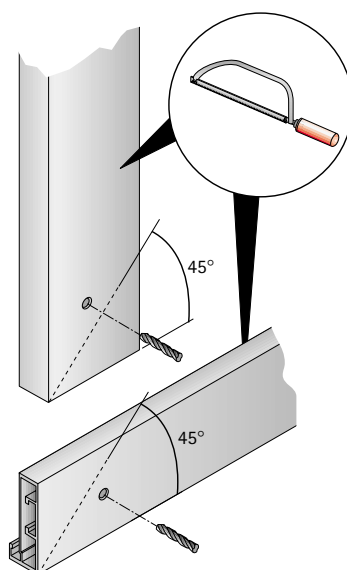
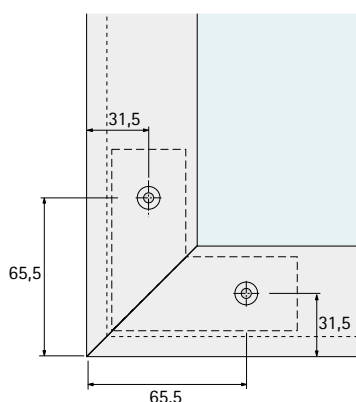

Hinge fastened with special cup screw  $\varnothing 3,5 \times 9,5$  see page 3.31

# Fax order to your specialist retailer

Simply fill in the fax form to receive a set of aluminium frame profiles fully customised to your dimensions, width 55 mm, straight

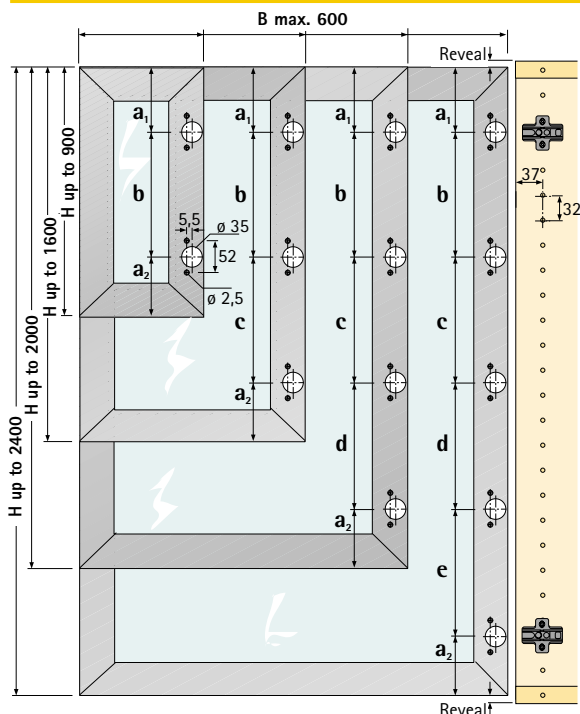

## Aluminium frame profile set, width 55 mm, straight made to measure

contains: 4 aluminium frame profiles, silver anodised  
4 sealing profiles for 4 mm gauge glass

| Order no. | PU    | Door perimeter mm | Number of doors |
|-----------|-------|-------------------|-----------------|
| 041 284   | 1 set |                   |                 |

## Fabrication for an aluminium frame, width 55 mm, straight

contains: mitre cuts, including cutting to length  
drill holes for mitre joint  
4 connecting angles  
8 countersunk screws

| Order no. | PU | Number of doors |
|-----------|----|-----------------|
| 041 288   | 1  |                 |

**Attention:** Use a separate order sheet for each frame size/door size.  
Please specify all measurements in mm!

|                                  | up to 900 | up to 1600 | up to 2000 | up to 2400 |
|----------------------------------|-----------|------------|------------|------------|
| <b>H</b>                         |           |            |            |            |
| <b>B</b><br>max. 600             |           |            |            |            |
| <b>a<sub>1</sub></b><br>min. 115 |           |            |            |            |
| <b>b</b>                         |           |            |            |            |
| <b>c</b>                         |           |            |            |            |
| <b>d</b>                         |           |            |            |            |
| <b>e</b>                         |           |            |            |            |
| <b>a<sub>2</sub></b><br>min. 115 |           |            |            |            |
| left<br>Number of doors          |           |            |            |            |
| right<br>Number of doors         |           |            |            |            |

## Fabrication for hinged doors

contains: 1 hinge drill hole  $\varnothing$  35 mm

| Order no. | PU | Order quantity* |
|-----------|----|-----------------|
| 041 292   | 1  |                 |

\* Number of hinge slots

**Intermat 9943,**  
opening angle 110°,  
cup diameter  
35 mm, T42

| Version  | Order no. | Stock    | Order quantity |
|--|-----------|----------|----------------|
| Cranking 0 mm, full overlay                      | 048 049   | Retailer |                |
| Cranking 9,5 mm, half overlay                    | 048 051   | Retailer |                |
| Cranking 16 mm, inset                            | 048 052   | Retailer |                |
| Special cup fixing screw $\varnothing$ 3,5 x 9,5 | 041 296   | Retailer |                |

Mounting plates and cover caps for Intermat hinges must be ordered separately

|                         |                  |
|-------------------------|------------------|
| Joiner/interior fitter: |                  |
|                         |                  |
| Date: _____             | Signature: _____ |

# Intermat 9943 FIX

## Toolless fast-assembly

### Opening angle 110°

Door thickness from 15 mm

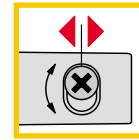
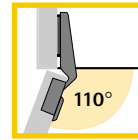
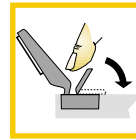

**Concealed hinge with snap-on assembly plus toolless cup assembly, integrated door overlay and eccentric depth adjustment.**

Opening angle 110°, cup diameter 35 mm

Small hole depth for door thickness 15 mm or larger.

Intermat 9943 FIX hinges are snapped onto the mounting plate and also feature toolless cup assembly.

Depth adjustment via eccentric screw -0,5 mm/+3,5 mm.

Height adjustment via mounting plate +2 mm/-2 mm, see pages 3.110 - 3.112.

#### Cup version

**Cup T FIX**  
Toolless  
Nickel-plated steel

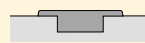

**Cup TH FIX**  
Toolless  
with pegs  
Nickel-plated steel

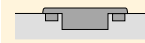

**Cup TB FIX**  
Toolless  
with pegs  
Nickel-plated steel

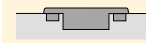

#### Hinge version

#### Mounting option

#### Article/order number

##### Intermat 9943 FIX

- self-closing

Packaging unit 50 pcs

● 9943-T FIX  
048 063

● 9943-TH FIX  
048 066

● 9943-TB FIX  
048 071

##### Door buffer Silent System

clip-on

048 044

screw-on

042 001

drill-in

048 047



#### Full overlay

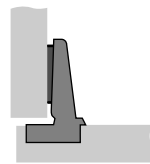

#### Half overlay

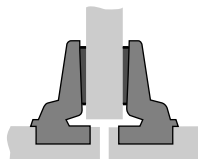

##### Intermat 9943 FIX

- self-closing

Packaging unit 50 pcs

● 9943-T FIX  
048 064

● 9943-TH FIX  
048 068

● 9943-TB FIX  
048 072

##### Door buffer Silent System

clip-on

048 045

screw-on

042 001

drill-in

048 047



#### Inset

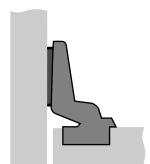

##### Intermat 9943 FIX

- self-closing

Packaging unit 50 pcs

● 9943-T FIX  
048 065

● 9943-TH FIX  
048 069

● 9943-TB FIX  
048 073

##### Door buffer Silent System

clip-on

048 046

screw-on

048 048

## Specification

Hettich Intermat 9943 Fix  
 Snap-on assembly plus toolless cup assembly  
 Eccentric depth adjustment  
 for door thickness from 15 mm  
 Opening angle 110°

### Cover cap for Intermat hinges

Nickel-plated steel  
**Order no. 013 300**  
 Black plastic  
**Order no. 048 043**  
 PU = 50 pcs

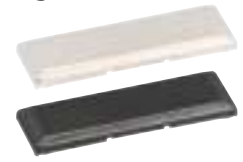

| Cup distance<br>C mm   | Door thickness mm |     |     |     |     |     |     |     |     |     |     |
|--|-------------------|-----|-----|-----|-----|-----|-----|-----|-----|-----|-----|
|  | 15                | 16  | 17  | 18  | 19  | 20  | 21  | 22  | 23  | 24  | 25  |
| <b>Minimum reveal per door – allow for in distance calculation</b> |                   |     |     |     |     |     |     |     |     |     |     |
| Table entries apply to doors with 0 mm radius                      |                   |     |     |     |     |     |     |     |     |     |     |
| 3  | 0,5               | 0,6 | 0,8 | 1,1 | 1,5 | 1,9 | 2,4 | 3,1 | 4,0 | 4,8 | 5,8 |
| 4  | 0,4               | 0,5 | 0,7 | 1,0 | 1,4 | 1,8 | 2,3 | 2,8 | 3,5 | 4,3 | 5,3 |
| 4,5  | 0,4               | 0,5 | 0,7 | 1,0 | 1,4 | 1,8 | 2,3 | 2,8 | 3,5 | 4,2 | 5,1 |
| 5  | 0,4               | 0,5 | 0,7 | 1,0 | 1,4 | 1,8 | 2,3 | 2,8 | 3,5 | 4,1 | 4,8 |
| 6  | 0,4               | 0,5 | 0,7 | 1,0 | 1,4 | 1,7 | 2,3 | 2,7 | 3,3 | 3,8 | 4,4 |

The minimum reveal is reduced for doors with radii:  
 1 mm radius: table entry – 0,4 mm  
 3 mm radius: table entry – 1,2 mm

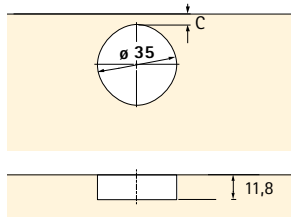

T FIX hole dimensions

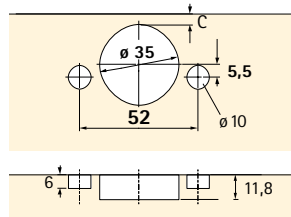

TH FIX hole dimensions

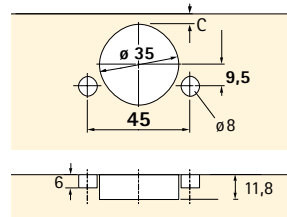

TB FIX hole dimensions

Door  
 protrusion T for  
 0 mm distance  
 and 3 mm cup  
 distance

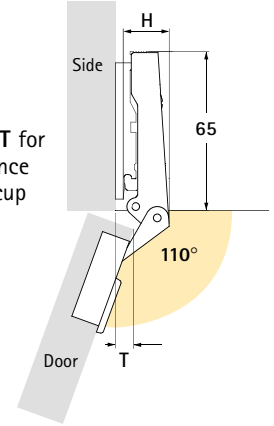

| Cranking<br>mm | H<br>mm | T<br>mm |
|----------------|---------|---------|
| 0              | 18,5    | 7       |
| 9,5            | 28      | 16,5    |
| 16             | 34,5    | 23      |

3

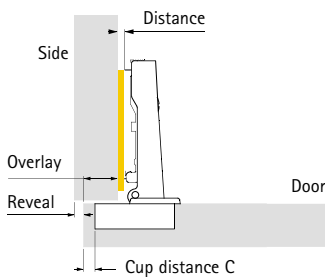

| Cup distance<br>C mm | Overlay mm |     |     |     |     |     |     |     |     |     |
|----------------------|------------|-----|-----|-----|-----|-----|-----|-----|-----|-----|
|                      | 10         | 11  | 12  | 13  | 14  | 15  | 16  | 17  | 18  | 19  |
| <b>Distance D mm</b> |            |     |     |     |     |     |     |     |     |     |
| 3                    | 6,0        | 5,0 | 4,0 | 3,0 | 2,0 | 1,0 | 0,0 |     |     |     |
| 4                    | 7,0        | 6,0 | 5,0 | 4,0 | 3,0 | 2,0 | 1,0 | 0,0 |     |     |
| 4,5                  | 7,5        | 6,5 | 5,5 | 4,5 | 3,5 | 2,5 | 1,5 | 0,5 |     |     |
| 5                    | 8,0        | 7,0 | 6,0 | 5,0 | 4,0 | 3,0 | 2,0 | 1,0 | 0,0 |     |
| 6                    | 9,0        | 8,0 | 7,0 | 6,0 | 5,0 | 4,0 | 3,0 | 2,0 | 1,0 | 0,0 |

\* Overlay adjustment – 4 mm, + 0,5 mm

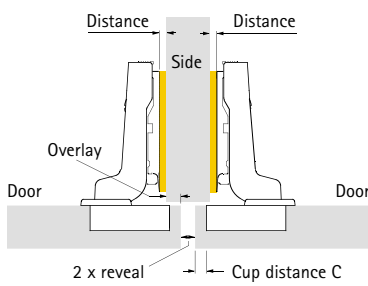

| Cup distance<br>C mm | Overlay mm |     |     |     |     |     |     |     |     |     |
|----------------------|------------|-----|-----|-----|-----|-----|-----|-----|-----|-----|
|                      | 0,5        | 1,5 | 2,5 | 3,5 | 4,5 | 5,5 | 6,5 | 7,5 | 8,5 | 9,5 |
| <b>Distance D mm</b> |            |     |     |     |     |     |     |     |     |     |
| 3                    | 6,0        | 5,0 | 4,0 | 3,0 | 2,0 | 1,0 | 0,0 |     |     |     |
| 4                    | 7,0        | 6,0 | 5,0 | 4,0 | 3,0 | 2,0 | 1,0 | 0,0 |     |     |
| 4,5                  | 7,5        | 6,5 | 5,5 | 4,5 | 3,5 | 2,5 | 1,5 | 0,5 |     |     |
| 5                    | 8,0        | 7,0 | 6,0 | 5,0 | 4,0 | 3,0 | 2,0 | 1,0 | 0,0 |     |
| 6                    | 9,0        | 8,0 | 7,0 | 6,0 | 5,0 | 4,0 | 3,0 | 2,0 | 1,0 | 0,0 |

\* Overlay adjustment – 4 mm, + 0,5 mm

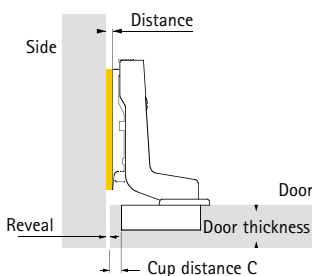

| Cup distance<br>C mm | Door thickness mm |     |     |     |     |     |     |     |     |     |     |     |     |
|----------------------|-------------------|-----|-----|-----|-----|-----|-----|-----|-----|-----|-----|-----|-----|
|                      | 16                | 17  | 18  | 19  | 20  | 21  | 22  | 23  | 24  | 25  | 26  | 27  | 28  |
| <b>Distanz D mm</b>  |                   |     |     |     |     |     |     |     |     |     |     |     |     |
| 3                    | 0,6               | 0,8 | 1,1 | 1,0 | 1,9 | 2,4 | 3,1 | 4,0 | 4,8 | 5,8 | 6,4 | 7,3 | 8,2 |
| 4                    | 1,5               | 1,7 | 2,0 | 2,4 | 2,8 | 3,3 | 3,8 | 4,5 | 5,3 | 6,3 | 7,0 | 7,8 | 8,7 |
| 4,5                  | 2,0               | 2,2 | 2,5 | 2,9 | 3,3 | 3,8 | 4,3 | 5,0 | 5,7 | 6,5 | 7,2 | 7,9 | 8,7 |
| 5                    | 2,5               | 2,7 | 3,0 | 3,4 | 3,8 | 4,3 | 4,8 | 5,5 | 6,1 | 6,8 | 7,5 | 8,4 | 9,2 |
| 6                    | 3,5               | 3,7 | 4,0 | 4,4 | 4,7 | 5,3 | 5,7 | 6,3 | 6,8 | 7,4 | 8,2 | 9,0 | 9,8 |

\* Reveal adjustment + 4 mm, – 0,5 mm

# Ecomat 9843

## Fast-assembly hinge

### Opening angle 110°

Door thickness from 15 mm

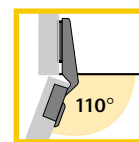

**Concealed hinges, snap-on assembly, integrated door overlay and depth adjustment.**

Opening angle 110°, cup diameter 35 mm

Small hole depth for door thickness 15 mm or larger.

Ecomat 9843 hinges are snapped onto the mounting plate.

Depth adjustment +2 mm/-2 mm

Height adjustment via mounting plate +2 mm/-2 mm, see pages 3.110 - 3.112.

Cup fixing screw  $\varnothing$  3,5 x 13 mm nickel-plated, for cup T 42

Order no. 048 296, PU 200

#### Cup version

##### Cup T 42

Screw-on  
Nickel-plated  
steel

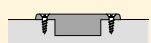

##### Cup T 43

Press-in  
Nickel-plated  
steel



##### Cup TB 43

Press-in  
Nickel-plated  
steel

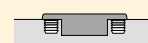

##### Flash cup

Fast-assembly  
Nickel-plated  
steel



#### Hinge version

#### Mounting option

#### Article/order number

##### Ecomat 9843

- self-closing

Packaging unit 50 pcs

● 9843-T42  
079 258

● 9843-T43  
079 261

● 9843-TB 43  
079 042

● 9843-Flash  
070 018

##### Door buffer Silent System

|  |          |         |
|--|----------|---------|
|  | clip-on  | 045 337 |
|  | screw-on | 042 001 |
|  | drill-in | 048 047 |



#### Full overlay

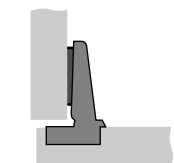

#### Half overlay

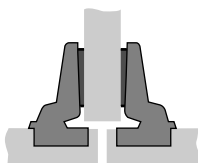

##### Ecomat 9843

- self-closing

Packaging unit 50 pcs

● 9843-T42  
079 259

● 9843-T43  
079 262

● 9843-TB 43  
079 043

● 9843-Flash  
070 019

##### Door buffer Silent System

|  |          |         |
|--|----------|---------|
|  | clip-on  | 045 338 |
|  | screw-on | 042 001 |
|  | drill-in | 048 047 |



#### Inset

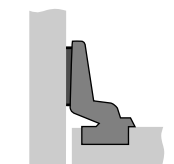

##### Ecomat 9843

- self-closing

Packaging unit 50 pcs

● 9843-T42  
079 260

● 9843-T43  
079 263

● 9843-TB 43  
079 044

● 9843-Flash  
070 020

##### Door buffer Silent System

|  |          |         |
|--|----------|---------|
|  | clip-on  | 045 339 |
|  | screw-on | 048 048 |

## Specification

Hettich Ecomat 9843

Snap-on assembly

Integrated overlay and depth adjustment  
for door thickness from 15 mm

Opening angle 110°

## Cover cap for Ecomat hinges

Nickel-plated steel

Order no. **079 790**

PU = 50 pcs



| Cup distance<br>C mm   | Door thickness mm |     |     |     |     |     |     |     |     |     |     |
|--|-------------------|-----|-----|-----|-----|-----|-----|-----|-----|-----|-----|
|  | 15                | 16  | 17  | 18  | 19  | 20  | 21  | 22  | 23  | 24  | 25  |
| <b>Minimum reveal per door – allow for in distance calculation</b> |                   |     |     |     |     |     |     |     |     |     |     |
| Table entries apply to doors with 0 mm radius                      |                   |     |     |     |     |     |     |     |     |     |     |
| 3  | 0,5               | 0,6 | 0,8 | 1,1 | 1,5 | 1,9 | 2,4 | 3,1 | 4,0 | 4,8 | 5,8 |
| 4  | 0,4               | 0,5 | 0,7 | 1,0 | 1,4 | 1,8 | 2,3 | 2,8 | 3,5 | 4,3 | 5,3 |
| 4,5  | 0,4               | 0,5 | 0,7 | 1,0 | 1,4 | 1,8 | 2,3 | 2,8 | 3,5 | 4,2 | 5,1 |
| 5  | 0,4               | 0,5 | 0,7 | 1,0 | 1,4 | 1,8 | 2,3 | 2,8 | 3,5 | 4,1 | 4,8 |
| 6  | 0,4               | 0,5 | 0,7 | 1,0 | 1,4 | 1,7 | 2,3 | 2,7 | 3,3 | 3,8 | 4,4 |

The minimum reveal is reduced for doors with radii: 1 mm radius: table entry – 0,4 mm  
3 mm radius: table entry – 1,2 mm

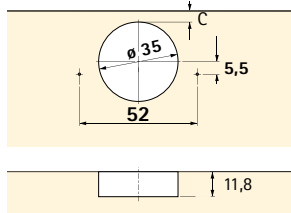

T42 hole dimensions

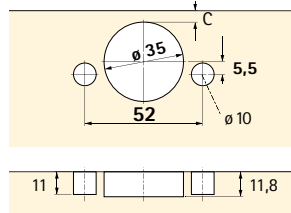

T43 / Flash hole dimensions

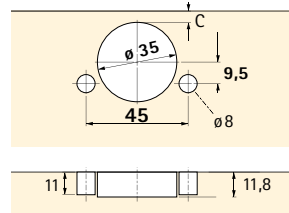

TB43 hole dimensions

Door  
protrusion T for  
0 mm distance  
and 3 mm cup  
distance

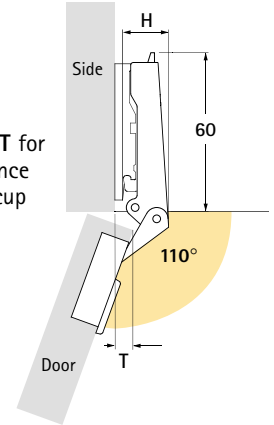

| Cranking<br>mm | H<br>mm | T<br>mm |
|----------------|---------|---------|
| 0              | 18,5    | 7       |
| 9,5            | 28      | 16,5    |
| 16             | 34,5    | 23      |

3

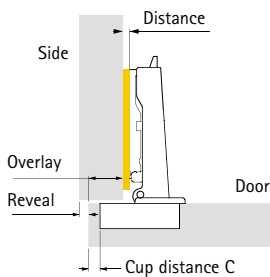

| Cup distance<br>C mm | Overlay mm |     |     |     |     |     |     |     |     |     |
|----------------------|------------|-----|-----|-----|-----|-----|-----|-----|-----|-----|
|                      | 10         | 11  | 12  | 13  | 14  | 15  | 16  | 17  | 18  | 19  |
| <b>Distance D mm</b> |            |     |     |     |     |     |     |     |     |     |
| 3                    | 6,0        | 5,0 | 4,0 | 3,0 | 2,0 | 1,0 | 0,0 |     |     |     |
| 4                    | 7,0        | 6,0 | 5,0 | 4,0 | 3,0 | 2,0 | 1,0 | 0,0 |     |     |
| 4,5                  | 7,5        | 6,5 | 5,5 | 4,5 | 3,5 | 2,5 | 1,5 | 0,5 |     |     |
| 5                    | 8,0        | 7,0 | 6,0 | 5,0 | 4,0 | 3,0 | 2,0 | 1,0 | 0,0 |     |
| 6                    | 9,0        | 8,0 | 7,0 | 6,0 | 5,0 | 4,0 | 3,0 | 2,0 | 1,0 | 0,0 |

\* Overlay adjustment – 4 mm, + 0,5 mm

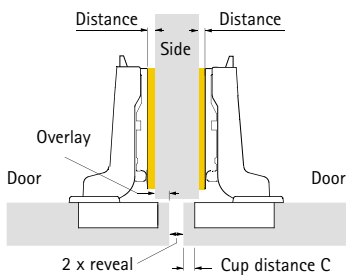

| Cup distance<br>C mm | Overlay mm |     |     |     |     |     |     |     |     |     |
|----------------------|------------|-----|-----|-----|-----|-----|-----|-----|-----|-----|
|                      | 0,5        | 1,5 | 2,5 | 3,5 | 4,5 | 5,5 | 6,5 | 7,5 | 8,5 | 9,5 |
| <b>Distance D mm</b> |            |     |     |     |     |     |     |     |     |     |
| 3                    | 6,0        | 5,0 | 4,0 | 3,0 | 2,0 | 1,0 | 0,0 |     |     |     |
| 4                    | 7,0        | 6,0 | 5,0 | 4,0 | 3,0 | 2,0 | 1,0 | 0,0 |     |     |
| 4,5                  | 7,5        | 6,5 | 5,5 | 4,5 | 3,5 | 2,5 | 1,5 | 0,5 |     |     |
| 5                    | 8,0        | 7,0 | 6,0 | 5,0 | 4,0 | 3,0 | 2,0 | 1,0 | 0,0 |     |
| 6                    | 9,0        | 8,0 | 7,0 | 6,0 | 5,0 | 4,0 | 3,0 | 2,0 | 1,0 | 0,0 |

\*Overlay adjustment – 4 mm, + 0,5 mm

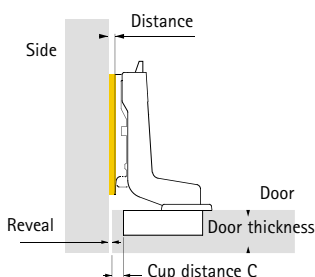

| Cup distance<br>C mm | Door thickness mm |     |     |     |     |     |     |     |     |     |     |     |     |
|----------------------|-------------------|-----|-----|-----|-----|-----|-----|-----|-----|-----|-----|-----|-----|
|                      | 16                | 17  | 18  | 19  | 20  | 21  | 22  | 23  | 24  | 25  | 26  | 27  | 28  |
| <b>Distance D mm</b> |                   |     |     |     |     |     |     |     |     |     |     |     |     |
| 3                    | 0,6               | 0,8 | 1,1 | 1,0 | 1,9 | 2,4 | 3,1 | 4,0 | 4,8 | 5,8 | 6,4 | 7,3 | 8,2 |
| 4                    | 1,5               | 1,7 | 2,0 | 2,4 | 2,8 | 3,3 | 3,8 | 4,5 | 5,3 | 6,3 | 7,0 | 7,8 | 8,7 |
| 4,5                  | 2,0               | 2,2 | 2,5 | 2,9 | 3,3 | 3,8 | 4,3 | 5,0 | 5,7 | 6,5 | 7,2 | 7,9 | 8,7 |
| 5                    | 2,5               | 2,7 | 3,0 | 3,4 | 3,8 | 4,3 | 4,8 | 5,5 | 6,1 | 6,8 | 7,5 | 8,4 | 9,2 |
| 6                    | 3,5               | 3,7 | 4,0 | 4,4 | 4,7 | 5,3 | 5,7 | 6,3 | 6,8 | 7,4 | 8,2 | 9,0 | 9,8 |

\*Reveal adjustment + 4 mm, – 0,5 mm

# Ecomat 9843 Fix

## Toolless fast-assembly

### Opening angle 110°

Door thickness from 15 mm

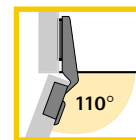
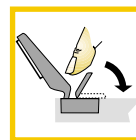

**Concealed hinges, snap-on assembly plus toolless cup assembly, integrated door overlay and depth adjustment.**

Opening angle 110°, cup diameter 35 mm

Small hole depth for door thickness 15 mm or larger.

Ecomat 9843 FIX hinges are snapped onto the mounting plate and also feature toolless cup assembly.

Depth adjustment +2 mm/-2 mm

Height adjustment via mounting plate +2 mm/-2 mm, see pages 3.110 - 3.112.

#### Cup version

**Cup T FIX**  
Toolless  
Nickel-plated steel

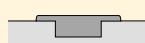

**Cup TH FIX**  
Toolless  
with pegs  
Nickel-plated steel



**Cup TB FIX**  
Toolless  
with pegs  
Nickel-plated steel



#### Hinge version

#### Mounting option

#### Article/order number

##### Ecomat 9843 FIX

- self-closing

Packaging unit 50 pcs

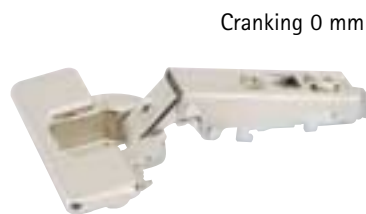

#### Full overlay

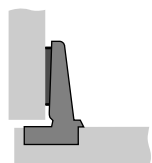

● **9843-T FIX**  
**079 045**

● **9843-TH FIX**  
**079 048**

● **9843-TB FIX**  
**079 051**

#### Door buffer Silent System



clip-on

**045 337**



screw-on

**042 001**



drill-in

**048 047**



#### Half overlay

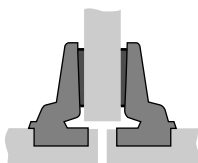

##### Ecomat 9843 FIX

- self-closing

Packaging unit 50 pcs

● **9843-T FIX**  
**079 046**

● **9843-TH FIX**  
**079 049**

● **9843-TB FIX**  
**079 052**

#### Door buffer Silent System



clip-on

**045 338**



screw-on

**042 001**



drill-in

**048 047**



#### Inset

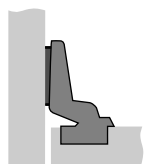

##### Ecomat 9843 FIX

- self-closing

Packaging unit 50 pcs

● **9843-T FIX**  
**079 047**

● **9843-TH FIX**  
**079 050**

● **9843-TB FIX**  
**079 053**

#### Door buffer Silent System



clip-on

**045 339**



screw-on

**048 048**

## Specification

Hettich Ecomat 9843 FIX  
 Snap-on assembly plus toolless cup assembly  
 Integrated overlay and depth adjustment  
 for door thickness from 15 mm  
 Opening angle 110°

## Cover cap for Ecomat hinges

Nickel-plated steel

Order no. **079 790**

PU = 50 pcs



| Cup distance<br>C mm   | Door thickness mm |     |     |     |     |     |     |     |     |     |     |
|--|-------------------|-----|-----|-----|-----|-----|-----|-----|-----|-----|-----|
|  | 15                | 16  | 17  | 18  | 19  | 20  | 21  | 22  | 23  | 24  | 25  |
| <b>Minimum reveal per door – allow for in distance calculation</b> |                   |     |     |     |     |     |     |     |     |     |     |
| Table entries apply to doors with 0 mm radius                      |                   |     |     |     |     |     |     |     |     |     |     |
| 3  | 0,5               | 0,6 | 0,8 | 1,1 | 1,5 | 1,9 | 2,4 | 3,1 | 4,0 | 4,8 | 5,8 |
| 4  | 0,4               | 0,5 | 0,7 | 1,0 | 1,4 | 1,8 | 2,3 | 2,8 | 3,5 | 4,3 | 5,3 |
| 4,5  | 0,4               | 0,5 | 0,7 | 1,0 | 1,4 | 1,8 | 2,3 | 2,8 | 3,5 | 4,2 | 5,1 |
| 5  | 0,4               | 0,5 | 0,7 | 1,0 | 1,4 | 1,8 | 2,3 | 2,8 | 3,5 | 4,1 | 4,8 |
| 6  | 0,4               | 0,5 | 0,7 | 1,0 | 1,4 | 1,7 | 2,3 | 2,7 | 3,3 | 3,8 | 4,4 |

The minimum reveal is reduced for doors with radii: 1 mm radius: table entry – 0,4 mm  
 3 mm radius: table entry – 1,2 mm

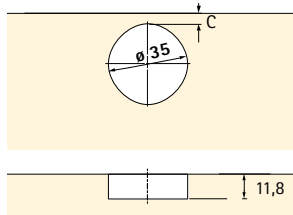

T FIX hole dimensions

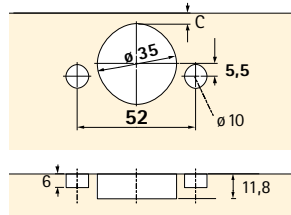

TH FIX hole dimensions

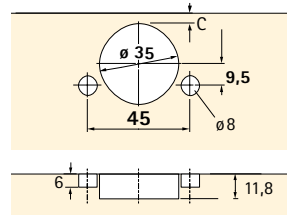

TB FIX hole dimensions

Door  
protrusion T for  
0 mm distance  
and 3 mm cup  
distance

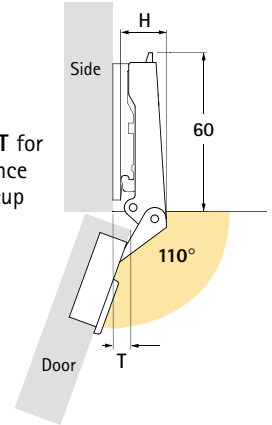

| Cranking<br>mm | H<br>mm | T<br>mm |
|----------------|---------|---------|
| 0              | 18,5    | 7       |
| 9,5            | 28      | 16,5    |
| 16             | 34,5    | 23      |

3

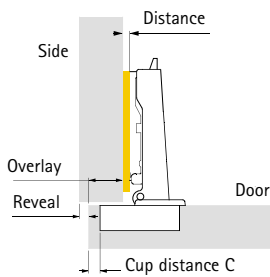

| Cup distance<br>C mm | Overlay mm |     |     |     |     |     |     |     |     |     |
|----------------------|------------|-----|-----|-----|-----|-----|-----|-----|-----|-----|
|                      | 10         | 11  | 12  | 13  | 14  | 15  | 16  | 17  | 18  | 19  |
| <b>Distance D mm</b> |            |     |     |     |     |     |     |     |     |     |
| 3                    | 6,0        | 5,0 | 4,0 | 3,0 | 2,0 | 1,0 | 0,0 |     |     |     |
| 4                    | 7,0        | 6,0 | 5,0 | 4,0 | 3,0 | 2,0 | 1,0 | 0,0 |     |     |
| 4,5                  | 7,5        | 6,5 | 5,5 | 4,5 | 3,5 | 2,5 | 1,5 | 0,5 |     |     |
| 5                    | 8,0        | 7,0 | 6,0 | 5,0 | 4,0 | 3,0 | 2,0 | 1,0 | 0,0 |     |
| 6                    | 9,0        | 8,0 | 7,0 | 6,0 | 5,0 | 4,0 | 3,0 | 2,0 | 1,0 | 0,0 |

\* Overlay adjustment – 4 mm, + 0,5 mm

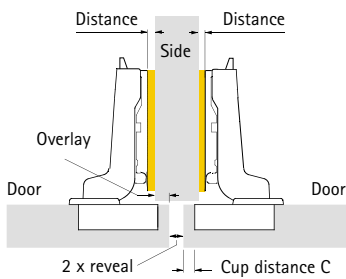

| Cup distance<br>C mm | Overlay mm |     |     |     |     |     |     |     |     |     |
|----------------------|------------|-----|-----|-----|-----|-----|-----|-----|-----|-----|
|                      | 0,5        | 1,5 | 2,5 | 3,5 | 4,5 | 5,5 | 6,5 | 7,5 | 8,5 | 9,5 |
| <b>Distance D mm</b> |            |     |     |     |     |     |     |     |     |     |
| 3                    | 6,0        | 5,0 | 4,0 | 3,0 | 2,0 | 1,0 | 0,0 |     |     |     |
| 4                    | 7,0        | 6,0 | 5,0 | 4,0 | 3,0 | 2,0 | 1,0 | 0,0 |     |     |
| 4,5                  | 7,5        | 6,5 | 5,5 | 4,5 | 3,5 | 2,5 | 1,5 | 0,5 |     |     |
| 5                    | 8,0        | 7,0 | 6,0 | 5,0 | 4,0 | 3,0 | 2,0 | 1,0 | 0,0 |     |
| 6                    | 9,0        | 8,0 | 7,0 | 6,0 | 5,0 | 4,0 | 3,0 | 2,0 | 1,0 | 0,0 |

\* Overlay adjustment – 4 mm, + 0,5 mm

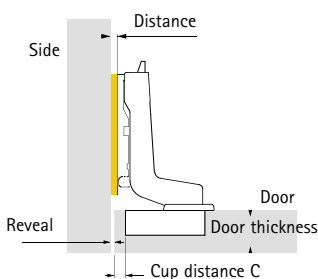

| Cup distance<br>C mm | Door thickness mm |     |     |     |     |     |     |     |     |     |     |     |     |
|----------------------|-------------------|-----|-----|-----|-----|-----|-----|-----|-----|-----|-----|-----|-----|
|                      | 16                | 17  | 18  | 19  | 20  | 21  | 22  | 23  | 24  | 25  | 26  | 27  | 28  |
| <b>Distance D mm</b> |                   |     |     |     |     |     |     |     |     |     |     |     |     |
| 3                    | 0,6               | 0,8 | 1,1 | 1,0 | 1,9 | 2,4 | 3,1 | 4,0 | 4,8 | 5,8 | 6,4 | 7,3 | 8,2 |
| 4                    | 1,5               | 1,7 | 2,0 | 2,4 | 2,8 | 3,3 | 3,8 | 4,5 | 5,3 | 6,3 | 7,0 | 7,8 | 8,7 |
| 4,5                  | 2,0               | 2,2 | 2,5 | 2,9 | 3,3 | 3,8 | 4,3 | 5,0 | 5,7 | 6,5 | 7,2 | 7,9 | 8,7 |
| 5                    | 2,5               | 2,7 | 3,0 | 3,4 | 3,8 | 4,3 | 4,8 | 5,5 | 6,1 | 6,8 | 7,5 | 8,4 | 9,2 |
| 6                    | 3,5               | 3,7 | 4,0 | 4,4 | 4,7 | 5,3 | 5,7 | 6,3 | 6,8 | 7,4 | 8,2 | 9,0 | 9,8 |

\* Reveal adjustment + 4 mm, – 0,5 mm

# Intermat 9944

## Fast-assembly hinge

### Opening angle 125°

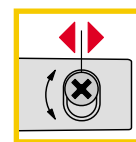
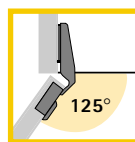

**Concealed hinges, snap-on assembly, integrated door overlay and eccentric depth adjustment.**

Opening angle 125°, cup diameter 35 mm.

Interimat 9944 hinges are snapped onto the mounting plate.

Depth adjustment via eccentric screw -0,5 mm/+3,5 mm.

Height adjustment via mounting plate +2 mm/-2 mm, see pages 3.110 - 3.112.

Cup fixing screw  $\varnothing$  3,5 x 13 mm nickel-plated, for cup T 42

Order no. 048 296, PU 200

#### Cup version

##### Cup T 42

Screw-on  
Nickel-plated  
steel

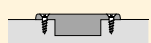

##### Cup T 43

Press-in  
Nickel-plated  
steel

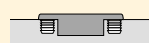

##### Cup TB 43

Press-in  
Nickel-plated  
steel



##### Flash cup

Fast-assembly  
Nickel-plated  
steel



#### Hinge version

#### Mounting option

#### Article/order number

##### Interimat 9944

- self-closing

Packaging unit 50 pcs

● 9944-  
T42  
073 905

● 9944-  
T43  
073 906

● 9944-  
TB 43  
073 907

● 9944-  
Flash  
073 908

##### Door buffer Silent System

|  |          |         |
|--|----------|---------|
|  | clip-on  | 048 044 |
|  | screw-on | 042 001 |
|  | drill-in | 048 047 |



#### Full overlay

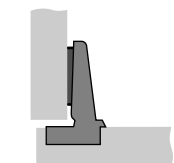

#### Half overlay

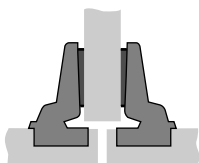

##### Interimat 9944

- self-closing

Packaging unit 50 pcs

● 9944-  
T42  
073 909

● 9944-  
T43  
073 910

● 9944-  
TB 43  
073 911

● 9944-  
Flash  
073 912

##### Door buffer Silent System

|  |          |         |
|--|----------|---------|
|  | clip-on  | 048 045 |
|  | screw-on | 042 001 |
|  | drill-in | 048 047 |

## Specification

Hettich Intermat 9944  
 Snap-on assembly  
 Eccentric depth adjustment  
 Opening angle 125°

### Cover cap for Intermat hinges

Nickel-plated steel  
**Order no. 013 300**  
 Black plastic  
**Order no. 048 043**  
 PU = 50 pcs



| Cup distance<br>C mm  | Door thickness mm |     |     |     |     |     |     |     |     |     |     |     |     |
|---|-------------------|-----|-----|-----|-----|-----|-----|-----|-----|-----|-----|-----|-----|
|   | 16                | 17  | 18  | 19  | 20  | 21  | 22  | 23  | 24  | 25  | 26  | 27  | 28  |
| Minimum reveal per door – allow for in distance calculation |                   |     |     |     |     |     |     |     |     |     |     |     |     |
| Table entries apply to doors with 0 mm radius               |                   |     |     |     |     |     |     |     |     |     |     |     |     |
| 3   | 1,3               | 1,6 | 1,9 | 2,3 | 2,8 | 3,3 | 3,9 | 4,6 | 5,3 | 6,1 | 6,9 | 7,7 | 8,6 |
| 4   | 1,3               | 1,6 | 1,9 | 2,3 | 2,7 | 3,1 | 3,7 | 4,3 | 5,0 | 5,7 | 6,5 | 7,3 | 8,1 |
| 4,5   | 1,2               | 1,5 | 1,8 | 2,2 | 2,6 | 3,0 | 3,6 | 4,2 | 4,9 | 5,6 | 6,4 | 7,2 | 7,9 |
| 5   | 1,2               | 1,5 | 1,8 | 2,1 | 2,6 | 3,0 | 3,5 | 4,1 | 4,8 | 5,5 | 6,2 | 6,9 | 7,7 |
| 5,5   | 1,2               | 1,5 | 1,8 | 2,1 | 2,5 | 2,9 | 3,4 | 4,0 | 4,6 | 5,3 | 6,0 | 6,7 | 7,4 |

Door  
 protrusion T for  
 0 mm distance  
 and 3 mm cup  
 distance

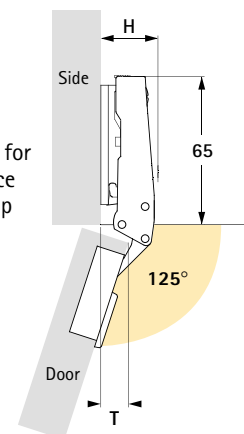

The minimum reveal is reduced for doors with radii:  
 1 mm radius: table entry – 0,4 mm  
 3 mm radius: table entry – 1,2 mm

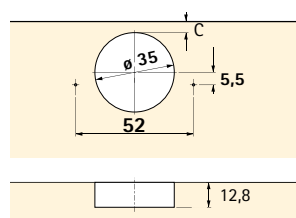

T42 hole dimensions

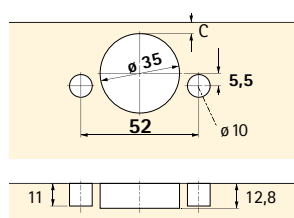

T43 / Flash hole dimensions

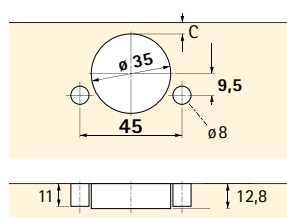

TB43 hole dimensions

| Cranking<br>mm | H<br>mm | T<br>mm |
|----------------|---------|---------|
| 0              | 18,5    | 8       |
| 9,5            | 28      | 17,5    |

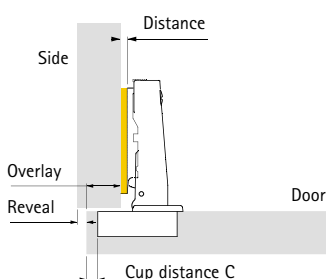

| Cup distance<br>C mm | Overlay mm |     |     |     |     |     |     |     |     |      |  |
|----------------------|------------|-----|-----|-----|-----|-----|-----|-----|-----|------|--|
|                      | 10         | 11  | 12  | 13  | 14  | 15  | 16  | 17  | 18  | 18,5 |  |
| Distance D mm        |            |     |     |     |     |     |     |     |     |      |  |
| 3                    | 6,0        | 5,0 | 4,0 | 3,0 | 2,0 | 1,0 | 0,0 |     |     |      |  |
| 4                    | 7,0        | 6,0 | 5,0 | 4,0 | 3,0 | 2,0 | 1,0 | 0,0 |     |      |  |
| 4,5                  | 7,5        | 6,5 | 5,5 | 4,5 | 3,5 | 2,5 | 1,5 | 0,5 |     |      |  |
| 5                    | 8,0        | 7,0 | 6,0 | 5,0 | 4,0 | 3,0 | 2,0 | 1,0 | 0,0 |      |  |
| 5,5                  | 8,5        | 7,5 | 6,5 | 5,5 | 4,5 | 3,5 | 2,5 | 1,5 | 0,5 | 0,0  |  |

\* Overlay adjustment – 4 mm, + 0,5 mm

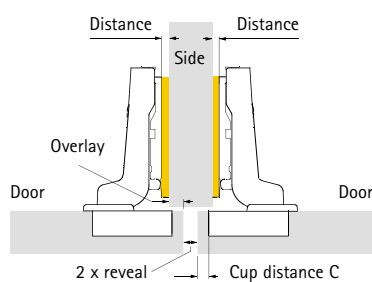

| Cup distance<br>C mm | Overlay mm |     |     |     |     |     |     |     |     |     |
|----------------------|------------|-----|-----|-----|-----|-----|-----|-----|-----|-----|
|                      | 0          | 1   | 2   | 3   | 4   | 5   | 6   | 7   | 8   | 9   |
| Distance D mm        |            |     |     |     |     |     |     |     |     |     |
| 3                    | 6,5        | 5,5 | 4,5 | 3,5 | 2,5 | 1,5 | 0,5 |     |     |     |
| 4                    | 7,5        | 6,5 | 5,5 | 4,5 | 3,5 | 2,5 | 1,5 | 0,5 |     |     |
| 4,5                  | 8,0        | 7,0 | 6,0 | 5,0 | 4,0 | 3,0 | 2,0 | 1,0 | 0,0 |     |
| 5                    | 8,5        | 7,5 | 6,5 | 5,5 | 4,5 | 3,5 | 2,5 | 1,5 | 0,5 |     |
| 5,5                  | 9,0        | 8,0 | 7,0 | 6,0 | 5,0 | 4,0 | 3,0 | 2,0 | 1,0 | 0,0 |

\* Overlay adjustment – 4 mm, + 0,5 mm

# Intermat 9944 Fix

## Toolless fast-assembly

### Opening angle 125°

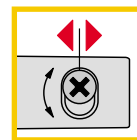
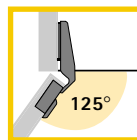
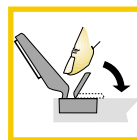

**Concealed hinges, snap-on assembly plus toolless cup assembly, integrated door overlay and eccentric depth adjustment.**

Opening angle 125°, cup diameter 35 mm.

Intermat 9944 FIX hinges are snapped onto the mounting plate and also feature toolless cup assembly.

Depth adjustment via eccentric screw -0,5 mm/+3,5 mm.

Height adjustment via mounting plate +2 mm/-2 mm, see pages 3.110 - 3.112.

#### Cup version

**Cup T FIX**  
Toolless  
Nickel-plated steel



**Cup TH FIX**  
Toolless  
with pegs  
Nickel-plated steel

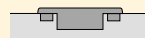

**Cup TB FIX**  
Toolless  
with pegs  
Nickel-plated steel

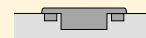

#### Hinge version

#### Mounting option

#### Article/order number

##### Intermat 9944 FIX

- self-closing



Packaging unit 50 pcs

● 9944-T FIX  
077 647

● 9944-TH FIX  
077 648

● 9944-TB FIX  
077 649

##### Door buffer Silent System

 clip-on  
 screw-on  
 drill-in

048 044

042 001

048 047

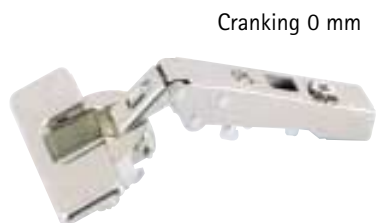

#### Full overlay

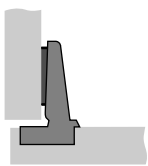

#### Half overlay

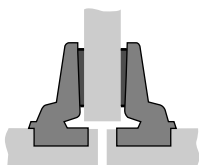

##### Intermat 9944 FIX

- self-closing



Packaging unit 50 pcs

● 9944-T FIX  
077 650

● 9944-TH FIX  
077 651

● 9944-TB FIX  
077 652

##### Door buffer Silent System

 clip-on  
 screw-on  
 drill-in

048 045

042 001

048 047

## Specification

Hettich Intermat 9944 FIX  
 Snap-on assembly plus  
 toolless cup assembly  
 Eccentric depth adjustment  
 Opening angle 125°

## Cover cap for Intermat hinges

Nickel-plated steel  
**Order no. 013 300**  
 Black plastic  
**Order no. 048 043**  
 PU = 50 pcs



| Cup distance<br>C mm  | Door thickness mm |     |     |     |     |     |     |     |     |     |     |     |     |
|---|-------------------|-----|-----|-----|-----|-----|-----|-----|-----|-----|-----|-----|-----|
|   | 16                | 17  | 18  | 19  | 20  | 21  | 22  | 23  | 24  | 25  | 26  | 27  | 28  |
| Minimum reveal per door – allow for in distance calculation |                   |     |     |     |     |     |     |     |     |     |     |     |     |
| Table entries apply to doors with 0 mm radius               |                   |     |     |     |     |     |     |     |     |     |     |     |     |
| 3   | 1,3               | 1,6 | 1,9 | 2,3 | 2,8 | 3,3 | 3,9 | 4,6 | 5,3 | 6,1 | 6,9 | 7,7 | 8,6 |
| 4   | 1,3               | 1,6 | 1,9 | 2,3 | 2,7 | 3,1 | 3,7 | 4,3 | 5,0 | 5,7 | 6,5 | 7,3 | 8,1 |
| 4,5   | 1,2               | 1,5 | 1,8 | 2,2 | 2,6 | 3,0 | 3,6 | 4,2 | 4,9 | 5,6 | 6,4 | 7,2 | 7,9 |
| 5   | 1,2               | 1,5 | 1,8 | 2,1 | 2,6 | 3,0 | 3,5 | 4,1 | 4,8 | 5,5 | 6,2 | 6,9 | 7,7 |
| 5,5   | 1,2               | 1,5 | 1,8 | 2,1 | 2,5 | 2,9 | 3,4 | 4,0 | 4,6 | 5,3 | 6,0 | 6,7 | 7,4 |

The minimum reveal is reduced for doors with radii:  
 1 mm radius: table entry – 0,4 mm  
 3 mm radius: table entry – 1,2 mm

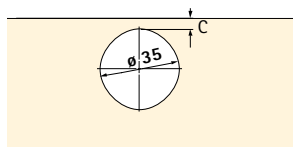

T FIX hole dimensions

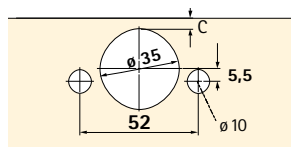

TH FIX hole dimensions

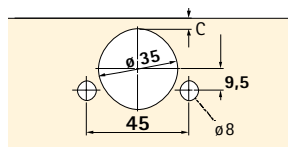

TB FIX hole dimensions

Door  
 protrusion T for  
 0 mm distance  
 and 3 mm cup  
 distance

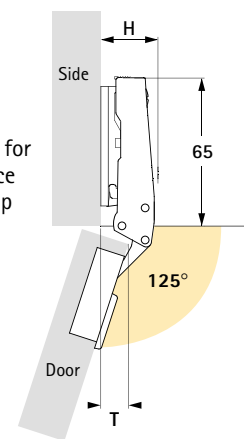

| Cranking<br>mm | H<br>mm | T<br>mm |
|----------------|---------|---------|
| 0              | 18,5    | 8       |
| 9,5            | 28      | 17,5    |

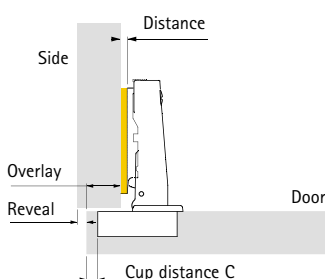

| Cup distance<br>C mm | Overlay mm |     |     |     |     |     |     |     |     |      |  |
|----------------------|------------|-----|-----|-----|-----|-----|-----|-----|-----|------|--|
|                      | 10         | 11  | 12  | 13  | 14  | 15  | 16  | 17  | 18  | 18,5 |  |
| Distance D mm        |            |     |     |     |     |     |     |     |     |      |  |
| 3                    | 6,0        | 5,0 | 4,0 | 3,0 | 2,0 | 1,0 | 0,0 |     |     |      |  |
| 4                    | 7,0        | 6,0 | 5,0 | 4,0 | 3,0 | 2,0 | 1,0 | 0,0 |     |      |  |
| 4,5                  | 7,5        | 6,5 | 5,5 | 4,5 | 3,5 | 2,5 | 1,5 | 0,5 |     |      |  |
| 5                    | 8,0        | 7,0 | 6,0 | 5,0 | 4,0 | 3,0 | 2,0 | 1,0 | 0,0 |      |  |
| 5,5                  | 8,5        | 7,5 | 6,5 | 5,5 | 4,5 | 3,5 | 2,5 | 1,5 | 0,5 | 0,0  |  |

\* Overlay adjustment – 4 mm, + 0,5 mm

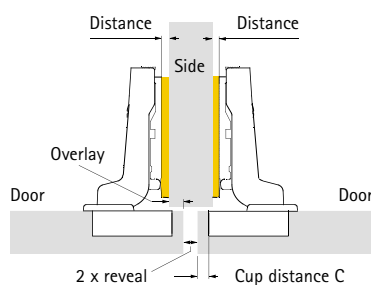

| Cup distance<br>C mm | Overlay mm |     |     |     |     |     |     |     |     |     |
|----------------------|------------|-----|-----|-----|-----|-----|-----|-----|-----|-----|
|                      | 0          | 1   | 2   | 3   | 4   | 5   | 6   | 7   | 8   | 9   |
| Distance D mm        |            |     |     |     |     |     |     |     |     |     |
| 3                    | 6,5        | 5,5 | 4,5 | 3,5 | 2,5 | 1,5 | 0,5 |     |     |     |
| 4                    | 7,5        | 6,5 | 5,5 | 4,5 | 3,5 | 2,5 | 1,5 | 0,5 |     |     |
| 4,5                  | 8,0        | 7,0 | 6,0 | 5,0 | 4,0 | 3,0 | 2,0 | 1,0 | 0,0 |     |
| 5                    | 8,5        | 7,5 | 6,5 | 5,5 | 4,5 | 3,5 | 2,5 | 1,5 | 0,5 |     |
| 5,5                  | 9,0        | 8,0 | 7,0 | 6,0 | 5,0 | 4,0 | 3,0 | 2,0 | 1,0 | 0,0 |

\* Overlay adjustment – 4 mm, + 0,5 mm

# Intermat 9956

## Fast-assembly hinge

### Opening angle 165°-120°

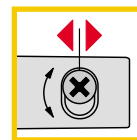
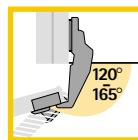

**Concealed wide-angle hinge, snap-on assembly, integrated door overlay and eccentric depth adjustment.**

Opening angle 165° – the opening angle can be variably adjusted up to 120° with the adjustment screw (Order-no. 079 791)\*.

Cup diameter 35 mm.

The wide-angle hinge enables an optimal reveal (hairline reveal). Negative door protrusion.

Interimat 9956 hinges are snapped onto the mounting plate.

Depth adjustment via eccentric screw -0,5 mm/+3,5 mm.

Height adjustment via mounting plate +2 mm/-2 mm, see pages 3.110 - 3.112.

Cup fixing screw  $\varnothing$  3,5 x 13 mm nickel-plated, for cup T 42

Order no. 048 296, PU 200

#### Cup version

##### Cup T 42

Screw-on  
Nickel-plated  
steel

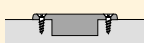

##### Cup T 43

Press-in  
Nickel-plated  
steel

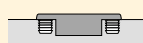

##### Cup TB 43

Press-in  
Nickel-plated  
steel

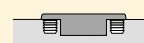

##### Flash cup

Fast-assembly  
Nickel-plated  
steel



#### Hinge version

#### Mounting option

#### Article/order number



Cranking 0 mm

#### Full overlay

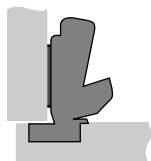

#### Interimat 9956

- self-closing

Packaging unit 50 pcs

● 9956-  
T42  
072 947

● 9956-  
T43  
072 948

● 9956-  
TB 43  
072 949

● 9956-  
Flash  
072 124

#### Door buffer Silent System



screw-on

042 001



drill-in

048 047



Cranking 9,5 mm

#### Half overlay

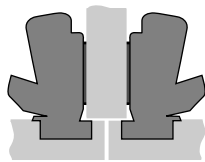

#### Interimat 9956

- self-closing

Packaging unit 50 pcs

● 9956-  
T42  
072 961

● 9956-  
T43  
072 962

● 9956-  
TB 43  
072 963

● 9956-  
Flash  
072 964

#### Door buffer Silent System



screw-on

042 001



drill-in

048 047

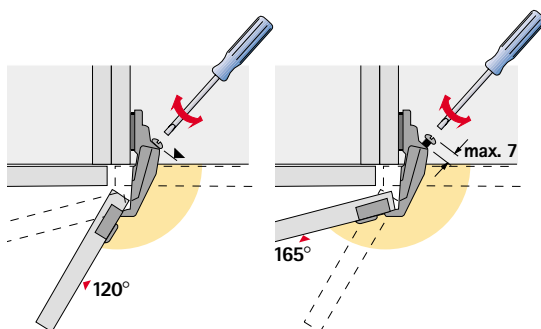

\* Opening angle 165° – stepless adjustment of the opening angle up to 120° via the adjustment screw M5x14 mm.

#### Adjustment screw M5 x14 mm

| Order no. | PU     |
|-----------|--------|
| 079 791   | 50 pcs |

## Specification

Hettich Intermat 9956

Snap-on assembly, eccentric depth adjustment

Hairline reveal for up to 19 mm doors

Negative door protrusion

Stepless adjustment of opening angle 165°-120°

| Cup distance<br>C mm | Door thickness mm |    |    |    |
|----------------------|-------------------|----|----|----|
|                      | 16                | 17 | 18 | 19 |

**Minimum reveal per door** – allow for in distance calculation  
Table entries apply to doors with 0 mm radius

|     |   |   |   |   |
|-----|---|---|---|---|
| 3   | 0 | 0 | 0 | 0 |
| 4   | 0 | 0 | 0 | 0 |
| 4,5 | 0 | 0 | 0 | 0 |
| 5   | 0 | 0 | 0 | 0 |
| 6   | 0 | 0 | 0 | 0 |

The minimum reveal for doors up to 19 mm thick is 0 mm.  
A trial assembly is recommended for doors thicker than 19 mm (max. door thickness 25 mm).

The minimum reveal is reduced for doors with radii: 1 mm radius: table entry – 0,4 mm  
3 mm radius: table entry – 1,2 mm

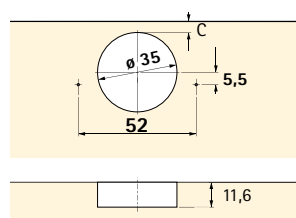

T42 hole dimensions

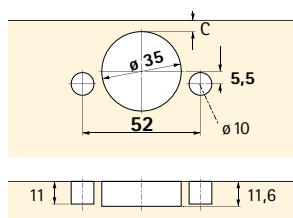

T43 / Flash hole dimensions

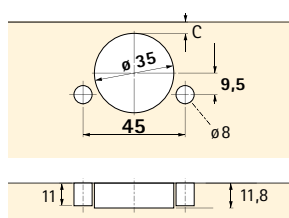

TB43 hole dimensions

No door protrusion T for 0 mm distance and 3 mm cup distance, unrestricted runner movement.

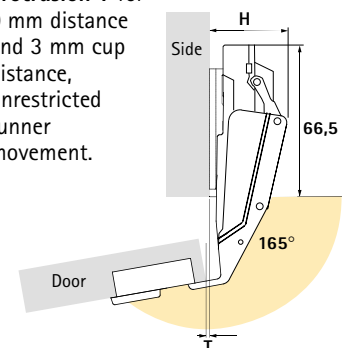

| Cranking mm | H mm | T mm |
|-------------|------|------|
| 0           | 46   | -1,5 |
| 9,5         | 55,5 | 8    |

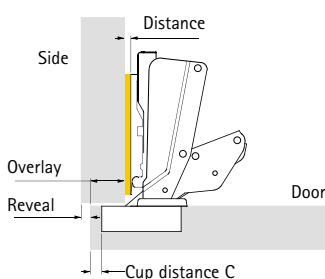

| Cup distance<br>C mm | Overlay mm |     |     |     |     |     |     |     |     |     |
|----------------------|------------|-----|-----|-----|-----|-----|-----|-----|-----|-----|
|                      | 10         | 11  | 12  | 13  | 14  | 15  | 16  | 17  | 18  | 19  |
| 3                    | 6,0        | 5,0 | 4,0 | 3,0 | 2,0 | 1,0 | 0,0 |     |     |     |
| 4                    | 7,0        | 6,0 | 5,0 | 4,0 | 3,0 | 2,0 | 1,0 | 0,0 |     |     |
| 4,5                  | 7,5        | 6,5 | 5,5 | 4,5 | 3,5 | 2,5 | 1,5 | 0,5 |     |     |
| 5                    | 8,0        | 7,0 | 6,0 | 5,0 | 4,0 | 3,0 | 2,0 | 1,0 | 0,0 |     |
| 6                    | 9,0        | 8,0 | 7,0 | 6,0 | 5,0 | 4,0 | 3,0 | 2,0 | 1,0 | 0,0 |

\* Overlay adjustment – 4 mm, + 0,5 mm

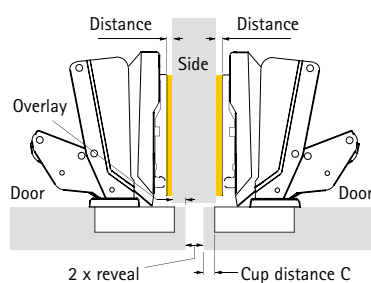

| Cup distance<br>C mm | Overlay mm |     |     |     |     |     |     |     |     |     |
|----------------------|------------|-----|-----|-----|-----|-----|-----|-----|-----|-----|
|                      | 0          | 1   | 2   | 3   | 4   | 5   | 6   | 7   | 8   | 9   |
| 3                    | 6,5        | 5,5 | 4,5 | 3,5 | 2,5 | 1,5 | 0,5 | 0,0 |     |     |
| 4                    | 7,5        | 6,5 | 5,5 | 4,5 | 3,5 | 2,5 | 1,5 | 0,5 |     |     |
| 4,5                  | 8,0        | 7,0 | 6,0 | 5,0 | 4,0 | 3,0 | 2,0 | 1,0 | 0,0 |     |
| 5                    | 8,5        | 7,5 | 6,5 | 5,5 | 4,5 | 3,5 | 2,5 | 1,5 | 0,5 |     |
| 6                    | 9,5        | 8,5 | 7,5 | 6,5 | 5,5 | 4,5 | 3,5 | 2,5 | 1,5 | 0,5 |

\* Overlay adjustment – 4 mm, + 0,5 mm

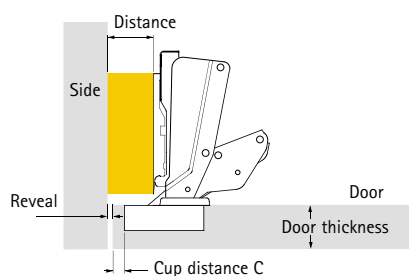

| Cup distance<br>C mm | Reveal 1 mm   |   |
|----------------------|---------------|---|
|                      | Distance (mm) | Hole line position for inset door = hole line 37 mm + door thickness + 1 mm |
| 3                    | 7,5           |   |
| 4                    | 8,5           |   |
| 4,5                  | 9,0           |   |
| 5                    | 9,5           |   |
| 6                    | 10,5          |   |

\* Reveal adjustment + 4 mm, – 0,5 mm

# Intermat 9956 FIX

## Toolless fast-assembly

### Opening angle 165°-120°

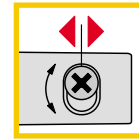
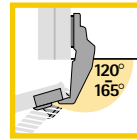
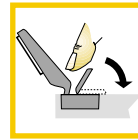

**Concealed wide-angle hinge, snap-on assembly plus toolless cup assembly, integrated door overlay and eccentric depth adjustment.**

Opening angle 165° – the opening angle can be variably adjusted up to 120° with the adjustment screw (Order-no. 079 791)\*. Cup diameter 35 mm.

The wide-angle hinge results in optimal reveal (hairline reveal). Negative door protrusion.

Intermat 9956 FIX hinges are snapped onto the mounting plate and feature toolless cup assembly.

Depth adjustment via eccentric screw -0,5 mm/+3,5 mm.

Height adjustment via mounting plate +2 mm/-2 mm, see pages 3.110 - 3.112.

#### Cup version

**Cup T FIX**  
Toolless  
Nickel-plated steel

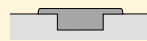

**Cup TH FIX**  
Toolless  
with pegs  
Nickel-plated steel

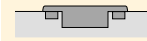

**Cup TB FIX**  
Toolless  
with pegs  
Nickel-plated steel

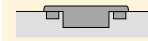

#### Hinge version

#### Mounting option

#### Article/order number



#### Full overlay

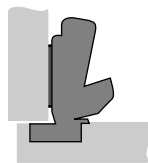

#### Intermat 9956 FIX

- self-closing

Packaging unit 50 pcs

● 9956-T FIX  
077 659

● 9956-TH FIX  
077 660

● 9956-TB FIX  
077 661

#### Door buffer Silent System



screw-on

042 001



drill-in

048 047



#### Half overlay

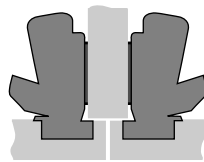

#### Intermat 9956 FIX

- self-closing

Packaging unit 50 pcs

● 9956-T FIX  
077 665

● 9956-TH FIX  
077 666

● 9956-TB FIX  
077 667

#### Door buffer Silent System



screw-on

042 001



drill-in

048 047

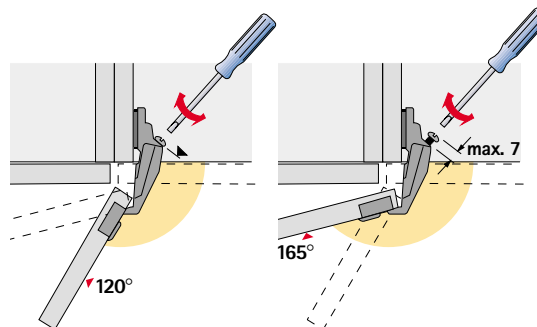

\* Opening angle 165° – stepless adjustment of the opening angle up to 120° via the adjustment screw M5x14 mm.

#### Adjustment screw M5 x14 mm

| Order no. | PU     |
|-----------|--------|
| 079 791   | 50 pcs |

# Specification

Hettich Intermat 9956 FIX

Snap-on assembly plus toolless cup assembly and eccentric depth adjustment

For door thicknesses up to 19 mm minimum reveal application, negative door protrusion

Stepless adjustment of opening angle 165°-120°

| Cup distance<br>C mm  | Door thickness mm |    |    |    |
|---|-------------------|----|----|----|
|   | 16                | 17 | 18 | 19 |
| <b>Minimum reveal per door – allow for in distance calculation</b><br>Table entries apply to doors with 0 mm radius |                   |    |    |    |
| 3   | 0                 | 0  | 0  | 0  |
| 4   | 0                 | 0  | 0  | 0  |
| 4,5   | 0                 | 0  | 0  | 0  |
| 5   | 0                 | 0  | 0  | 0  |
| 6   | 0                 | 0  | 0  | 0  |

The minimum reveal for doors up to 19 mm thick is 0 mm. A trial assembly is recommended for doors thicker than 19 mm (max. door thickness 25 mm).

The minimum reveal is reduced for doors with radii: 1 mm radius: table entry – 0,4 mm  
3 mm radius: table entry – 1,2 mm

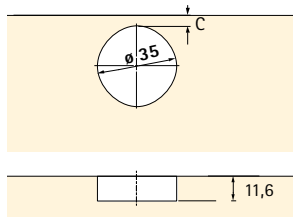

T FIX hole dimensions

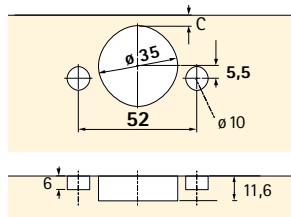

TH FIX hole dimensions

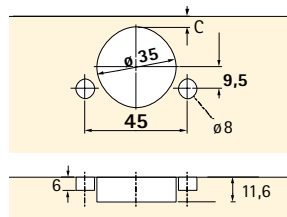

TB FIX hole dimensions

No door protrusion T for 0 mm distance and 3 mm cup distance, unrestricted runner movement.

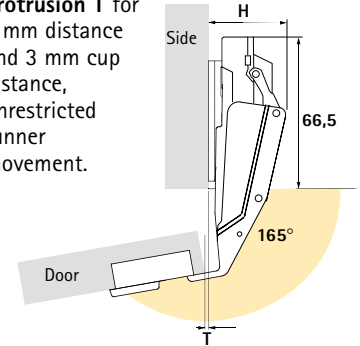

| Cranking mm | H mm | T mm |
|-------------|------|------|
| 0           | 46   | -1,5 |
| 9,5         | 55,5 | 8    |

3

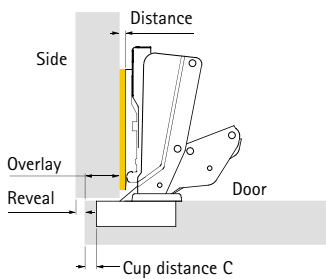

| Cup distance<br>C mm | Overlay mm |     |     |     |     |     |     |     |     |     |
|----------------------|------------|-----|-----|-----|-----|-----|-----|-----|-----|-----|
|                      | 10         | 11  | 12  | 13  | 14  | 15  | 16  | 17  | 18  | 19  |
| <b>Distance D mm</b> |            |     |     |     |     |     |     |     |     |     |
| 3                    | 6,0        | 5,0 | 4,0 | 3,0 | 2,0 | 1,0 | 0,0 |     |     |     |
| 4                    | 7,0        | 6,0 | 5,0 | 4,0 | 3,0 | 2,0 | 1,0 | 0,0 |     |     |
| 4,5                  | 7,5        | 6,5 | 5,5 | 4,5 | 3,5 | 2,5 | 1,5 | 0,5 |     |     |
| 5                    | 8,0        | 7,0 | 6,0 | 5,0 | 4,0 | 3,0 | 2,0 | 1,0 | 0,0 |     |
| 6                    | 9,0        | 8,0 | 7,0 | 6,0 | 5,0 | 4,0 | 3,0 | 2,0 | 1,0 | 0,0 |

\* Overlay adjustment – 4 mm, + 0,5 mm

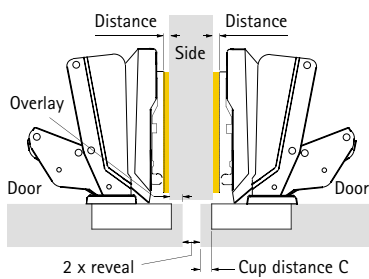

| Cup distance<br>C mm | Overlay mm |     |     |     |     |     |     |     |     |     |
|----------------------|------------|-----|-----|-----|-----|-----|-----|-----|-----|-----|
|                      | 0          | 1   | 2   | 3   | 4   | 5   | 6   | 7   | 8   | 9   |
| <b>Distance D mm</b> |            |     |     |     |     |     |     |     |     |     |
| 3                    | 6,5        | 5,5 | 4,5 | 3,5 | 2,5 | 1,5 | 0,5 | 0,0 |     |     |
| 4                    | 7,5        | 6,5 | 5,5 | 4,5 | 3,5 | 2,5 | 1,5 | 0,5 |     |     |
| 4,5                  | 8,0        | 7,0 | 6,0 | 5,0 | 4,0 | 3,0 | 2,0 | 1,0 | 0,0 |     |
| 5                    | 8,5        | 7,5 | 6,5 | 5,5 | 4,5 | 3,5 | 2,5 | 1,5 | 0,5 |     |
| 6                    | 9,5        | 8,5 | 7,5 | 6,5 | 5,5 | 4,5 | 3,5 | 2,5 | 1,5 | 0,5 |

\* Overlay adjustment – 4 mm, + 0,5 mm

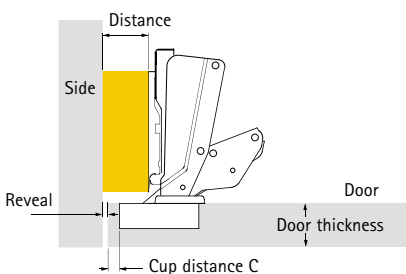

| Cup distance<br>C mm | Reveal 1 mm   |   |
|----------------------|---------------|---|
|                      | Distance (mm) | Hole line position for inset door = hole line 37 mm + door thickness + 1 mm |
| 3                    | 7,5           |   |
| 4                    | 8,5           |   |
| 4,5                  | 9,0           |   |
| 5                    | 9,5           |   |
| 6                    | 10,5          |   |

\* Reveal adjustment + 4 mm, – 0,5 mm

# Intermat 9936

## Fast-assembly hinge

### for profile doors up to 32 mm

### Opening angle 95°

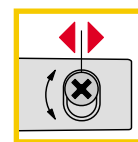
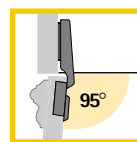

**Concealed hinge, snap-on assembly, integrated door overlay and eccentric depth adjustment.**

Opening angle 95°, cup diameter 35 mm.

The hinge enables an optimum reveal (hairline reveal) for profile doors.

For technical details of door contours, see page 3.50.

Intermat 9936 hinges are snapped onto the mounting plate.

Depth adjustment via eccentric screw -0,5 mm/+3,5 mm.

Height adjustment via mounting plate +2 mm/-2 mm, see pages 3.110 - 3.112.

Cup fixing screw  $\varnothing$  3,5 x 13 mm nickel-plated, for cup T 42

Order no. 048 296, PU 200

#### Cup version

##### Cup T 42

Screw-on  
Nickel-plated  
steel

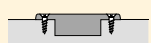

##### Cup T 43

Press-in  
Nickel-plated  
steel

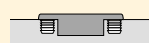

##### Cup TB 43

Press-in  
Nickel-plated  
steel



##### Flash cup

Fast-assembly  
Nickel-plated  
steel



#### Hinge version

#### Mounting option

#### Article/order number

##### Intermat 9936

- self-closing

Packaging unit 50 pcs

● 9936-  
T42  
073 913

● 9936-  
T43  
073 914

● 9936-  
TB 43  
073 915

● 9936-  
Flash  
073 916

##### Door buffer Silent System



clip-on

048 044



screw-on

042 001



drill-in

048 047



#### Full overlay

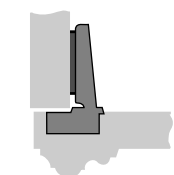

#### Half overlay

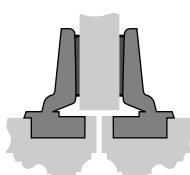

##### Intermat 9936

- self-closing

Packaging unit 50 pcs

● 9936-  
T42  
073 917

● 9936-  
T43  
073 918

● 9936-  
TB 43  
073 919

● 9936-  
Flash  
073 920

##### Door buffer Silent System



clip-on

048 045



screw-on

042 001



drill-in

048 047



#### Inset



##### Intermat 9936

- self-closing

Packaging unit 50 pcs

● 9936-  
T42  
073 921

● 9936-  
T43  
073 922

● 9936-  
TB 43  
073 923

● 9936-  
Flash  
073 924

##### Door buffer Silent System



clip-on

048 046



screw-on

048 048

## Specification

Hettich Intermat 9936  
 Snap-on assembly  
 Eccentric depth adjustment  
 for door thickness up to 32 mm  
 Opening angle 95°

### Cover cap for Intermat hinges

Nickel-plated steel  
**Order no. 013 300**  
 Black plastic  
**Order no. 048 043**  
 PU = 50 pcs

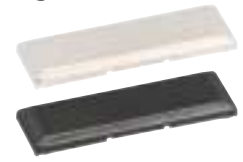

| Cup distance<br>C mm   | Door thickness mm |     |     |     |     |     |     |     |     |     |     |     |     |     |     |     |     |
|--|-------------------|-----|-----|-----|-----|-----|-----|-----|-----|-----|-----|-----|-----|-----|-----|-----|-----|
|  | 16                | 17  | 18  | 19  | 20  | 21  | 22  | 23  | 24  | 25  | 26  | 27  | 28  | 29  | 30  | 31  | 32  |
| <b>Minimum reveal per door – allow for in distance calculation</b> |                   |     |     |     |     |     |     |     |     |     |     |     |     |     |     |     |     |
| Table entries apply to doors with 0 mm radius                      |                   |     |     |     |     |     |     |     |     |     |     |     |     |     |     |     |     |
| 3  | 0,4               | 0,6 | 0,8 | 1,0 | 1,2 | 1,5 | 1,8 | 2,1 | 2,5 | 2,9 | 3,4 | 4,0 | 4,9 | 5,7 | 6,6 | 7,5 | 8,4 |
| 4  | 0,4               | 0,6 | 0,8 | 1,0 | 1,2 | 1,5 | 1,8 | 2,1 | 2,5 | 2,8 | 3,3 | 3,8 | 4,5 | 5,3 | 6,1 | 7,0 | 7,9 |
| 4,5  | 0,4               | 0,6 | 0,8 | 1,0 | 1,2 | 1,5 | 1,8 | 2,1 | 2,5 | 2,7 | 3,2 | 3,7 | 4,4 | 5,1 | 5,9 | 6,7 | 7,6 |
| 5  | 0,4               | 0,6 | 0,8 | 1,0 | 1,2 | 1,4 | 1,7 | 2,0 | 2,4 | 2,7 | 3,2 | 3,6 | 4,2 | 4,9 | 5,7 | 6,5 | 7,4 |
| 6  | 0,4               | 0,6 | 0,8 | 1,0 | 1,2 | 1,4 | 1,7 | 2,0 | 2,3 | 2,6 | 3,1 | 3,5 | 4,0 | 4,6 | 5,3 | 6,1 | 6,9 |
| 7  | 0,4               | 0,5 | 0,7 | 0,9 | 1,1 | 1,3 | 1,6 | 1,9 | 2,2 | 2,6 | 3,0 | 3,4 | 3,9 | 4,4 | 5,0 | 5,7 | 6,5 |
| 8  | 0,4               | 0,5 | 0,7 | 0,9 | 1,1 | 1,3 | 1,6 | 1,8 | 2,1 | 2,5 | 2,9 | 3,3 | 3,7 | 4,2 | 4,8 | 5,4 | 6,1 |

Door protrusion T for 0 mm distance and 3 mm cup distance

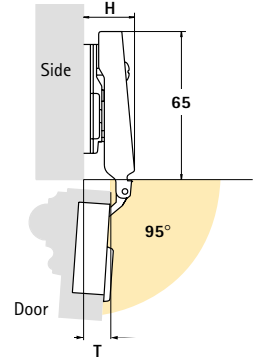

The minimum reveal is reduced for doors with radii:  
 1 mm radius: table entry – 0,4 mm  
 3 mm radius: table entry – 1,2 mm

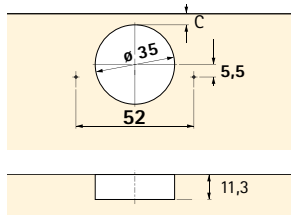

T42 hole dimensions

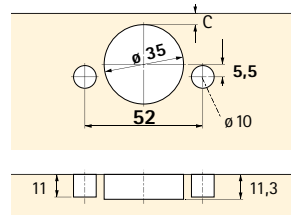

T43 / Flash hole dimensions

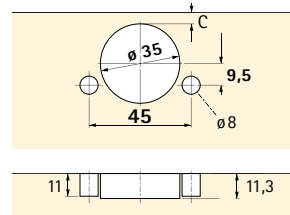

TB43 hole dimensions

| Cranking mm | H mm | T mm |
|-------------|------|------|
| 0           | 18,5 | 10   |
| 9,5         | 28   | 19,5 |
| 16          | 34,5 | 26   |

3

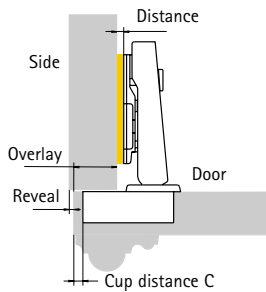

| Cup distance<br>C mm | Overlay mm |      |     |     |     |     |     |     |     |     |     |     |  |
|----------------------|------------|------|-----|-----|-----|-----|-----|-----|-----|-----|-----|-----|--|
|                      | 10         | 11   | 12  | 13  | 14  | 15  | 16  | 17  | 18  | 19  | 20  | 21  |  |
| <b>Distance D mm</b> |            |      |     |     |     |     |     |     |     |     |     |     |  |
| 3                    | 6,0        | 5,0  | 4,0 | 3,0 | 2,0 | 1,0 | 0,0 |     |     |     |     |     |  |
| 4                    | 7,0        | 6,0  | 5,0 | 4,0 | 3,0 | 2,0 | 1,0 | 0,0 |     |     |     |     |  |
| 4,5                  | 7,5        | 6,5  | 5,5 | 4,5 | 3,5 | 2,5 | 1,5 | 0,5 |     |     |     |     |  |
| 5                    | 8,0        | 7,0  | 6,0 | 5,0 | 4,0 | 3,0 | 2,0 | 1,0 | 0,0 |     |     |     |  |
| 6                    | 9,0        | 8,0  | 7,0 | 6,0 | 5,0 | 4,0 | 3,0 | 2,0 | 1,0 | 0,0 |     |     |  |
| 7                    | 10,0       | 9,0  | 8,0 | 7,0 | 6,0 | 5,0 | 4,0 | 3,0 | 2,0 | 1,0 | 0,0 |     |  |
| 8                    | 11,0       | 10,0 | 9,0 | 8,0 | 7,0 | 6,0 | 5,0 | 4,0 | 3,0 | 2,0 | 1,0 | 0,0 |  |

\* Overlay adjustment + 2 mm / - 4 mm

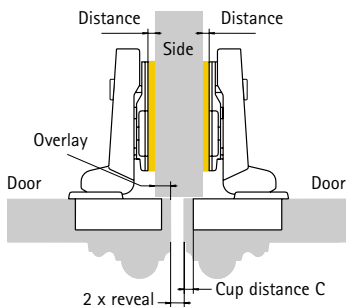

| Cup distance<br>C mm | Overlay mm |      |     |     |     |     |     |     |     |     |     |     |  |
|----------------------|------------|------|-----|-----|-----|-----|-----|-----|-----|-----|-----|-----|--|
|                      | 0          | 1    | 2   | 3   | 4   | 5   | 6   | 7   | 8   | 9   | 10  | 11  |  |
| <b>Distance D mm</b> |            |      |     |     |     |     |     |     |     |     |     |     |  |
| 3                    | 6,5        | 5,5  | 4,5 | 3,5 | 2,5 | 1,5 | 0,5 |     |     |     |     |     |  |
| 4                    | 7,5        | 6,5  | 5,5 | 4,5 | 3,5 | 2,5 | 1,5 | 0,5 |     |     |     |     |  |
| 4,5                  | 8,0        | 7,0  | 6,0 | 5,0 | 4,0 | 3,0 | 2,0 | 1,0 | 0,0 |     |     |     |  |
| 5                    | 8,5        | 7,5  | 6,5 | 5,5 | 4,5 | 3,5 | 2,5 | 1,5 | 0,5 |     |     |     |  |
| 6                    | 9,5        | 8,5  | 7,5 | 6,5 | 5,5 | 4,5 | 3,5 | 2,5 | 1,5 | 0,5 |     |     |  |
| 7                    | 10,5       | 9,5  | 8,5 | 7,5 | 6,5 | 5,5 | 4,5 | 3,5 | 2,5 | 1,5 | 0,5 |     |  |
| 8                    | 11,5       | 10,5 | 9,5 | 8,5 | 7,5 | 6,5 | 5,5 | 4,5 | 3,5 | 2,5 | 1,5 | 0,5 |  |

\* Overlay adjustment + 2 mm / - 4 mm

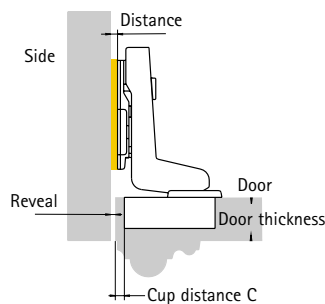

| Cup distance<br>C mm | Door thickness mm |     |     |     |     |     |     |     |     |     |     |     |     |     |     |      |      |
|----------------------|-------------------|-----|-----|-----|-----|-----|-----|-----|-----|-----|-----|-----|-----|-----|-----|------|------|
|                      | 16                | 17  | 18  | 19  | 20  | 21  | 22  | 23  | 24  | 25  | 26  | 27  | 28  | 29  | 30  | 31   | 32   |
| <b>Distance D mm</b> |                   |     |     |     |     |     |     |     |     |     |     |     |     |     |     |      |      |
| 3                    | 0,4               | 0,6 | 0,8 | 1,0 | 1,2 | 1,5 | 1,8 | 2,1 | 2,5 | 2,9 | 3,4 | 4,0 | 4,9 | 5,7 | 6,6 | 7,5  | 8,4  |
| 4                    | 1,4               | 1,6 | 1,8 | 2,0 | 2,2 | 2,5 | 2,8 | 3,1 | 3,5 | 3,8 | 4,3 | 4,8 | 5,5 | 6,3 | 7,1 | 8,0  | 8,9  |
| 4,5                  | 1,9               | 2,1 | 2,3 | 2,5 | 2,7 | 3,0 | 3,3 | 3,6 | 4,0 | 4,3 | 4,8 | 5,2 | 5,9 | 6,6 | 7,4 | 8,3  | 9,2  |
| 5                    | 2,4               | 2,6 | 2,8 | 3,0 | 3,2 | 3,4 | 3,7 | 4,0 | 4,4 | 4,7 | 5,2 | 5,6 | 6,2 | 6,9 | 7,7 | 8,5  | 9,4  |
| 6                    | 3,4               | 3,6 | 3,8 | 4,0 | 4,2 | 4,4 | 4,7 | 5,0 | 5,3 | 5,6 | 6,1 | 6,5 | 7,0 | 7,6 | 8,3 | 9,1  | 9,9  |
| 7                    | 4,4               | 4,5 | 4,7 | 4,9 | 5,1 | 5,3 | 5,6 | 5,9 | 6,2 | 6,6 | 7,0 | 7,4 | 7,9 | 8,4 | 9,0 | 9,7  | 10,5 |
| 8                    | 5,4               | 5,5 | 5,7 | 5,9 | 6,1 | 6,3 | 6,6 | 6,8 | 7,1 | 7,5 | 7,9 | 8,3 | 8,7 | 9,2 | 9,8 | 10,4 | 11,1 |

\* Reveal adjustment - 2 mm / + 4 mm

# Intermat 9936 FIX

## Toolless fast-assembly for profile doors up to 32 mm

### Opening angle 95°

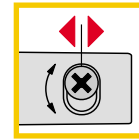
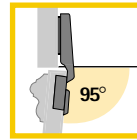
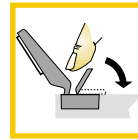

**Concealed hinge, snap-on assembly plus toolless cup assembly, integrated door overlay and eccentric depth adjustment.**

Opening angle 95°, cup diameter 35 mm.

The hinge enables an optimal reveal (hairline reveal) for profile doors.

For technical details of door contours, see page 3.50

Intermat 9936 FIX hinges are snapped onto the mounting plate and also feature toolless cup assembly.

Depth adjustment via eccentric screw -0,5 mm/+3,5 mm.

Height adjustment via mounting plate +2 mm/-2 mm, see pages 3.110 - 3.112.

#### Cup version

**Cup T FIX**  
Toolless  
Nickel-plated steel

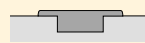

**Cup TH FIX**  
Toolless  
with pegs  
Nickel-plated steel

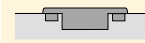

**Cup TB FIX**  
Toolless  
with pegs  
Nickel-plated steel

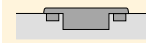

#### Hinge version

#### Mounting option

#### Article/order number

##### Intermat 9936 FIX

- self-closing

Packaging unit 50 pcs

● 9936-T FIX  
077 671

● 9936-TH FIX  
077 672

● 9936-TB FIX  
077 673

##### Door buffer Silent System

 clip-on

048 044

 screw-on

042 001

 drill-in

048 047



Full overlay

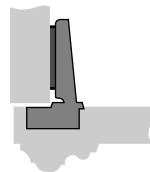

Half overlay

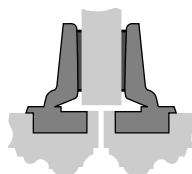

##### Intermat 9936 FIX

- self-closing

Packaging unit 50 pcs

● 9936-T FIX  
077 674

● 9936-TH FIX  
077 675

● 9936-TB FIX  
077 676

##### Door buffer Silent System

 clip-on

048 045

 screw-on

042 001

 drill-in

048 047



Inset

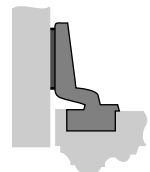

##### Intermat 9936 FIX

- self-closing

Packaging unit 50 pcs

● 9936-T FIX  
077 677

● 9936-TH FIX  
077 678

● 9936-TB FIX  
077 679

##### Door buffer Silent System

 clip-on

048 046

 screw-on

048 048

## Specification

Hettich Intermat 9936 FIX  
 Snap-on assembly plus toolless cup assembly  
 Eccentric depth adjustment  
 for door thickness up to 32 mm  
 Opening angle 95°

### Cover cap for Intermat hinges

Nickel-plated steel  
**Order no. 013 300**  
 Black plastic  
**Order no. 048 043**  
 PU = 50 pcs



| Cup distance<br>C mm | Door thickness mm  |     |     |     |     |     |     |     |     |     |     |     |     |     |     |     |     |
|----------------------|--|-----|-----|-----|-----|-----|-----|-----|-----|-----|-----|-----|-----|-----|-----|-----|-----|
|                      | 16   | 17  | 18  | 19  | 20  | 21  | 22  | 23  | 24  | 25  | 26  | 27  | 28  | 29  | 30  | 31  | 32  |
|                      | <b>Minimum reveal per door – allow for in distance calculation</b> |     |     |     |     |     |     |     |     |     |     |     |     |     |     |     |     |
|                      | Table entries apply to doors with 0 mm radius                      |     |     |     |     |     |     |     |     |     |     |     |     |     |     |     |     |
| 3                    | 0,4  | 0,6 | 0,8 | 1,0 | 1,2 | 1,5 | 1,8 | 2,1 | 2,5 | 2,9 | 3,4 | 4,0 | 4,9 | 5,7 | 6,6 | 7,5 | 8,4 |
| 4                    | 0,4  | 0,6 | 0,8 | 1,0 | 1,2 | 1,5 | 1,8 | 2,1 | 2,5 | 2,8 | 3,3 | 3,8 | 4,5 | 5,3 | 6,1 | 7,0 | 7,9 |
| 4,5                  | 0,4  | 0,6 | 0,8 | 1,0 | 1,2 | 1,5 | 1,8 | 2,1 | 2,5 | 2,7 | 3,2 | 3,7 | 4,4 | 5,1 | 5,9 | 6,7 | 7,6 |
| 5                    | 0,4  | 0,6 | 0,8 | 1,0 | 1,2 | 1,4 | 1,7 | 2,0 | 2,4 | 2,7 | 3,2 | 3,6 | 4,2 | 4,9 | 5,7 | 6,5 | 7,4 |
| 6                    | 0,4  | 0,6 | 0,8 | 1,0 | 1,2 | 1,4 | 1,7 | 2,0 | 2,3 | 2,6 | 3,1 | 3,5 | 4,0 | 4,6 | 5,3 | 6,1 | 6,9 |
| 7                    | 0,4  | 0,5 | 0,7 | 0,9 | 1,1 | 1,3 | 1,6 | 1,9 | 2,2 | 2,6 | 3,0 | 3,4 | 3,9 | 4,4 | 5,0 | 5,7 | 6,5 |
| 8                    | 0,4  | 0,5 | 0,7 | 0,9 | 1,1 | 1,3 | 1,6 | 1,8 | 2,1 | 2,5 | 2,9 | 3,3 | 3,7 | 4,2 | 4,8 | 5,4 | 6,1 |

The minimum reveal is reduced for doors with radii: 1 mm radius: table entry – 0,4 mm  
 3 mm radius: table entry – 1,2 mm

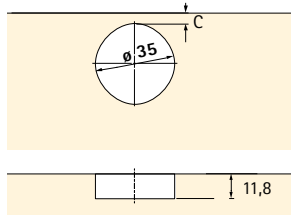

T FIX hole dimensions

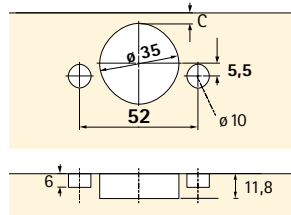

TH FIX hole dimensions

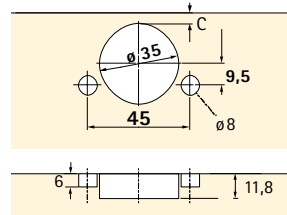

TB FIX hole dimensions

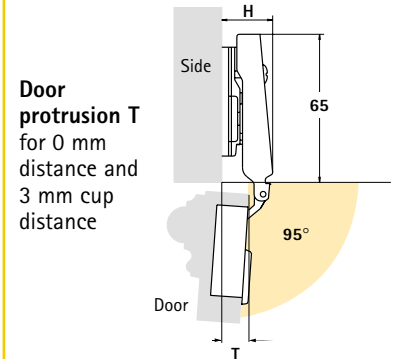

Door protrusion T for 0 mm distance and 3 mm cup distance

| Cranking mm | H mm | T mm |
|-------------|------|------|
| 0           | 18,5 | 10   |
| 9,5         | 28   | 19,5 |
| 16          | 34,5 | 26   |

3

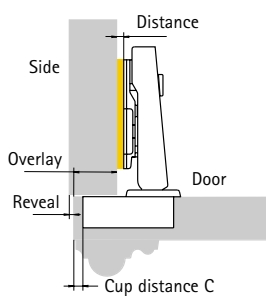

| Cup distance<br>C mm | Overlay mm           |      |     |     |     |     |     |     |     |     |     |     |
|----------------------|----------------------|------|-----|-----|-----|-----|-----|-----|-----|-----|-----|-----|
|                      | 10                   | 11   | 12  | 13  | 14  | 15  | 16  | 17  | 18  | 19  | 20  | 21  |
|                      | <b>Distance D mm</b> |      |     |     |     |     |     |     |     |     |     |     |
| 3                    | 6,0                  | 5,0  | 4,0 | 3,0 | 2,0 | 1,0 | 0,0 |     |     |     |     |     |
| 4                    | 7,0                  | 6,0  | 5,0 | 4,0 | 3,0 | 2,0 | 1,0 | 0,0 |     |     |     |     |
| 4,5                  | 7,5                  | 6,5  | 5,5 | 4,5 | 3,5 | 2,5 | 1,5 | 0,5 |     |     |     |     |
| 5                    | 8,0                  | 7,0  | 6,0 | 5,0 | 4,0 | 3,0 | 2,0 | 1,0 | 0,0 |     |     |     |
| 6                    | 9,0                  | 8,0  | 7,0 | 6,0 | 5,0 | 4,0 | 3,0 | 2,0 | 1,0 | 0,0 |     |     |
| 7                    | 10,0                 | 9,0  | 8,0 | 7,0 | 6,0 | 5,0 | 4,0 | 3,0 | 2,0 | 1,0 | 0,0 |     |
| 8                    | 11,0                 | 10,0 | 9,0 | 8,0 | 7,0 | 6,0 | 5,0 | 4,0 | 3,0 | 2,0 | 1,0 | 0,0 |

\* Overlay adjustment + 2 mm / - 4 mm

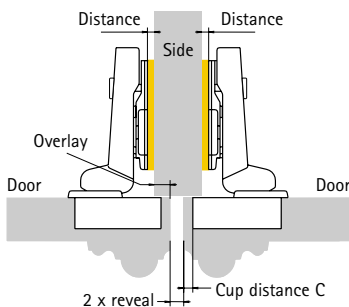

| Cup distance<br>C mm | Overlay mm           |      |     |     |     |     |     |     |     |     |     |     |
|----------------------|----------------------|------|-----|-----|-----|-----|-----|-----|-----|-----|-----|-----|
|                      | 0                    | 1    | 2   | 3   | 4   | 5   | 6   | 7   | 8   | 9   | 10  | 11  |
|                      | <b>Distance D mm</b> |      |     |     |     |     |     |     |     |     |     |     |
| 3                    | 6,5                  | 5,5  | 4,5 | 3,5 | 2,5 | 1,5 | 0,5 |     |     |     |     |     |
| 4                    | 7,5                  | 6,5  | 5,5 | 4,5 | 3,5 | 2,5 | 1,5 | 0,5 |     |     |     |     |
| 4,5                  | 8,0                  | 7,0  | 6,0 | 5,0 | 4,0 | 3,0 | 2,0 | 1,0 | 0,0 |     |     |     |
| 5                    | 8,5                  | 7,5  | 6,5 | 5,5 | 4,5 | 3,5 | 2,5 | 1,5 | 0,5 |     |     |     |
| 6                    | 9,5                  | 8,5  | 7,5 | 6,5 | 5,5 | 4,5 | 3,5 | 2,5 | 1,5 | 0,5 |     |     |
| 7                    | 10,5                 | 9,5  | 8,5 | 7,5 | 6,5 | 5,5 | 4,5 | 3,5 | 2,5 | 1,5 | 0,5 |     |
| 8                    | 11,5                 | 10,5 | 9,5 | 8,5 | 7,5 | 6,5 | 5,5 | 4,5 | 3,5 | 2,5 | 1,5 | 0,5 |

\* Overlay adjustment + 2 mm / - 4 mm

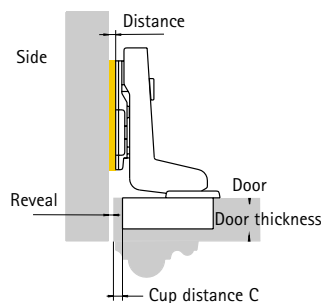

| Cup distance<br>C mm | Door thickness mm    |     |     |     |     |     |     |     |     |     |     |     |     |     |     |      |      |
|----------------------|----------------------|-----|-----|-----|-----|-----|-----|-----|-----|-----|-----|-----|-----|-----|-----|------|------|
|                      | 16                   | 17  | 18  | 19  | 20  | 21  | 22  | 23  | 24  | 25  | 26  | 27  | 28  | 29  | 30  | 31   | 32   |
|                      | <b>Distance D mm</b> |     |     |     |     |     |     |     |     |     |     |     |     |     |     |      |      |
| 3                    | 0,4                  | 0,6 | 0,8 | 1,0 | 1,2 | 1,5 | 1,8 | 2,1 | 2,5 | 2,9 | 3,4 | 4,0 | 4,9 | 5,7 | 6,6 | 7,5  | 8,4  |
| 4                    | 1,4                  | 1,6 | 1,8 | 2,0 | 2,2 | 2,5 | 2,8 | 3,1 | 3,5 | 3,8 | 4,3 | 4,8 | 5,5 | 6,3 | 7,1 | 8,0  | 8,9  |
| 4,5                  | 1,9                  | 2,1 | 2,3 | 2,5 | 2,7 | 3,0 | 3,3 | 3,6 | 4,0 | 4,3 | 4,8 | 5,2 | 5,9 | 6,6 | 7,4 | 8,3  | 9,2  |
| 5                    | 2,4                  | 2,6 | 2,8 | 3,0 | 3,2 | 3,4 | 3,7 | 4,0 | 4,4 | 4,7 | 5,2 | 5,6 | 6,2 | 6,9 | 7,7 | 8,5  | 9,4  |
| 6                    | 3,4                  | 3,6 | 3,8 | 4,0 | 4,2 | 4,4 | 4,7 | 5,0 | 5,3 | 5,6 | 6,1 | 6,5 | 7,0 | 7,6 | 8,3 | 9,1  | 9,9  |
| 7                    | 4,4                  | 4,5 | 4,7 | 4,9 | 5,1 | 5,3 | 5,6 | 5,9 | 6,2 | 6,6 | 7,0 | 7,4 | 7,9 | 8,4 | 9,0 | 9,7  | 10,5 |
| 8                    | 5,4                  | 5,5 | 5,7 | 5,9 | 6,1 | 6,3 | 6,6 | 6,8 | 7,1 | 7,5 | 7,9 | 8,3 | 8,7 | 9,2 | 9,8 | 10,4 | 11,1 |

\* Reveal adjustment - 2 mm / + 4 mm

# Door contours for hairline reveal with Intermat 9936 / 9936 FIX



The entries in the table for "minimum door reveal" refer to door edges with sharp corners.

Reveal values improve when door edges are rounded.

For a hair line reveal, the selected door contour must lie inside the maximum possible door contour based on the cup distance. All contours protruding over the template will increase the reveal correspondingly.

3

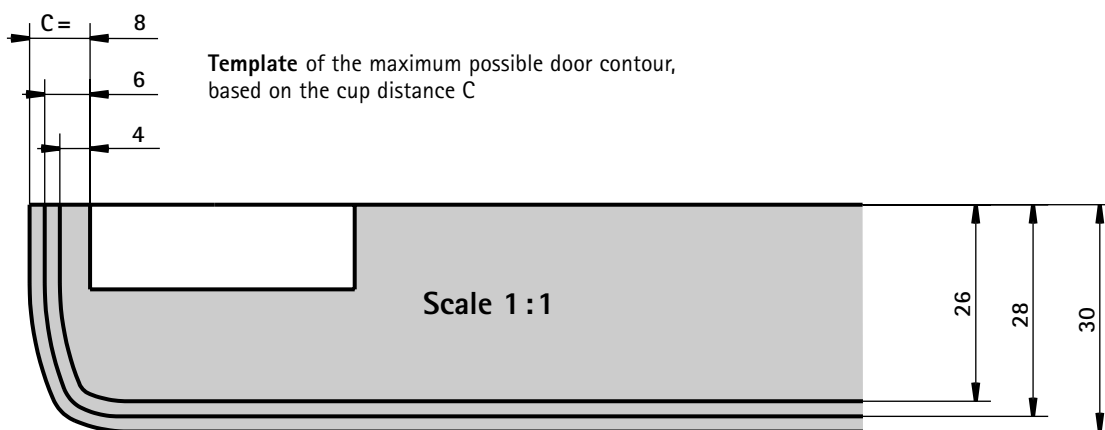

## Example

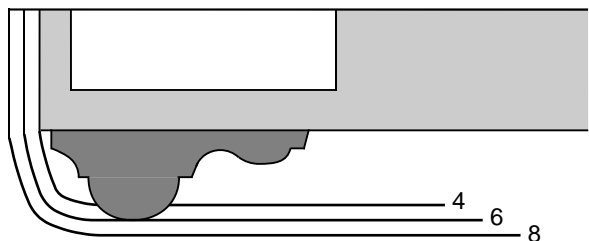

### Example for hairline reveal

|                   |       |
|-------------------|-------|
| Door thickness    | 16 mm |
| Profile thickness | 12 mm |
| Total thickness   | 28 mm |
| Cup distance C    | 6 mm  |

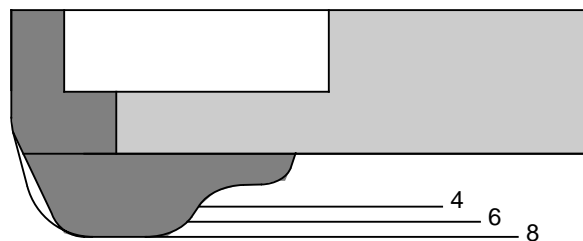

### Example for hairline reveal

|                   |       |
|-------------------|-------|
| Door thickness    | 19 mm |
| Profile thickness | 11 mm |
| Total thickness   | 30 mm |
| Cup distance C    | 8 mm  |

# Door contours for hairline reveal with Intermat 9935



The entries in the table for "minimum door reveal" refer to door edges with sharp corners.

Reveal values improve when door edges are rounded.

For a hair line reveal, the selected door contour must lie inside the maximum possible door contour based on the cup distance. All contours protruding over the template will increase the reveal correspondingly.

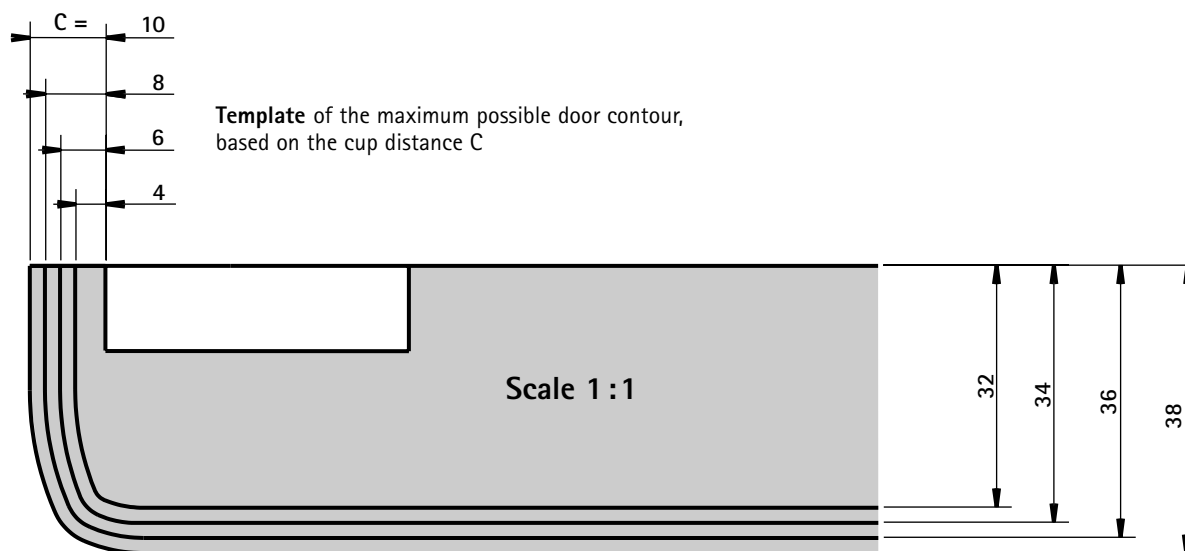

3

## Example

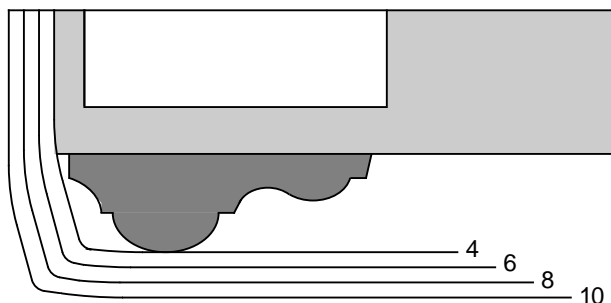

### Example for hairline reveal

|                   |       |
|-------------------|-------|
| Door thickness    | 19 mm |
| Profile thickness | 13 mm |
| Total thickness   | 32 mm |
| Cup distance C    | 4 mm  |

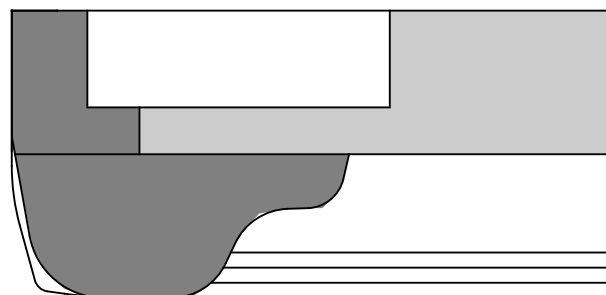

### Example for hairline reveal

|                   |       |
|-------------------|-------|
| Door thickness    | 19 mm |
| Profile thickness | 19 mm |
| Total thickness   | 38 mm |
| Cup distance C    | 10 mm |

# Intermat 9935

## Fast-assembly hinge for profile doors up to 43 mm

### Opening angle 95°

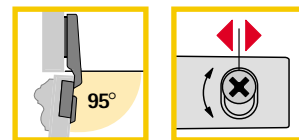

**Concealed hinges, snap-on assembly, integrated door overlay and eccentric depth adjustment.**

Opening angle 95°, cup diameter 40 mm,

The hinge enables an optimal reveal (hairline reveal) for profile doors.

For technical details of door contours, see page 3.51.

Intermat 9935 hinges are snapped onto the mounting plate.

Depth adjustment via eccentric screw -0,5 mm/+3,5 mm.

Height adjustment via mounting plate +2 mm/-2 mm, see pages 3.110 – 3.112.

Cup fixing screw  $\varnothing$  3,5 x 13 mm nickel-plated, for cup T 22/40

Order no. 048 296, PU 200

#### Cup version

##### Cup T 22 / 40

Screw-on  
Nickel-plated  
die-cast zinc

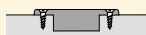

#### Hinge version

Cranking - 5 mm



#### Mounting option

Full overlay

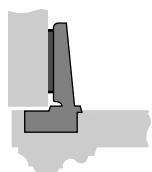

#### Article/order number

##### Intermat 9935

● self-closing

PU 10 pcs

● 9935-T22/40

073 925

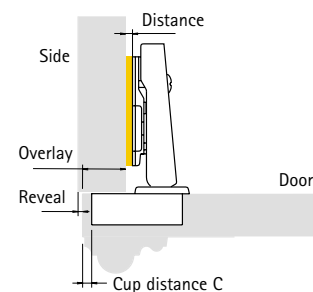

Cranking 5 mm



Half overlay

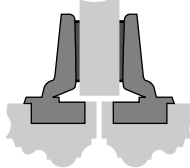

##### Intermat 9935

● self-closing

PU 10 pcs

● 9935-T22/40

073 926

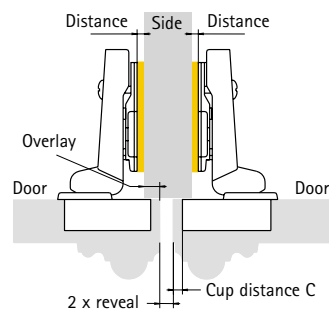

Cranking 16 mm



Inset

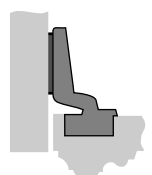

##### Intermat 9935

● self-closing

PU 10 pcs

● 9935-T22/40

073 927

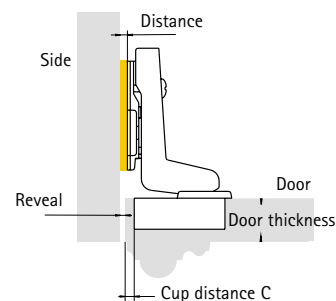

## Specification

Hettich Intermat 9935  
Snap-on assembly  
Eccentric depth adjustment  
for door thickness up to 43 mm  
Opening angle 95°

### Cover cap for Intermat hinges

Nickel-plated steel  
**Order no. 013 300**  
Black plastic  
**Order no. 048 043**  
PU = 50 pcs



| Cup distance<br>C mm   | Door thickness mm |    |     |     |     |     |     |     |     |     |     |     |     |     |     |     |     |     |     |     |     |     |     |     |     |      |      |      |  |  |  |  |  |  |  |  |  |  |  |  |  |  |
|--|-------------------|----|-----|-----|-----|-----|-----|-----|-----|-----|-----|-----|-----|-----|-----|-----|-----|-----|-----|-----|-----|-----|-----|-----|-----|------|------|------|--|--|--|--|--|--|--|--|--|--|--|--|--|--|
|  | 16                | 17 | 18  | 19  | 20  | 21  | 22  | 23  | 24  | 25  | 26  | 27  | 28  | 29  | 30  | 31  | 32  | 33  | 34  | 35  | 36  | 37  | 38  | 39  | 40  | 41   | 42   | 43   |  |  |  |  |  |  |  |  |  |  |  |  |  |  |
| <b>Minimum reveal per door – allow for in distance calculation</b> |                   |    |     |     |     |     |     |     |     |     |     |     |     |     |     |     |     |     |     |     |     |     |     |     |     |      |      |      |  |  |  |  |  |  |  |  |  |  |  |  |  |  |
| Table entries apply to doors with 0 mm radius                      |                   |    |     |     |     |     |     |     |     |     |     |     |     |     |     |     |     |     |     |     |     |     |     |     |     |      |      |      |  |  |  |  |  |  |  |  |  |  |  |  |  |  |
| 3  | 0                 | 0  | 0,1 | 0,2 | 0,3 | 0,4 | 0,5 | 0,6 | 0,7 | 0,9 | 1,1 | 1,3 | 1,5 | 1,7 | 1,9 | 2,1 | 2,4 | 3,2 | 4,1 | 4,9 | 5,8 | 6,8 | 7,8 | 8,8 | 9,7 | 10,7 | 11,7 | 12,6 |  |  |  |  |  |  |  |  |  |  |  |  |  |  |
| 4  | 0                 | 0  | 0,1 | 0,2 | 0,3 | 0,4 | 0,5 | 0,6 | 0,7 | 0,9 | 1,1 | 1,3 | 1,5 | 1,7 | 1,9 | 2,1 | 2,4 | 2,9 | 3,4 | 3,9 | 4,5 | 5,6 | 6,7 | 7,8 | 9,0 | 10,0 | 11,0 | 11,9 |  |  |  |  |  |  |  |  |  |  |  |  |  |  |
| 4,5  | 0                 | 0  | 0,1 | 0,2 | 0,3 | 0,4 | 0,5 | 0,6 | 0,7 | 0,9 | 1,1 | 1,3 | 1,5 | 1,7 | 1,9 | 2,1 | 2,4 | 2,9 | 3,4 | 3,9 | 4,3 | 5,4 | 6,5 | 7,5 | 8,7 | 9,7  | 10,6 | 11,6 |  |  |  |  |  |  |  |  |  |  |  |  |  |  |
| 5  | 0                 | 0  | 0,1 | 0,2 | 0,3 | 0,4 | 0,5 | 0,6 | 0,7 | 0,9 | 1,1 | 1,3 | 1,5 | 1,7 | 1,9 | 2,1 | 2,4 | 2,8 | 3,2 | 3,6 | 4,1 | 5,1 | 6,2 | 7,2 | 8,3 | 9,3  | 10,3 | 11,2 |  |  |  |  |  |  |  |  |  |  |  |  |  |  |
| 6  | 0                 | 0  | 0,1 | 0,2 | 0,3 | 0,4 | 0,5 | 0,6 | 0,7 | 0,9 | 1,1 | 1,3 | 1,5 | 1,7 | 1,9 | 2,1 | 2,4 | 2,8 | 3,2 | 3,6 | 3,9 | 4,8 | 5,8 | 6,7 | 7,7 | 8,7  | 9,7  | 10,6 |  |  |  |  |  |  |  |  |  |  |  |  |  |  |
| 7  | 0                 | 0  | 0,1 | 0,2 | 0,3 | 0,4 | 0,5 | 0,6 | 0,7 | 0,8 | 1,0 | 1,2 | 1,4 | 1,6 | 1,8 | 2,0 | 2,3 | 2,7 | 3,0 | 3,4 | 3,7 | 4,5 | 5,4 | 6,2 | 7,1 | 8,0  | 8,9  | 9,9  |  |  |  |  |  |  |  |  |  |  |  |  |  |  |
| 8  | 0                 | 0  | 0,1 | 0,2 | 0,3 | 0,4 | 0,5 | 0,6 | 0,7 | 0,8 | 1,0 | 1,2 | 1,4 | 1,6 | 1,8 | 2,0 | 2,3 | 2,6 | 2,9 | 3,2 | 3,5 | 4,2 | 4,9 | 5,6 | 6,4 | 7,3  | 8,2  | 9,1  |  |  |  |  |  |  |  |  |  |  |  |  |  |  |
| 9  | 0                 | 0  | 0,1 | 0,2 | 0,3 | 0,4 | 0,5 | 0,6 | 0,7 | 0,8 | 1,0 | 1,2 | 1,4 | 1,6 | 1,8 | 2,0 | 2,3 | 2,6 | 2,9 | 3,2 | 3,4 | 4,0 | 4,6 | 5,2 | 5,9 | 6,8  | 7,7  | 8,5  |  |  |  |  |  |  |  |  |  |  |  |  |  |  |
| 10   | 0                 | 0  | 0,1 | 0,2 | 0,3 | 0,4 | 0,5 | 0,6 | 0,7 | 0,8 | 1,0 | 1,2 | 1,4 | 1,6 | 1,8 | 2,0 | 2,3 | 2,6 | 2,8 | 3,1 | 3,3 | 3,8 | 4,3 | 4,8 | 5,3 | 6,2  | 7,1  | 7,9  |  |  |  |  |  |  |  |  |  |  |  |  |  |  |
| 11   | 0                 | 0  | 0,1 | 0,2 | 0,3 | 0,4 | 0,5 | 0,6 | 0,7 | 0,8 | 1,0 | 1,2 | 1,3 | 1,5 | 1,7 | 1,9 | 2,2 | 2,4 | 2,6 | 2,8 | 3,1 | 3,5 | 3,9 | 4,3 | 4,7 | 5,4  | 6,1  | 6,9  |  |  |  |  |  |  |  |  |  |  |  |  |  |  |

The minimum reveal is reduced for doors with radii: 1 mm radius: table entry – 0,4 mm / 3 mm radius: table entry – 1,2 mm

### T 22 / 40 hole dimensions

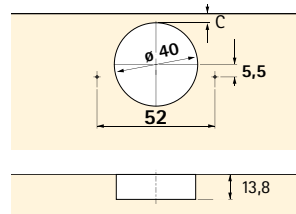

### Door protrusion T

for 0 mm distance and 3 mm cup distance

| Cranking<br>mm | H<br>mm | T<br>mm |
|----------------|---------|---------|
| - 5            | 20      | 10,5    |
| 5              | 30      | 20,5    |
| 16             | 41      | 31,5    |

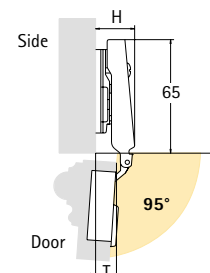

| Cup distance<br>C mm | Overlay mm |      |      |      |      |      |      |      |     |     |     |     |     |     |     |     |     |     |  |
|----------------------|------------|------|------|------|------|------|------|------|-----|-----|-----|-----|-----|-----|-----|-----|-----|-----|--|
|                      | 12         | 13   | 14   | 15   | 16   | 17   | 18   | 19   | 20  | 21  | 22  | 23  | 24  | 25  | 26  | 27  | 28  | 29  |  |
| <b>Distance D mm</b> |            |      |      |      |      |      |      |      |     |     |     |     |     |     |     |     |     |     |  |
| 3                    | 9,0        | 8,0  | 7,0  | 6,0  | 5,0  | 4,0  | 3,0  | 2,0  | 1,0 | 0,0 |     |     |     |     |     |     |     |     |  |
| 4                    | 10,0       | 9,0  | 8,0  | 7,0  | 6,0  | 5,0  | 4,0  | 3,0  | 2,0 | 1,0 | 0,0 |     |     |     |     |     |     |     |  |
| 4,5                  | 10,5       | 9,5  | 8,5  | 7,5  | 6,5  | 5,5  | 4,5  | 3,5  | 2,5 | 1,5 | 0,5 |     |     |     |     |     |     |     |  |
| 5                    | 11,0       | 10,0 | 9,0  | 8,0  | 7,0  | 6,0  | 5,0  | 4,0  | 3,0 | 2,0 | 1,0 | 0,0 |     |     |     |     |     |     |  |
| 6                    | 12,0       | 11,0 | 10,0 | 9,0  | 8,0  | 7,0  | 6,0  | 5,0  | 4,0 | 3,0 | 2,0 | 1,0 | 0,0 |     |     |     |     |     |  |
| 7                    | 13,0       | 12,0 | 11,0 | 10,0 | 9,0  | 8,0  | 7,0  | 6,0  | 5,0 | 4,0 | 3,0 | 2,0 | 1,0 | 0,0 |     |     |     |     |  |
| 8                    | 14,0       | 13,0 | 12,0 | 11,0 | 10,0 | 9,0  | 8,0  | 7,0  | 6,0 | 5,0 | 4,0 | 3,0 | 2,0 | 1,0 | 0,0 |     |     |     |  |
| 9                    | 15,0       | 14,0 | 13,0 | 12,0 | 11,0 | 10,0 | 9,0  | 8,0  | 7,0 | 6,0 | 5,0 | 4,0 | 3,0 | 2,0 | 1,0 | 0,0 |     |     |  |
| 10                   | 16,0       | 15,0 | 14,0 | 13,0 | 12,0 | 11,0 | 10,0 | 9,0  | 8,0 | 7,0 | 6,0 | 5,0 | 4,0 | 3,0 | 2,0 | 1,0 | 0,0 |     |  |
| 11                   | 17,0       | 16,0 | 15,0 | 14,0 | 13,0 | 12,0 | 11,0 | 10,0 | 9,0 | 8,0 | 7,0 | 6,0 | 5,0 | 4,0 | 3,0 | 2,0 | 1,0 | 0,0 |  |

\* Overlay adjustment – 4 mm, + 0,5 mm

| Cup distance<br>C mm | Overlay mm |      |      |      |      |      |      |      |      |      |     |     |     |     |     |     |     |     |     |     |
|----------------------|------------|------|------|------|------|------|------|------|------|------|-----|-----|-----|-----|-----|-----|-----|-----|-----|-----|
|                      | 0          | 1    | 2    | 3    | 4    | 5    | 6    | 7    | 8    | 9    | 10  | 11  | 12  | 13  | 14  | 15  | 16  | 17  | 18  | 19  |
| <b>Distance D mm</b> |            |      |      |      |      |      |      |      |      |      |     |     |     |     |     |     |     |     |     |     |
| 3                    | 11,0       | 10,0 | 9,0  | 8,0  | 7,0  | 6,0  | 5,0  | 4,0  | 3,0  | 2,0  | 1,0 | 0,0 |     |     |     |     |     |     |     |     |
| 4                    | 12,0       | 11,0 | 10,0 | 9,0  | 8,0  | 7,0  | 6,0  | 5,0  | 4,0  | 3,0  | 2,0 | 1,0 | 0,0 |     |     |     |     |     |     |     |
| 4,5                  | 12,5       | 11,5 | 10,5 | 9,5  | 8,5  | 7,5  | 6,5  | 5,5  | 4,5  | 3,5  | 2,5 | 1,5 | 0,5 |     |     |     |     |     |     |     |
| 5                    | 13,0       | 12,0 | 11,0 | 10,0 | 9,0  | 8,0  | 7,0  | 6,0  | 5,0  | 4,0  | 3,0 | 2,0 | 1,0 | 0,0 |     |     |     |     |     |     |
| 6                    | 14,0       | 13,0 | 12,0 | 11,0 | 10,0 | 9,0  | 8,0  | 7,0  | 6,0  | 5,0  | 4,0 | 3,0 | 2,0 | 1,0 | 0,0 |     |     |     |     |     |
| 7                    | 15,0       | 14,0 | 13,0 | 12,0 | 11,0 | 10,0 | 9,0  | 8,0  | 7,0  | 6,0  | 5,0 | 4,0 | 3,0 | 2,0 | 1,0 | 0,0 |     |     |     |     |
| 8                    | 16,0       | 15,0 | 14,0 | 13,0 | 12,0 | 11,0 | 10,0 | 9,0  | 8,0  | 7,0  | 6,0 | 5,0 | 4,0 | 3,0 | 2,0 | 1,0 | 0,0 |     |     |     |
| 9                    | 17,0       | 16,0 | 15,0 | 14,0 | 13,0 | 12,0 | 11,0 | 10,0 | 9,0  | 8,0  | 7,0 | 6,0 | 5,0 | 4,0 | 3,0 | 2,0 | 1,0 | 0,0 |     |     |
| 10                   | 18,0       | 17,0 | 16,0 | 15,0 | 14,0 | 13,0 | 12,0 | 11,0 | 10,0 | 9,0  | 8,0 | 7,0 | 6,0 | 5,0 | 4,0 | 3,0 | 2,0 | 1,0 | 0,0 |     |
| 11                   | 19,0       | 18,0 | 17,0 | 16,0 | 15,0 | 14,0 | 13,0 | 12,0 | 11,0 | 10,0 | 9,0 | 8,0 | 7,0 | 6,0 | 5,0 | 4,0 | 3,0 | 2,0 | 1,0 | 0,0 |

\* Overlay adjustment – 4 mm, + 0,5 mm

| Cup distance<br>C mm | Door thickness mm |     |     |     |     |     |     |     |     |     |     |     |     |     |     |     |      |      |      |      |      |      |      |      |      |      |      |      |  |  |  |  |  |  |  |  |  |  |  |  |  |  |
|----------------------|-------------------|-----|-----|-----|-----|-----|-----|-----|-----|-----|-----|-----|-----|-----|-----|-----|------|------|------|------|------|------|------|------|------|------|------|------|--|--|--|--|--|--|--|--|--|--|--|--|--|--|
|                      | 16                | 17  | 18  | 19  | 20  | 21  | 22  | 23  | 24  | 25  | 26  | 27  | 28  | 29  | 30  | 31  | 32   | 33   | 34   | 35   | 36   | 37   | 38   | 39   | 40   | 41   | 42   | 43   |  |  |  |  |  |  |  |  |  |  |  |  |  |  |
| <b>Distance D mm</b> |                   |     |     |     |     |     |     |     |     |     |     |     |     |     |     |     |      |      |      |      |      |      |      |      |      |      |      |      |  |  |  |  |  |  |  |  |  |  |  |  |  |  |
| 3                    |                   |     |     |     |     | 0,5 | 0,6 | 0,7 | 0,9 | 1,1 | 1,3 | 1,5 | 1,7 | 1,9 | 2,1 | 2,4 | 3,2  | 4,1  | 4,9  | 5,8  | 6,8  | 7,8  | 8,8  | 9,7  | 10,7 | 11,7 | 12,6 |      |  |  |  |  |  |  |  |  |  |  |  |  |  |  |
| 4                    | 1,0               | 1,0 | 1,1 | 1,2 | 1,3 | 1,4 | 1,5 | 1,6 | 1,7 | 1,9 | 2,1 | 2,3 | 2,5 | 2,7 | 2,9 | 3,1 | 3,4  | 3,9  | 4,4  | 4,9  | 5,8  | 6,8  | 7,8  | 8,8  | 9,7  | 10,7 | 11,7 | 12,6 |  |  |  |  |  |  |  |  |  |  |  |  |  |  |
| 4,5                  | 1,5               | 1,5 | 1,6 | 1,7 | 1,8 | 1,9 | 2,0 | 2,1 | 2,2 | 2,4 | 2,6 | 2,8 | 3,0 | 3,2 | 3,4 | 3,6 | 3,9  | 4,4  | 4,9  | 5,4  | 5,5  | 6,6  | 7,7  | 8,8  | 10,0 | 11,0 | 12,0 | 12,9 |  |  |  |  |  |  |  |  |  |  |  |  |  |  |
| 5                    | 2,0               | 2,0 | 2,1 | 2,3 | 2,3 | 2,4 | 2,5 | 2,6 | 2,7 | 2,9 | 3,1 | 3,3 | 3,5 | 3,7 | 3,9 | 4,1 | 4,4  | 4,8  | 5,2  | 5,6  | 5,8  | 6,9  | 8,0  | 9,1  | 10,1 | 11,1 | 12,1 | 13,0 |  |  |  |  |  |  |  |  |  |  |  |  |  |  |
| 6                    | 3,0               | 3,0 | 3,1 | 3,2 | 3,3 | 3,4 | 3,5 | 3,6 | 3,7 | 3,9 | 4,1 | 4,3 | 4,5 | 4,7 | 4,9 | 5,1 | 5,4  | 5,8  | 6,2  | 6,6  | 6,1  | 7,1  | 8,2  | 9,2  | 10,3 | 11,3 | 12,3 | 13,2 |  |  |  |  |  |  |  |  |  |  |  |  |  |  |
| 7                    | 4,0               | 4,0 | 4,1 | 4,2 | 4,3 | 4,4 | 4,5 | 4,6 | 4,7 | 4,8 | 5,0 | 5,2 | 5,4 | 5,6 | 5,8 | 6,0 | 6,3  | 6,7  | 7,0  | 7,4  | 6,9  | 7,8  | 8,8  | 9,7  | 10,7 | 11,7 | 12,7 | 13,6 |  |  |  |  |  |  |  |  |  |  |  |  |  |  |
| 8                    | 5,0               | 5,0 | 5,1 | 5,2 | 5,3 | 5,4 | 5,5 | 5,6 | 5,7 | 5,8 | 6,0 | 6,2 | 6,4 | 6,6 | 6,8 | 7,0 | 7,3  | 7,6  | 7,9  | 8,3  | 7,7  | 8,5  | 9,4  | 10,2 | 11,1 | 12,0 | 12,9 | 13,9 |  |  |  |  |  |  |  |  |  |  |  |  |  |  |
| 9                    | 6,0               | 6,0 | 6,1 | 6,2 | 6,3 | 6,4 | 6,5 | 6,6 | 6,7 | 6,8 | 7,0 | 7,2 | 7,4 | 7,6 | 7,8 | 8,0 | 8,3  | 8,6  | 8,9  | 9,2  | 8,5  | 9,2  | 9,9  | 10,6 | 11,4 | 12,3 | 13,2 | 14,1 |  |  |  |  |  |  |  |  |  |  |  |  |  |  |
| 10                   | 7,0               | 7,0 | 7,1 | 7,2 | 7,3 | 7,4 | 7,5 | 7,6 | 7,7 | 7,8 | 8,0 | 8,2 | 8,4 | 8,6 | 8,8 | 9,0 | 9,3  | 9,6  | 9,8  | 10,1 | 9,4  | 10,0 | 10,6 | 11,2 | 11,9 | 12,8 | 13,7 | 14,5 |  |  |  |  |  |  |  |  |  |  |  |  |  |  |
| 11                   | 8,0               | 8,0 | 8,1 | 8,2 | 8,3 | 8,4 | 8,5 | 8,6 | 8,7 | 8,8 | 9,0 | 9,2 | 9,3 | 9,5 | 9,7 | 9,9 | 10,2 | 10,4 | 10,6 | 10,8 | 10,3 | 10,8 | 11,3 | 11,8 | 12,3 | 13,2 | 14,1 | 14,9 |  |  |  |  |  |  |  |  |  |  |  |  |  |  |

\*Reveal adjustment + 4 mm, – 0,5 mm

# Intermat 9936 W20

## Fast-assembly hinge for corner cabinets

### Opening angle 95°

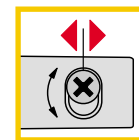
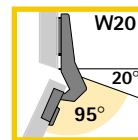

**Concealed hinge, snap-on assembly, integrated door overlay and eccentric depth adjustment.**

Opening angle 95°, cup diameter 35 mm.

Used for corner cupboards and cabinets with 20° face angle.

Interimat 9936 W20 hinges are snapped onto the mounting plate.

Depth adjustment via eccentric screw -0,5 mm/+3,5 mm.

Height adjustment via mounting plate +2 mm/-2 mm, see pages 3.110 - 3.112.

Cup fixing screw  $\varnothing$  3,5 x 13 mm nickel-plated, for cup T 42

Order no. 048 296, PU 200

#### Cup version

##### Cup T 42

Screw-on  
Nickel-plated  
steel

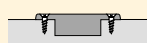

##### Cup T 43

Press-in  
Nickel-plated  
steel

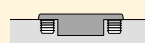

##### Cup TB 43

Press-in  
Nickel-plated  
steel

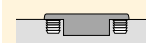

##### Cup Flash

Fast-assembly  
Nickel-plated  
steel

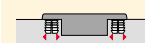

#### Hinge version

#### Mounting option

#### Article/order number

Cranking 7 mm



Full overlay

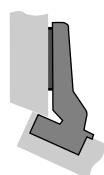

#### Interimat 9936 W20

● self-closing

Packaging unit 50 pcs

● 9936 W20-T42  
077 644

● 9936 W20-T43  
077 680

● 9936 W20-TB 43  
077 681

● 9936 W20-Flash  
079 300

#### Door buffer Silent System



screw-on

042 001



drill-in

048 047

Cranking - 9 mm



Inset

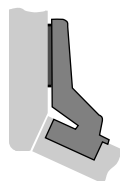

#### Interimat 9936 W20

● self-closing

Packaging unit 50 pcs

● 9936 W20-T42  
077 645

● 9936 W20-T43  
077 682

● 9936 W20-TB 43  
077 683

● 9936 W20-Flash  
079 301

#### Door buffer Silent System



screw-on

048 048

#### Mounting example Interimat 9936 W20 Full overlay

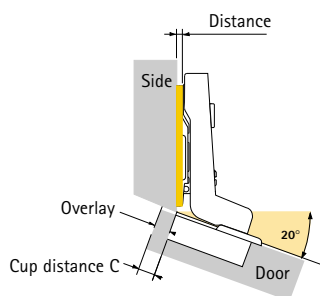

#### Mounting example Interimat 9936 W20 Inset

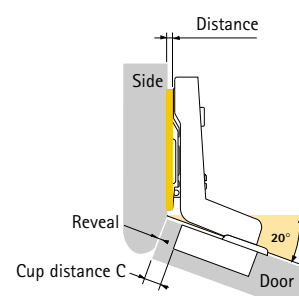

## Specification

Hettich Intermat 9936 W20  
 Snap-on assembly  
 Eccentric depth adjustment  
 for 20° face angle applications  
 Opening angle 95°

### Cover cap for Intermat hinges

Nickel-plated steel  
**Order no. 013 300**  
 Black plastic  
**Order no. 048 043**  
 PU = 50 pcs

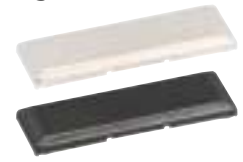

| Cup distance<br>C mm   | Door thickness mm |     |     |     |     |     |     |     |     |     |     |     |     |     |     |     |     |
|--|-------------------|-----|-----|-----|-----|-----|-----|-----|-----|-----|-----|-----|-----|-----|-----|-----|-----|
|  | 16                | 17  | 18  | 19  | 20  | 21  | 22  | 23  | 24  | 25  | 26  | 27  | 28  | 29  | 30  | 31  | 32  |
| <b>Minimum reveal per door – allow for in distance calculation</b> |                   |     |     |     |     |     |     |     |     |     |     |     |     |     |     |     |     |
| Table entries apply to doors with 0 mm radius                      |                   |     |     |     |     |     |     |     |     |     |     |     |     |     |     |     |     |
| 3  | 0,4               | 0,6 | 0,8 | 1,0 | 1,2 | 1,5 | 1,8 | 2,1 | 2,5 | 2,9 | 3,4 | 4,0 | 4,9 | 5,7 | 6,6 | 7,5 | 8,4 |
| 4  | 0,4               | 0,6 | 0,8 | 1,0 | 1,2 | 1,5 | 1,8 | 2,1 | 2,5 | 2,8 | 3,3 | 3,8 | 4,5 | 5,3 | 6,1 | 7,0 | 7,9 |
| 4,5  | 0,4               | 0,6 | 0,8 | 1,0 | 1,2 | 1,5 | 1,8 | 2,1 | 2,5 | 2,8 | 3,3 | 3,7 | 4,3 | 5,1 | 5,9 | 6,8 | 7,7 |
| 5  | 0,4               | 0,6 | 0,8 | 1,0 | 1,2 | 1,4 | 1,7 | 2,0 | 2,4 | 2,7 | 3,2 | 3,6 | 4,2 | 4,9 | 5,7 | 6,5 | 7,4 |
| 6  | 0,4               | 0,6 | 0,8 | 1,0 | 1,2 | 1,4 | 1,7 | 2,0 | 2,3 | 2,6 | 3,1 | 3,5 | 4,0 | 4,6 | 5,3 | 6,1 | 6,9 |
| 7  | 0,4               | 0,5 | 0,7 | 0,9 | 1,1 | 1,3 | 1,6 | 1,9 | 2,2 | 2,6 | 3,0 | 3,4 | 3,9 | 4,4 | 5,0 | 5,7 | 6,5 |
| 8  | 0,4               | 0,5 | 0,7 | 0,9 | 1,1 | 1,3 | 1,6 | 1,8 | 2,1 | 2,5 | 2,9 | 3,3 | 3,7 | 4,2 | 4,8 | 5,4 | 6,1 |

### Note:

Drawings on this page are to full scale and show the hinges plus mounting plate distances. By drawing in the required cup distance C (3–8 mm), the door overlay can be measured directly from the applicable distance line.

The distance from the **cabinet front edge to X** on the selected distance line is also equal to the hole line distance from the cabinet front edge.

For **inset-mounted** doors, the cup distance and door thickness must be taken into account when determining the **minimum reveal**.

The minimum reveal is reduced for doors with radii: 1 mm radius: table entry – 0,4 mm  
 3 mm radius: table entry – 1,2 mm

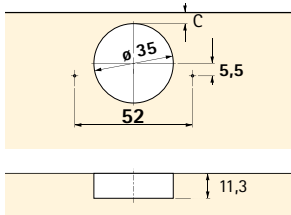

T42 hole dimensions

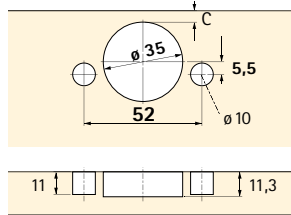

T43 / Flash hole dimensions

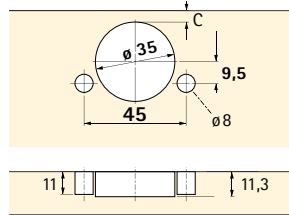

TB43 hole dimensions

### Full overlay

\* Overlay adjustment +2 mm / –4 mm

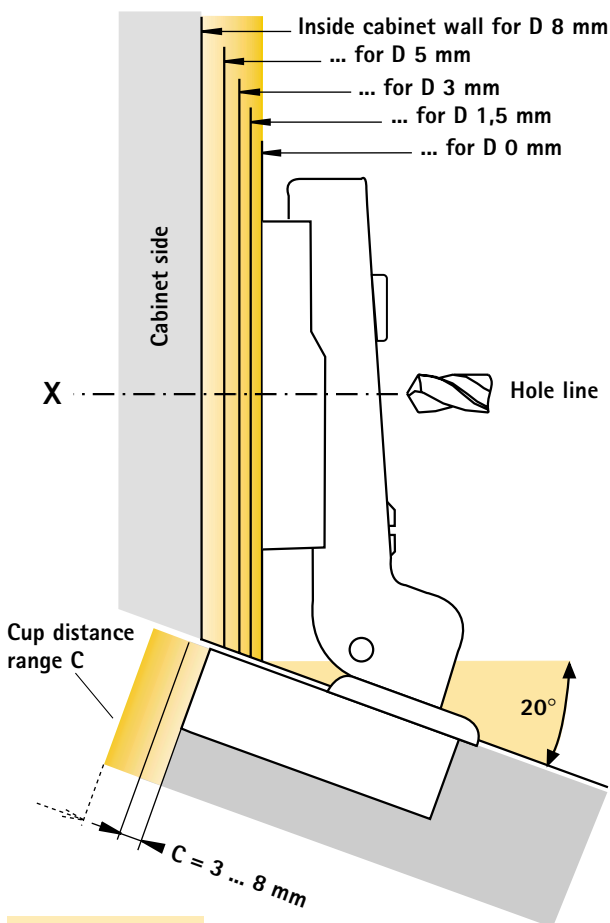

Scale 1:1

### Inset

\* Reveal adjustment –2 mm / +4 mm

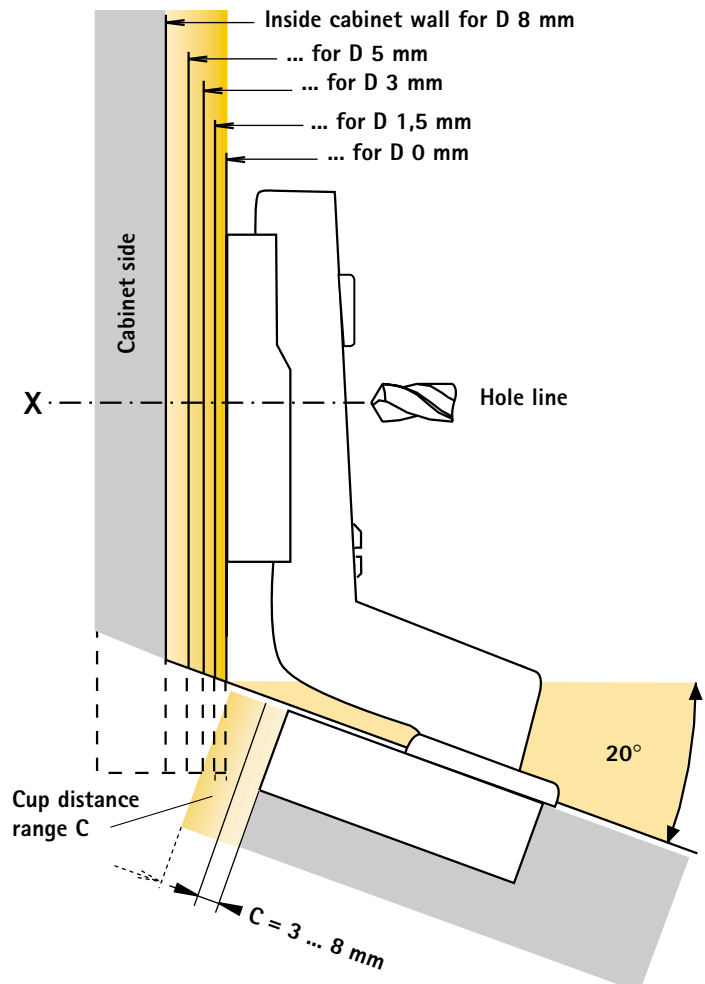

# Intermat 9936 W20 FIX

## Toolless fast-assembly for corner cabinets

### Opening angle 95°

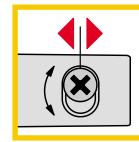
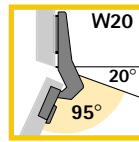
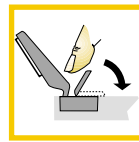

Concealed hinge, snap-on assembly and toolless cup assembly, integrated door overlay and eccentric depth adjustment.

Opening angle 95°, cup diameter 35 mm.

Used for corner cupboards and cabinets with 20° face angle.

Intermat 9936 W20 FIX hinges are snapped onto the mounting plate and also feature toolless cup assembly.

Depth adjustment via eccentric screw -0,5 mm/+3,5 mm.

Height adjustment via mounting plate +2 mm/-2 mm, see pages 3.110 - 3.112.

#### Cup version

**Cup T FIX**  
Toolless  
Nickel-plated steel

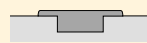

**Cup TH FIX**  
Toolless  
with pegs  
Nickel-plated steel

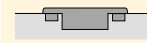

**Cup TB FIX**  
Toolless  
with pegs  
Nickel-plated steel

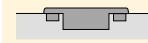

#### Hinge version

#### Mounting option

#### Article/order number

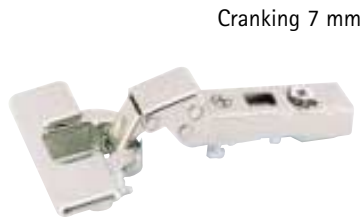

#### Full overlay

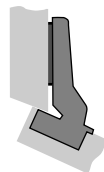

#### Intermat 9936 W20 FIX

- self-closing

Packaging unit 50 pcs

● 9936 W20-T FIX  
077 684

● 9936 W20-TH FIX  
077 685

● 9936 W20-TB FIX  
077 686

#### Door buffer Silent System



screw-on

042 001



drill-in

048 047



#### Inset

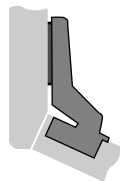

#### Intermat 9936 W20 FIX

- self-closing

Packaging unit 50 pcs

● 9936 W20-T FIX  
077 687

● 9936 W20-TH FIX  
077 688

● 9936 W20-TB FIX  
077 689

#### Door buffer Silent System



screw-on

048 048

#### Mounting example Intermat 9936 W20 FIX Full overlay

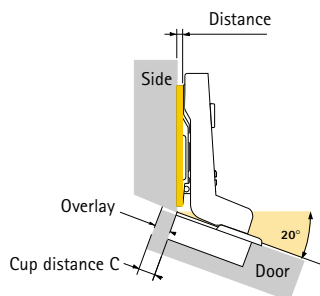

#### Mounting example Intermat 9936 W20 FIX Inset

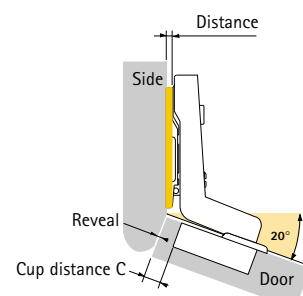

## Specification

Hettich Intermat 9936 W20 FIX  
 Snap-on assembly plus toolless cup assembly  
 Eccentric depth adjustment  
 for 20° face angle applications  
 Opening angle 95°

### Cover cap for Intermat hinges

Nickel-plated steel  
**Order no. 013 300**  
 Black plastic  
**Order no. 048 043**  
 PU = 50 pcs

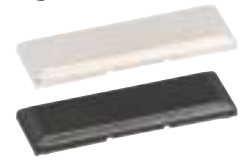

| Cup distance<br>C mm   | Door thickness mm |     |     |     |     |     |     |     |     |     |     |     |     |     |     |     |     |
|--|-------------------|-----|-----|-----|-----|-----|-----|-----|-----|-----|-----|-----|-----|-----|-----|-----|-----|
|  | 16                | 17  | 18  | 19  | 20  | 21  | 22  | 23  | 24  | 25  | 26  | 27  | 28  | 29  | 30  | 31  | 32  |
| <b>Minimum reveal per door – allow for in distance calculation</b> |                   |     |     |     |     |     |     |     |     |     |     |     |     |     |     |     |     |
| Table entries apply to doors with 0 mm radius                      |                   |     |     |     |     |     |     |     |     |     |     |     |     |     |     |     |     |
| 3  | 0,4               | 0,6 | 0,8 | 1,0 | 1,2 | 1,5 | 1,8 | 2,1 | 2,5 | 2,9 | 3,4 | 4,0 | 4,9 | 5,7 | 6,6 | 7,5 | 8,4 |
| 4  | 0,4               | 0,6 | 0,8 | 1,0 | 1,2 | 1,5 | 1,8 | 2,1 | 2,5 | 2,8 | 3,3 | 3,8 | 4,5 | 5,3 | 6,1 | 7,0 | 7,9 |
| 4,5  | 0,4               | 0,6 | 0,8 | 1,0 | 1,2 | 1,5 | 1,8 | 2,1 | 2,5 | 2,8 | 3,3 | 3,7 | 4,3 | 5,1 | 5,9 | 6,8 | 7,7 |
| 5  | 0,4               | 0,6 | 0,8 | 1,0 | 1,2 | 1,4 | 1,7 | 2,0 | 2,4 | 2,7 | 3,2 | 3,6 | 4,2 | 4,9 | 5,7 | 6,5 | 7,4 |
| 6  | 0,4               | 0,6 | 0,8 | 1,0 | 1,2 | 1,4 | 1,7 | 2,0 | 2,3 | 2,6 | 3,1 | 3,5 | 4,0 | 4,6 | 5,3 | 6,1 | 6,9 |
| 7  | 0,4               | 0,5 | 0,7 | 0,9 | 1,1 | 1,3 | 1,6 | 1,9 | 2,2 | 2,6 | 3,0 | 3,4 | 3,9 | 4,4 | 5,0 | 5,7 | 6,5 |
| 8  | 0,4               | 0,5 | 0,7 | 0,9 | 1,1 | 1,3 | 1,6 | 1,8 | 2,1 | 2,5 | 2,9 | 3,3 | 3,7 | 4,2 | 4,8 | 5,4 | 6,1 |

### Note:

Drawings on this page are to full scale and show the hinges plus mounting plate distances. By drawing in the required cup distance C (3–8 mm), the door overlay can be measured directly from the applicable distance line.

The distance from the **cabinet front edge to X** on the selected distance line is also equal to the hole line distance from the cabinet front edge.

For **inset-mounted** doors, the cup distance and door thickness must be taken into account when determining the **minimum reveal**.

The minimum reveal is reduced for doors with radii: 1 mm radius: table entry – 0,4 mm  
 3 mm radius: table entry – 1,2 mm

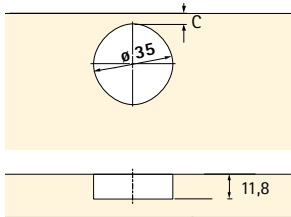

T FIX hole dimensions

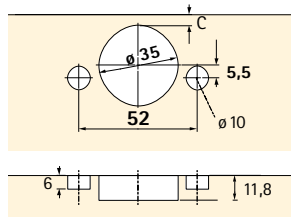

TH FIX hole dimensions

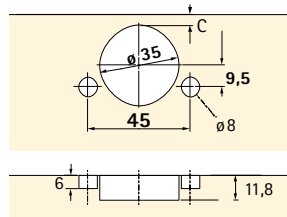

TB FIX hole dimensions

### Full overlay

\* Overlay adjustment +2 mm / –4 mm

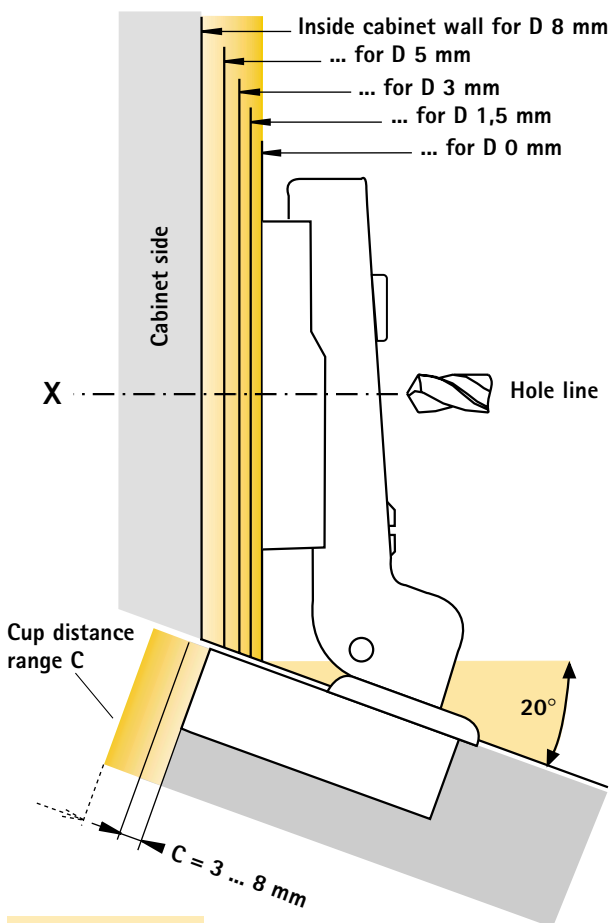

Scale 1:1

### Inset

\* Reveal adjustment –2 mm / +4 mm

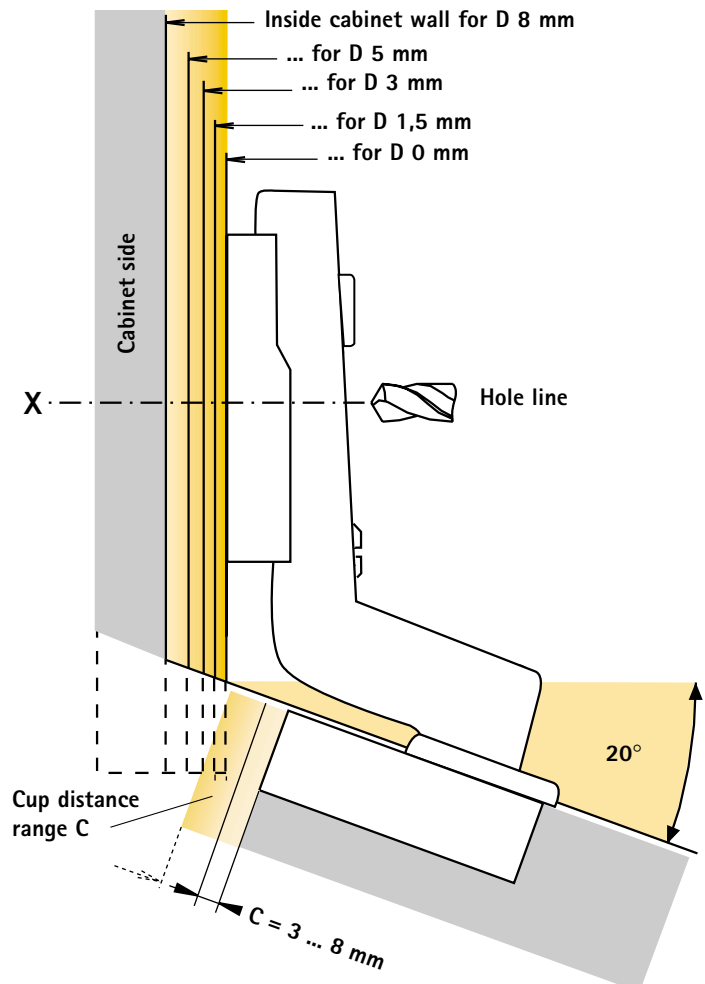

# Intermat 9936 W30

## Fast-assembly hinge for corner cabinets

### Opening angle 95°

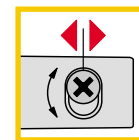
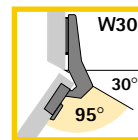

**Concealed hinge, snap-on assembly, integrated door overlay and eccentric depth adjustment.**

Opening angle 95°, cup diameter 35 mm.

For corner cupboards and cabinets with 30° face angle.

Interimat 9936 W30 hinges are snapped onto the mounting plate.

Depth adjustment via eccentric screw -0,5 mm/+3,5 mm.

Height adjustment via mounting plate +2 mm/-2 mm, see pages 3.110 - 3.112.

Cup fixing screw  $\varnothing$  3,5 x 13 mm nickel-plated, for cup T 42

Order no. 048 296, PU 200

#### Cup version

##### Cup T 42

Screw-on  
Nickel-plated  
steel

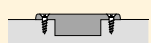

##### Cup T 43

Press-in  
Nickel-plated  
steel

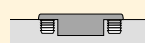

##### Cup TB 43

Press-in  
Nickel-plated  
steel

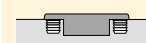

##### Cup Flash

Fast-assembly  
Nickel-plated  
steel

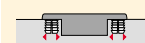

#### Hinge version



Cranking 7 mm

#### Mounting option

Full overlay

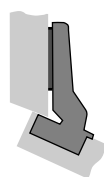

#### Article/order number

##### Interimat 9936 W30

● self-closing

Packaging unit 50 pcs

● 9936 W30-T42  
077 690

● 9936 W30-T43  
077 691

● 9936 W30-TB 43  
077 692

● 9936 W30-Flash  
079 302

##### Door buffer Silent System



screw-on

042 001



drill-in

048 047



Cranking - 10 mm

Inset

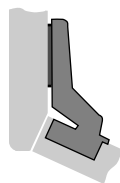

##### Interimat 9936 W30

● self-closing

Packaging unit 50 pcs

● 9936 W30-T42  
073 928

● 9936 W30-T43  
073 929

● 9936 W30-TB 43  
073 930

● 9936 W30-Flash  
073 931

##### Door buffer Silent System



screw-on

048 048

#### Mounting example Interimat 9936 W30 Full overlay

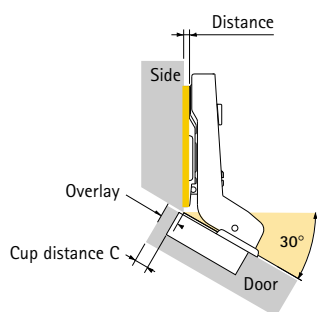

#### Mounting example Interimat 9936 W30 Inset

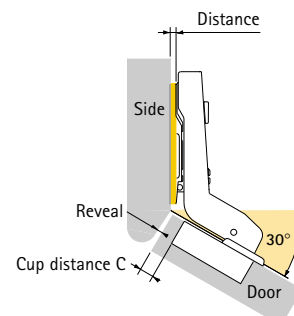

## Specification

Hettich Intermat 9936 W30  
 Snap-on assembly  
 Eccentric depth adjustment  
 for 30° face angle applications  
 Opening angle 95°

### Cover cap for Intermat hinges

Nickel-plated steel  
**Order no. 013 300**  
 Black plastic  
**Order no. 048 043**  
 PU = 50 pcs



| Cup distance<br>C mm   | Door thickness mm |     |     |     |     |     |     |     |     |     |     |     |     |     |     |     |     |
|--|-------------------|-----|-----|-----|-----|-----|-----|-----|-----|-----|-----|-----|-----|-----|-----|-----|-----|
|  | 16                | 17  | 18  | 19  | 20  | 21  | 22  | 23  | 24  | 25  | 26  | 27  | 28  | 29  | 30  | 31  | 32  |
| <b>Minimum reveal per door – allow for in distance calculation</b> |                   |     |     |     |     |     |     |     |     |     |     |     |     |     |     |     |     |
| Table entries apply to doors with 0 mm radius                      |                   |     |     |     |     |     |     |     |     |     |     |     |     |     |     |     |     |
| 3  | 0,4               | 0,6 | 0,8 | 1,0 | 1,2 | 1,5 | 1,8 | 2,1 | 2,5 | 2,9 | 3,4 | 4,0 | 4,9 | 5,7 | 6,6 | 7,5 | 8,4 |
| 4  | 0,4               | 0,6 | 0,8 | 1,0 | 1,2 | 1,5 | 1,8 | 2,1 | 2,5 | 2,8 | 3,3 | 3,8 | 4,5 | 5,3 | 6,1 | 7,0 | 7,9 |
| 4,5  | 0,4               | 0,6 | 0,8 | 1,0 | 1,2 | 1,5 | 1,8 | 2,1 | 2,5 | 2,8 | 3,3 | 3,7 | 4,3 | 5,1 | 5,9 | 6,8 | 7,7 |
| 5  | 0,4               | 0,6 | 0,8 | 1,0 | 1,2 | 1,4 | 1,7 | 2,0 | 2,4 | 2,7 | 3,2 | 3,6 | 4,2 | 4,9 | 5,7 | 6,5 | 7,4 |
| 6  | 0,4               | 0,6 | 0,8 | 1,0 | 1,2 | 1,4 | 1,7 | 2,0 | 2,3 | 2,6 | 3,1 | 3,5 | 4,0 | 4,6 | 5,3 | 6,1 | 6,9 |
| 7  | 0,4               | 0,5 | 0,7 | 0,9 | 1,1 | 1,3 | 1,6 | 1,9 | 2,2 | 2,6 | 3,0 | 3,4 | 3,9 | 4,4 | 5,0 | 5,7 | 6,5 |
| 8  | 0,4               | 0,5 | 0,7 | 0,9 | 1,1 | 1,3 | 1,6 | 1,8 | 2,1 | 2,5 | 2,9 | 3,3 | 3,7 | 4,2 | 4,8 | 5,4 | 6,1 |

### Note:

Drawings on this page are to full scale and show the hinges plus mounting plate distances. By drawing in the required cup distance C (3–8 mm), the door overlay can be measured directly from the applicable distance line.

The distance from the **cabinet front edge to X** on the selected distance line is also equal to the hole line distance from the cabinet front edge.

For **inset-mounted** doors, the cup distance and door thickness must be taken into account when determining the **minimum door reveal**.

The minimum reveal is reduced for doors with radii: 1 mm radius: table entry – 0,4 mm  
 3 mm radius: table entry – 1,2 mm

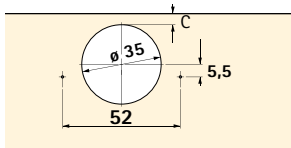

T42 hole dimensions

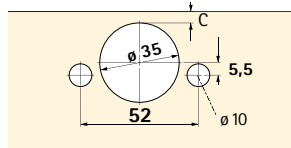

T43 / Flash hole dimensions

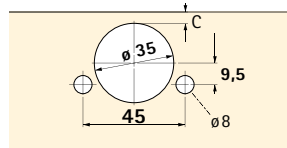

TB43 hole dimensions

### Full overlay

\* Overlay adjustment +2 mm / -4 mm

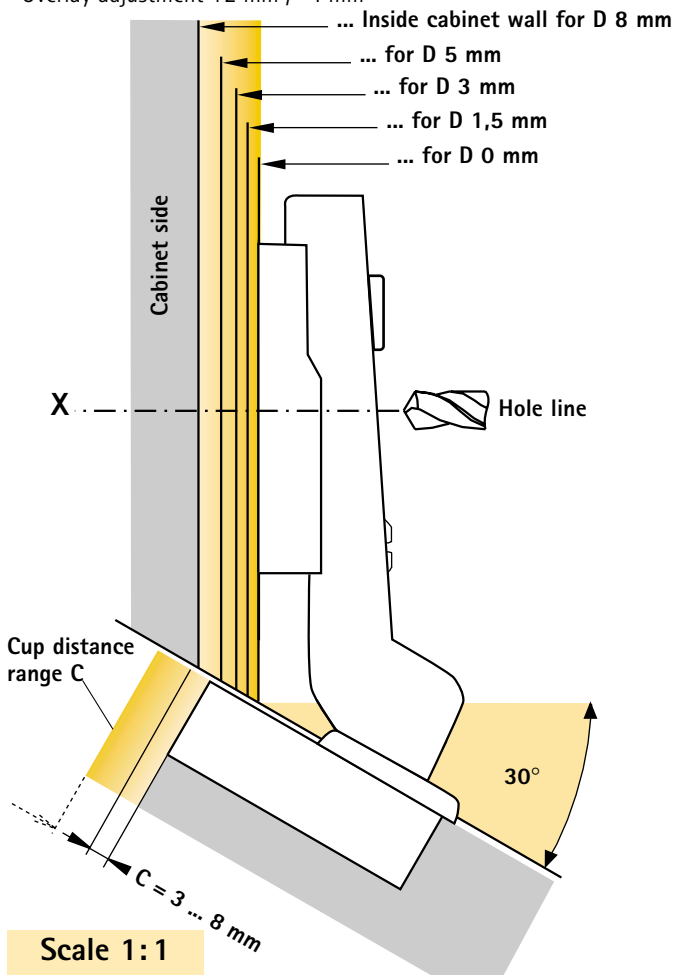

Scale 1:1

### Inset

\* Reveal adjustment -2 mm / +4 mm

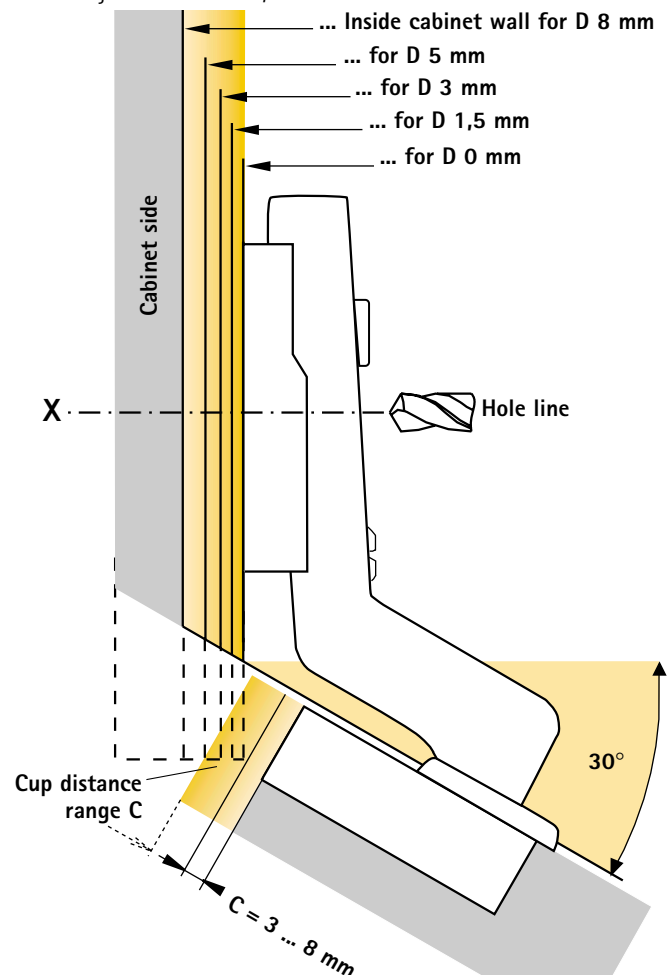

# Intermat 9936 W30 FIX

## Toolless fast-assembly for corner cabinets

### Opening angle 95°

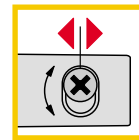
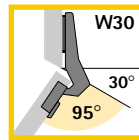

Concealed hinge, snap-on assembly and toolless cup assembly, free-swinging, integrated door overlay and eccentric depth adjustment.

Opening angle 95°, cup diameter 35 mm.

For corner cupboards and cabinets with 30° face angle.

Intermat 9936 W30 FIX hinges are snapped onto the mounting plate and also feature toolless cup assembly.

Depth adjustment via eccentric screw -0,5 mm/+3,5 mm.

Height adjustment via mounting plate +2 mm/-2 mm, see pages 3.110 - 3.112.

#### Cup version

**Cup T FIX**  
Toolless  
Nickel-plated steel



**Cup TH FIX**  
Toolless  
with pegs  
Nickel-plated steel

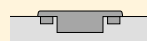

**Cup TB FIX**  
Toolless  
with pegs  
Nickel-plated steel



#### Hinge version

#### Mounting option

#### Article/order number



#### Full overlay

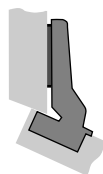

#### Intermat 9936 W30 FIX

- self-closing

Packaging unit 50 pcs

● 9936 W30-T FIX  
**077 693**

● 9936 W30-TH FIX  
**077 694**

● 9936 W30-TB FIX  
**077 695**

#### Door buffer Silent System



screw-on

**042 001**



drill-in

**048 047**



#### Inset

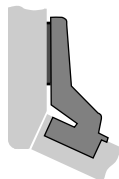

#### Intermat 9936 W30 FIX

- self-closing

Packaging unit 50 pcs

● 9936 W30-T FIX  
**077 696**

● 9936 W30-TH FIX  
**077 697**

● 9936 W30-TB FIX  
**077 698**

#### Door buffer Silent System



screw-on

**048 048**

#### Mounting example Intermat 9936 W30 FIX Full overlay

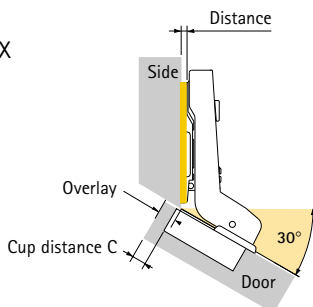

#### Mounting example Intermat 9936 W30 FIX Inset

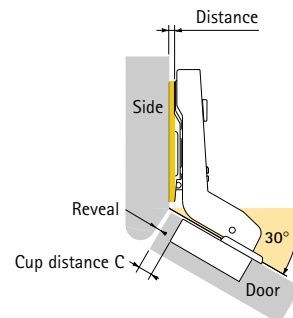

## Specification

Hettich Intermat 9936 W30 FIX  
 Snap-on assembly plus toolless cup assembly  
 Eccentric depth adjustment  
 for 30° face angle applications  
 Opening angle 95°

### Cover cap for Intermat hinges

Nickel-plated steel  
**Order no. 013 300**  
 Black plastic  
**Order no. 048 043**  
 PU = 50 pcs



| Cup distance<br>C mm   | Door thickness mm |     |     |     |     |     |     |     |     |     |     |     |     |     |     |     |     |
|--|-------------------|-----|-----|-----|-----|-----|-----|-----|-----|-----|-----|-----|-----|-----|-----|-----|-----|
|  | 16                | 17  | 18  | 19  | 20  | 21  | 22  | 23  | 24  | 25  | 26  | 27  | 28  | 29  | 30  | 31  | 32  |
| <b>Minimum reveal per door – allow for in distance calculation</b> |                   |     |     |     |     |     |     |     |     |     |     |     |     |     |     |     |     |
| Table entries apply to doors with 0 mm radius                      |                   |     |     |     |     |     |     |     |     |     |     |     |     |     |     |     |     |
| 3  | 0,4               | 0,6 | 0,8 | 1,0 | 1,2 | 1,5 | 1,8 | 2,1 | 2,5 | 2,9 | 3,4 | 4,0 | 4,9 | 5,7 | 6,6 | 7,5 | 8,4 |
| 4  | 0,4               | 0,6 | 0,8 | 1,0 | 1,2 | 1,5 | 1,8 | 2,1 | 2,5 | 2,8 | 3,3 | 3,8 | 4,5 | 5,3 | 6,1 | 7,0 | 7,9 |
| 4,5  | 0,4               | 0,6 | 0,8 | 1,0 | 1,2 | 1,5 | 1,8 | 2,1 | 2,5 | 2,8 | 3,3 | 3,7 | 4,3 | 5,1 | 5,9 | 6,8 | 7,7 |
| 5  | 0,4               | 0,6 | 0,8 | 1,0 | 1,2 | 1,4 | 1,7 | 2,0 | 2,4 | 2,7 | 3,2 | 3,6 | 4,2 | 4,9 | 5,7 | 6,5 | 7,4 |
| 6  | 0,4               | 0,6 | 0,8 | 1,0 | 1,2 | 1,4 | 1,7 | 2,0 | 2,3 | 2,6 | 3,1 | 3,5 | 4,0 | 4,6 | 5,3 | 6,1 | 6,9 |
| 7  | 0,4               | 0,5 | 0,7 | 0,9 | 1,1 | 1,3 | 1,6 | 1,9 | 2,2 | 2,6 | 3,0 | 3,4 | 3,9 | 4,4 | 5,0 | 5,7 | 6,5 |
| 8  | 0,4               | 0,5 | 0,7 | 0,9 | 1,1 | 1,3 | 1,6 | 1,8 | 2,1 | 2,5 | 2,9 | 3,3 | 3,7 | 4,2 | 4,8 | 5,4 | 6,1 |

### Note:

Drawings on this page are to full scale and show the hinges plus mounting plate distances. By drawing in the required cup distance C (3–8 mm), the door overlay can be measured directly from the applicable distance line.

The distance from the **cabinet front edge to X** on the selected distance line is also equal to the hole line distance from the cabinet front edge.

For **inset-mounted** doors, the cup distance and door thickness must be taken into account when determining the **minimum door reveal**.

The minimum reveal is reduced for doors with radii: 1 mm radius: table entry – 0,4 mm  
 3 mm radius: table entry – 1,2 mm

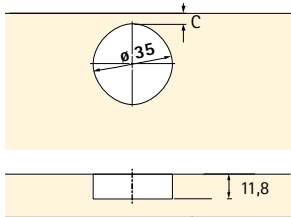

T FIX hole dimensions

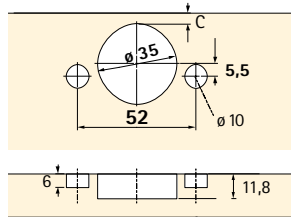

TH FIX hole dimensions

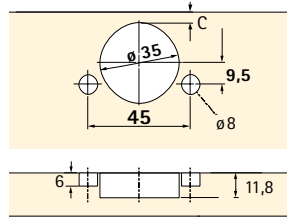

TB FIX hole dimensions

### Full overlay

\* Overlay adjustment +2 mm / -4 mm

### Inset

\* Reveal adjustment -2 mm / +4 mm

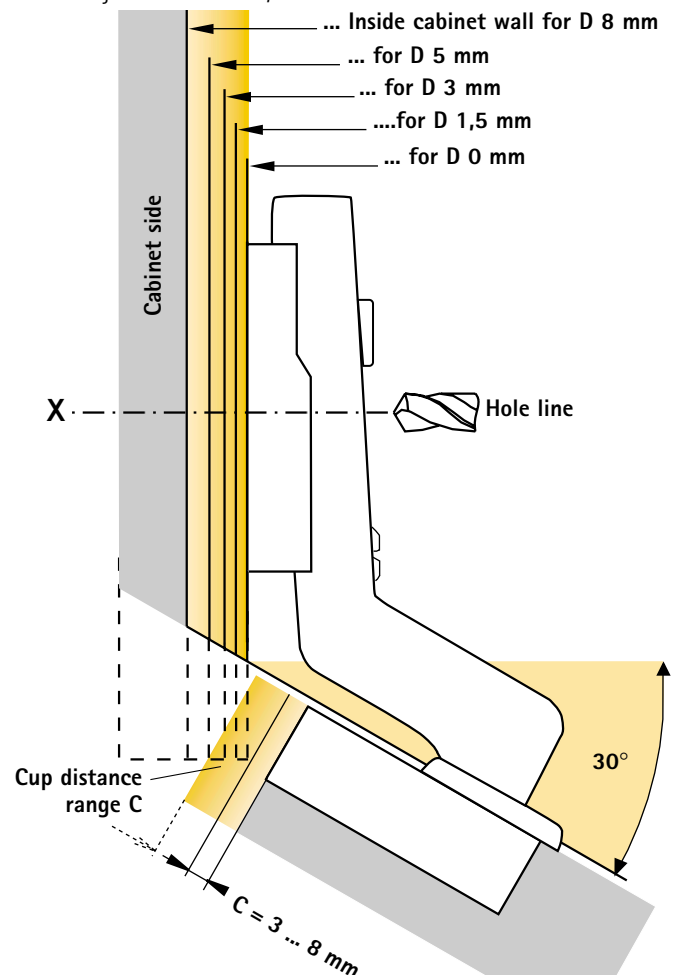
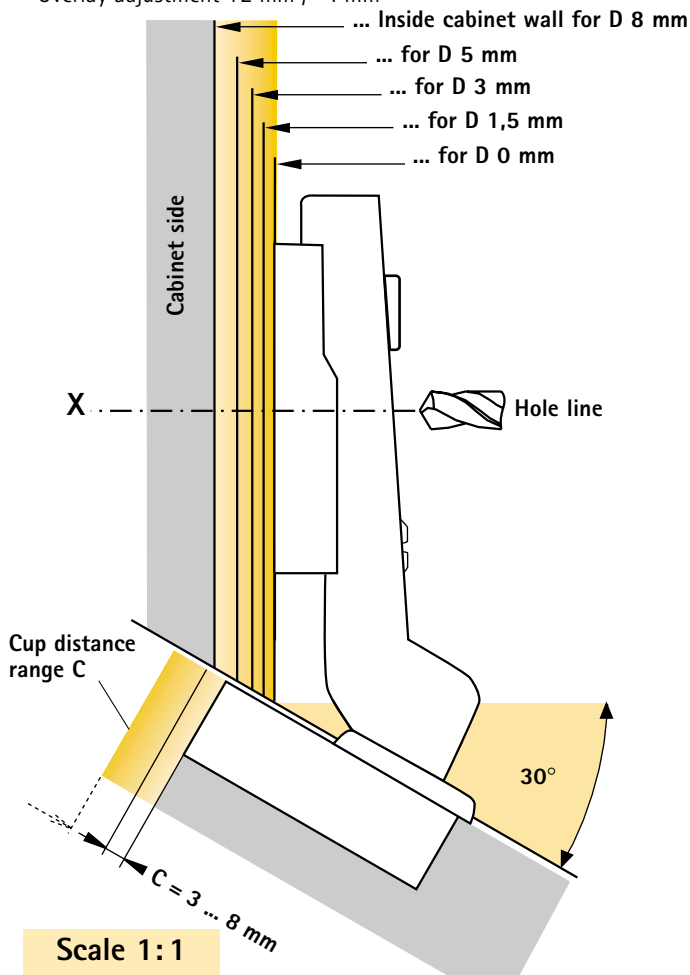

# Intermat 9936 W45

## Fast-assembly hinge for corner cabinets

### Opening angle 95°

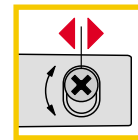
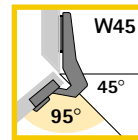

**Concealed hinge, snap-on assembly, integrated door overlay and eccentric depth adjustment.**

Opening angle 95°, cup diameter 35 mm.

For corner cupboards and cabinets with 45° face angle.

Intermat 9936 W45 hinges are snapped onto the mounting plate.

Depth adjustment via eccentric screw -0,5 mm/+3,5 mm.

Height adjustment via mounting plate +2 mm/-2 mm, see pages 3.110 - 3.112.

Cup fixing screw  $\varnothing$  3,5 x 13 mm nickel-plated, for cup T 42

Order no. 048 296, PU 200

#### Cup version

##### Cup T 42

Screw-on  
Nickel-plated  
steel

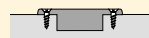

##### Cup T 43

Press-in  
Nickel-plated  
steel



##### Cup TB 43

Press-in  
Nickel-plated  
steel

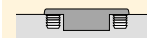

##### Cup Flash

Fast-assembly  
Nickel-plated  
steel



#### Hinge version

#### Mounting option

#### Article/order number

Cranking 0 mm

Full overlay

#### Intermat 9936 W45

● self-closing

Packaging unit 50 pcs

● 9936 W45-T42  
048 096

● 9936 W45-T43  
048 097

● 9936 W45-TB 43  
048 098

● 9936 W45-Flash  
048 099

#### Door buffer Silent System



screw-on

042 001



drill-in

048 047

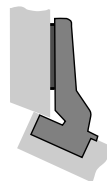

Cranking 6 mm

Half overlay

#### Intermat 9936 W45

● self-closing

Packaging unit 50 pcs

● 9936 W45-T42  
077 699

● 9936 W45-T43  
077 700

● 9936 W45-TB 43  
077 701

● 9936 W45-Flash  
079 303

#### Door buffer Silent System



screw-on

042 001



drill-in

048 047

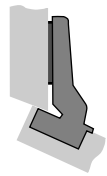

Cranking - 17 mm

Inset

#### Intermat 9936 W45

● self-closing

Packaging unit 50 pcs

● 9936 W45-T42  
073 932

● 9936 W45-T43  
073 933

● 9936 W45-TB 43  
073 934

● 9936 W45-Flash  
073 935

#### Door buffer Silent System



screw-on

048 048

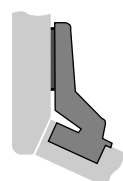

## Specification

Hettich Intermat 9936 W45  
 Snap-on assembly  
 Eccentric depth adjustment  
 for 45° face angles  
 Opening angle 95°

### Cover cap for Intermat hinges

Nickel-plated steel  
**Order no. 013 300**  
 Black plastic  
**Order no. 048 043**  
 PU = 50 pcs

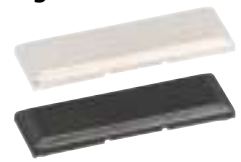

| Cup distance<br>C mm   | Door thickness mm |     |     |     |     |     |     |     |     |     |     |     |     |     |     |     |     |
|--|-------------------|-----|-----|-----|-----|-----|-----|-----|-----|-----|-----|-----|-----|-----|-----|-----|-----|
|  | 16                | 17  | 18  | 19  | 20  | 21  | 22  | 23  | 24  | 25  | 26  | 27  | 28  | 29  | 30  | 31  | 32  |
| <b>Minimum reveal per door – allow for in distance calculation</b> |                   |     |     |     |     |     |     |     |     |     |     |     |     |     |     |     |     |
| Table entries apply to doors with 0 mm radius                      |                   |     |     |     |     |     |     |     |     |     |     |     |     |     |     |     |     |
| 3  | 0,4               | 0,6 | 0,8 | 1,0 | 1,2 | 1,5 | 1,8 | 2,1 | 2,5 | 2,9 | 3,4 | 4,0 | 4,9 | 5,7 | 6,6 | 7,5 | 8,4 |
| 4  | 0,4               | 0,6 | 0,8 | 1,0 | 1,2 | 1,5 | 1,8 | 2,1 | 2,5 | 2,8 | 3,3 | 3,8 | 4,5 | 5,3 | 6,1 | 7,0 | 7,9 |
| 4,5  | 0,4               | 0,6 | 0,8 | 1,0 | 1,2 | 1,5 | 1,8 | 2,1 | 2,5 | 2,8 | 3,3 | 3,7 | 4,3 | 5,1 | 5,9 | 6,8 | 7,7 |
| 5  | 0,4               | 0,6 | 0,8 | 1,0 | 1,2 | 1,4 | 1,7 | 2,0 | 2,4 | 2,7 | 3,2 | 3,6 | 4,2 | 4,9 | 5,7 | 6,5 | 7,4 |
| 6  | 0,4               | 0,6 | 0,8 | 1,0 | 1,2 | 1,4 | 1,7 | 2,0 | 2,3 | 2,6 | 3,1 | 3,5 | 4,0 | 4,6 | 5,3 | 6,1 | 6,9 |
| 7  | 0,4               | 0,5 | 0,7 | 0,9 | 1,1 | 1,3 | 1,6 | 1,9 | 2,2 | 2,6 | 3,0 | 3,4 | 3,9 | 4,4 | 5,0 | 5,7 | 6,5 |
| 8  | 0,4               | 0,5 | 0,7 | 0,9 | 1,1 | 1,3 | 1,6 | 1,8 | 2,1 | 2,5 | 2,9 | 3,3 | 3,7 | 4,2 | 4,8 | 5,4 | 6,1 |

### Note:

Drawings on this page are to full scale and show the hinges plus mounting plate distances. By drawing in the required cup distance C (3–8 mm), the door overlay can be measured directly from the applicable distance line.

The distance from the **cabinet front edge to X** on the selected distance line is also equal to the hole line distance from the cabinet front edge.

For **inset-mounted** doors, the cup distance and door thickness must be taken into account when determining the **minimum door reveal**.

The minimum reveal is reduced for doors with radii: 1 mm radius: table entry – 0,4 mm  
 3 mm radius: table entry – 1,2 mm

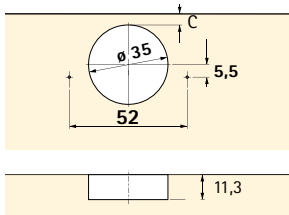

T42 hole dimensions

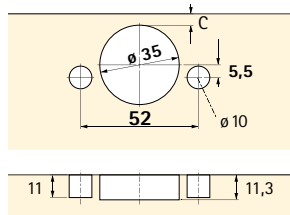

T43 / Flash hole dimensions

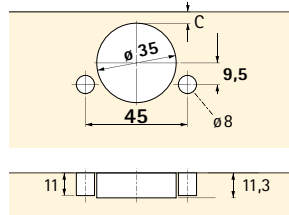

TB43 hole dimensions

### Mounting example

Intermat 9936 W45

Full overlay

Cranking 0 mm

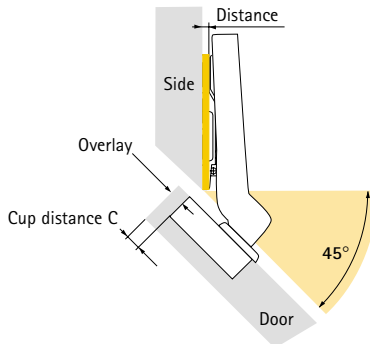

### Full overlay, cranking 0 mm

\* Overlay adjustment +2 mm / -4 mm

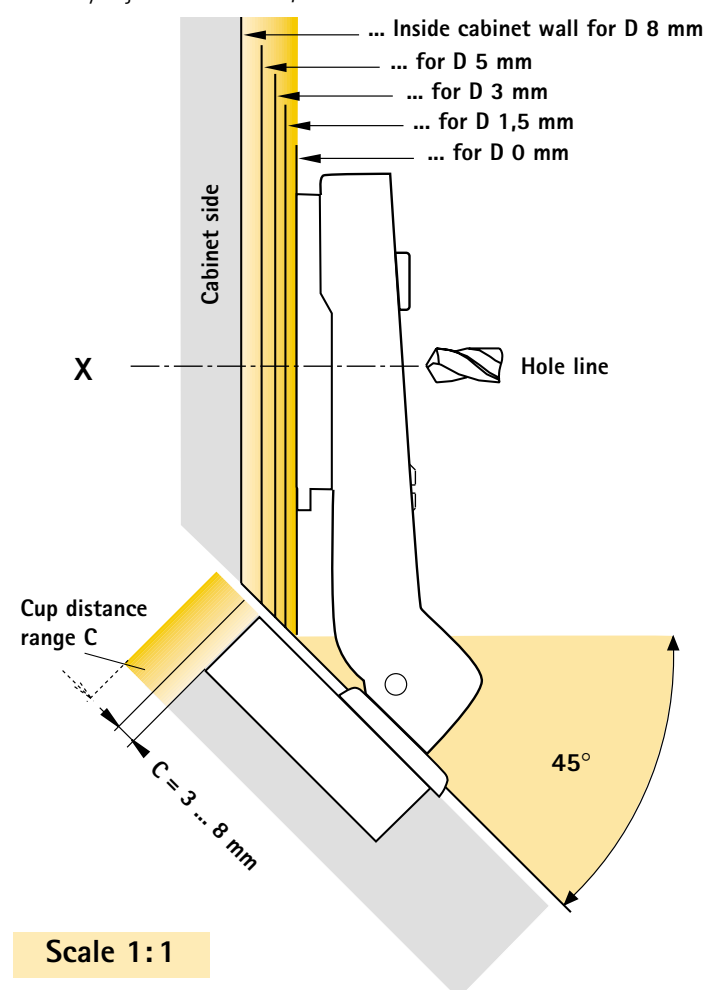

Scale 1:1

# Intermat 9936 W45

## Fast-assembly hinge for corner cabinets

### Opening angle 95°

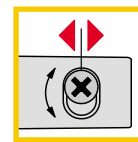
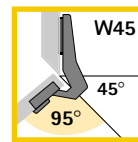

Full overlay, cranking 6 mm

\* Overlay adjustment +2 mm / -4 mm

Inset, cranking -17 mm

\* Reveal adjustment -2 mm / +4 mm

3

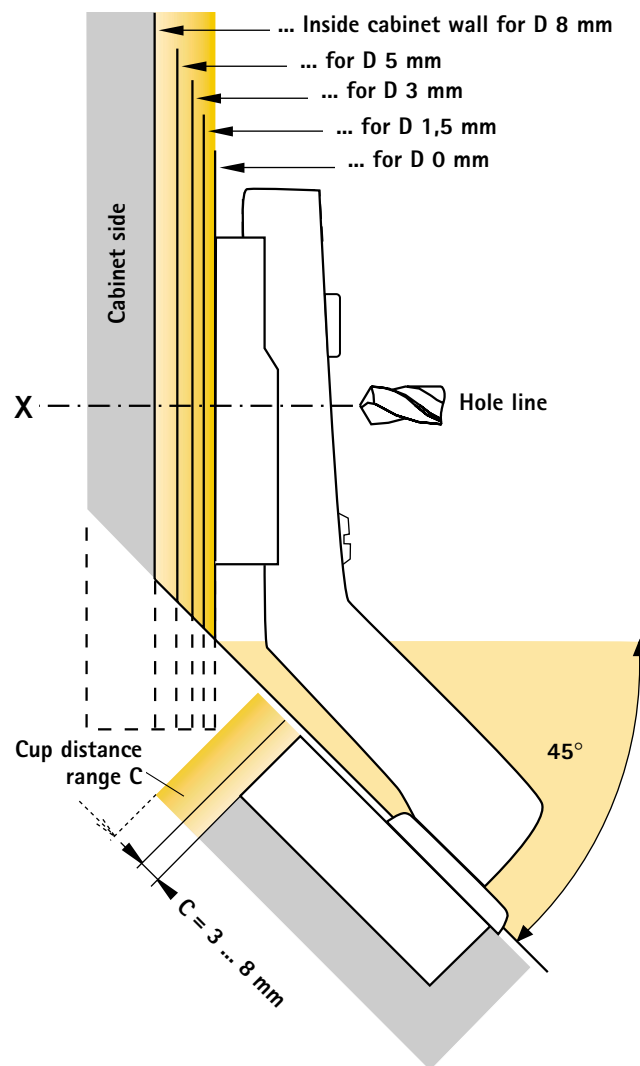
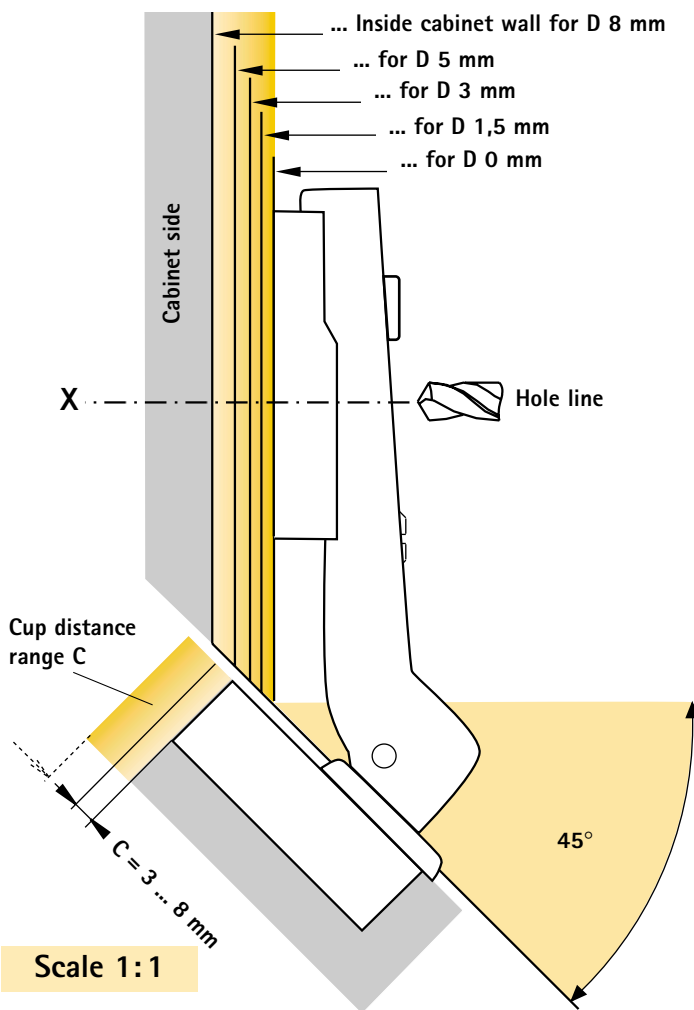

#### Mounting example

Intermat 9936 W45

Full overlay

Cranking 6 mm

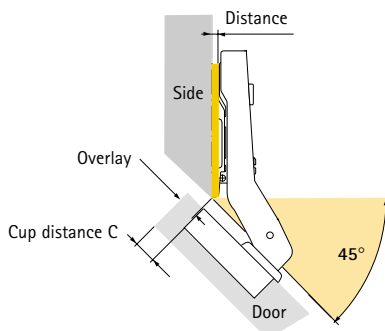

#### Mounting example

Intermat 9936 W45

Inset

Cranking -17 mm

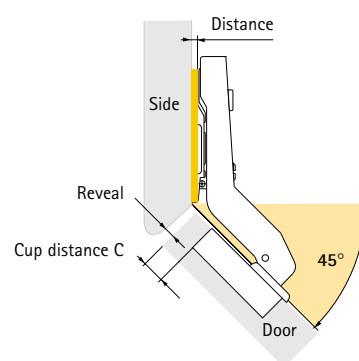

# Intermat 9936 W45 FIX

## Toolless fast-assembly for corner cabinets

### Opening angle 95°

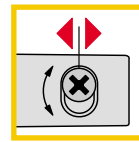
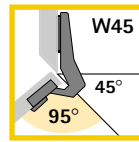
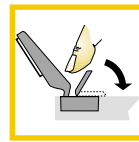

Concealed hinge, snap-on assembly and toolless cup assembly, integrated door overlay and eccentric depth adjustment.

Opening angle 95°, cup diameter 35 mm.

For corner cupboards and cabinets with 45° face angle.

Intermat 9936 W45 FIX hinges are snapped onto the mounting plate and also feature toolless cup assembly.

Depth adjustment via eccentric screw -0,5 mm/+3,5 mm.

Height adjustment via mounting plate +2 mm/-2 mm, see pages 3.110 - 3.112.

Cover caps, see page 3.67

#### Cup version

**Cup T FIX**  
Toolless  
Nickel-plated steel

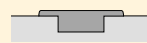

**Cup TH FIX**  
Toolless  
with pegs  
Nickel-plated steel

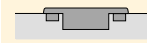

**Cup TB FIX**  
Toolless  
with pegs  
Nickel-plated steel

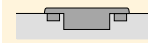

#### Hinge version

#### Mounting option

#### Article/order number



#### Full overlay

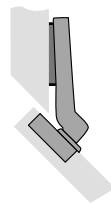

#### Intermat 9936 W45 FIX

- self-closing

Packaging unit 50 pcs

● 9936 W45-T FIX  
**048 101**

● 9936 W45-TH FIX  
**048 103**

● 9936 W45-TB FIX  
**048 104**

#### Door buffer Silent System



screw-on

**042 001**



drill-in

**048 047**



#### Half overlay

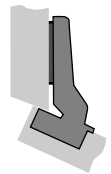

#### Intermat 9936 W45 FIX

- self-closing

Packaging unit 50 pcs

● 9936 W45-T FIX  
**077 702**

● 9936 W45-TH FIX  
**077 703**

● 9936 W45-TB FIX  
**077 704**

#### Door buffer Silent System



screw-on

**042 001**



drill-in

**048 047**



#### Inset

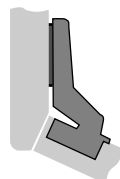

#### Intermat 9936 W45 FIX

- self-closing

Packaging unit 50 pcs

● 9936 W45-T FIX  
**077 705**

● 9936 W45-TH FIX  
**077 706**

● 9936 W45-TB FIX  
**077 707**

#### Door buffer Silent System



screw-on

**048 048**

For mounting examples for different cabinet face angles, see pages 3.115 - 3.133.

# Intermat 9936 W45 FIX

## Toolless fast-assembly for corner cabinets

### Opening angle 95°

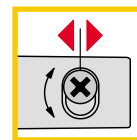
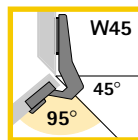
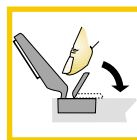

| Cup distance<br>C mm   | Door thickness mm |     |     |     |     |     |     |     |     |     |     |     |     |     |     |     |     |
|--|-------------------|-----|-----|-----|-----|-----|-----|-----|-----|-----|-----|-----|-----|-----|-----|-----|-----|
|  | 16                | 17  | 18  | 19  | 20  | 21  | 22  | 23  | 24  | 25  | 26  | 27  | 28  | 29  | 30  | 31  | 32  |
| <b>Minimum reveal per door – allow for in distance calculation</b> |                   |     |     |     |     |     |     |     |     |     |     |     |     |     |     |     |     |
| Table entries apply to doors with 0 mm radius                      |                   |     |     |     |     |     |     |     |     |     |     |     |     |     |     |     |     |
| 3  | 0,4               | 0,6 | 0,8 | 1,0 | 1,2 | 1,5 | 1,8 | 2,1 | 2,5 | 2,9 | 3,4 | 4,0 | 4,9 | 5,7 | 6,6 | 7,5 | 8,4 |
| 4  | 0,4               | 0,6 | 0,8 | 1,0 | 1,2 | 1,5 | 1,8 | 2,1 | 2,5 | 2,8 | 3,3 | 3,8 | 4,5 | 5,3 | 6,1 | 7,0 | 7,9 |
| 4,5  | 0,4               | 0,6 | 0,8 | 1,0 | 1,2 | 1,5 | 1,8 | 2,1 | 2,5 | 2,8 | 3,3 | 3,7 | 4,3 | 5,1 | 5,9 | 6,8 | 7,7 |
| 5  | 0,4               | 0,6 | 0,8 | 1,0 | 1,2 | 1,4 | 1,7 | 2,0 | 2,4 | 2,7 | 3,2 | 3,6 | 4,2 | 4,9 | 5,7 | 6,5 | 7,4 |
| 6  | 0,4               | 0,6 | 0,8 | 1,0 | 1,2 | 1,4 | 1,7 | 2,0 | 2,3 | 2,6 | 3,1 | 3,5 | 4,0 | 4,6 | 5,3 | 6,1 | 6,9 |
| 7  | 0,4               | 0,5 | 0,7 | 0,9 | 1,1 | 1,3 | 1,6 | 1,9 | 2,2 | 2,6 | 3,0 | 3,4 | 3,9 | 4,4 | 5,0 | 5,7 | 6,5 |
| 8  | 0,4               | 0,5 | 0,7 | 0,9 | 1,1 | 1,3 | 1,6 | 1,8 | 2,1 | 2,5 | 2,9 | 3,3 | 3,7 | 4,2 | 4,8 | 5,4 | 6,1 |

#### Note:

Drawings on this page are to full scale and show the hinges plus mounting plate distances. By drawing in the required cup distance C (3–8 mm), the door overlay can be measured directly from the applicable distance line.

The distance from the **cabinet front edge to X** on the selected distance line is also equal to the hole line distance from the cabinet front edge.

For **inset-mounted** doors, the cup distance and door thickness must be taken into account when determining the **minimum door reveal**.

The minimum reveal is reduced for doors with radii: 1 mm radius: table entry – 0,4 mm  
3 mm radius: table entry – 1,2 mm

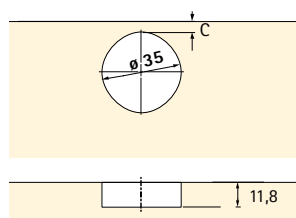

T FIX hole dimensions

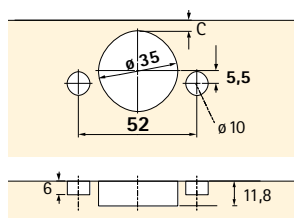

TH FIX hole dimensions

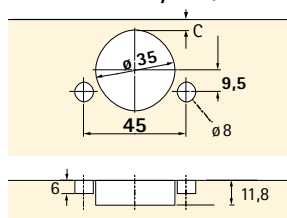

TB FIX hole dimensions

#### Mounting example

Intermat 9936 W45 Fix

Full overlay

Cranking 0 mm

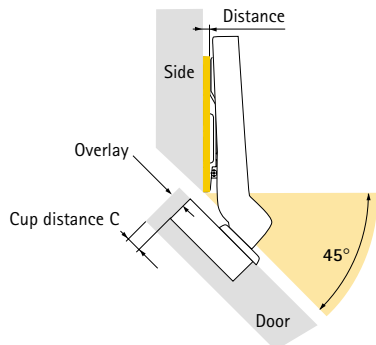

#### Full overlay, cranking 0 mm

\* Overlay adjustment +2 mm / -4 mm

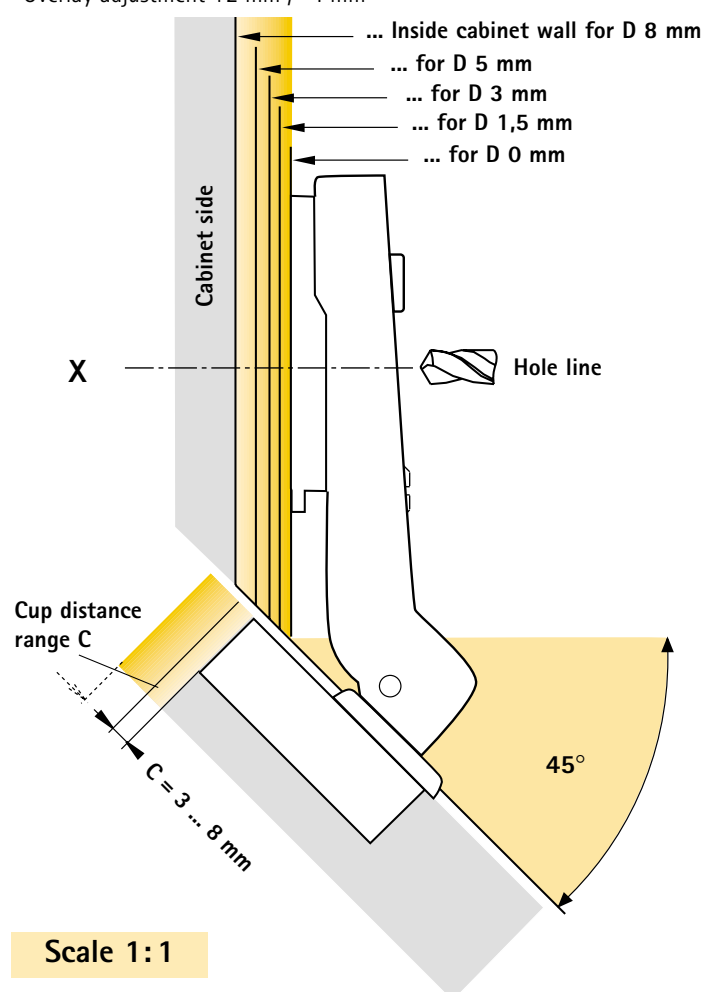

Scale 1:1

**Specification**

Hettich Intermat 9936 W45 FIX  
 Snap-on assembly plus toolless cup assembly  
 Eccentric depth adjustment  
 for 45° face angle applications  
 Opening angle 95°

**Cover cap for Intermat hinges**

Nickel-plated steel  
**Order no. 013 300**  
 Black plastic  
**Order no. 048 043**  
 PU = 50 pcs



**Full overlay, cranking 6 mm**

\* Overlay adjustment +2 mm / -4 mm

**Inset, cranking - 17 mm**

\* Reveal adjustment -2 mm / +4 mm

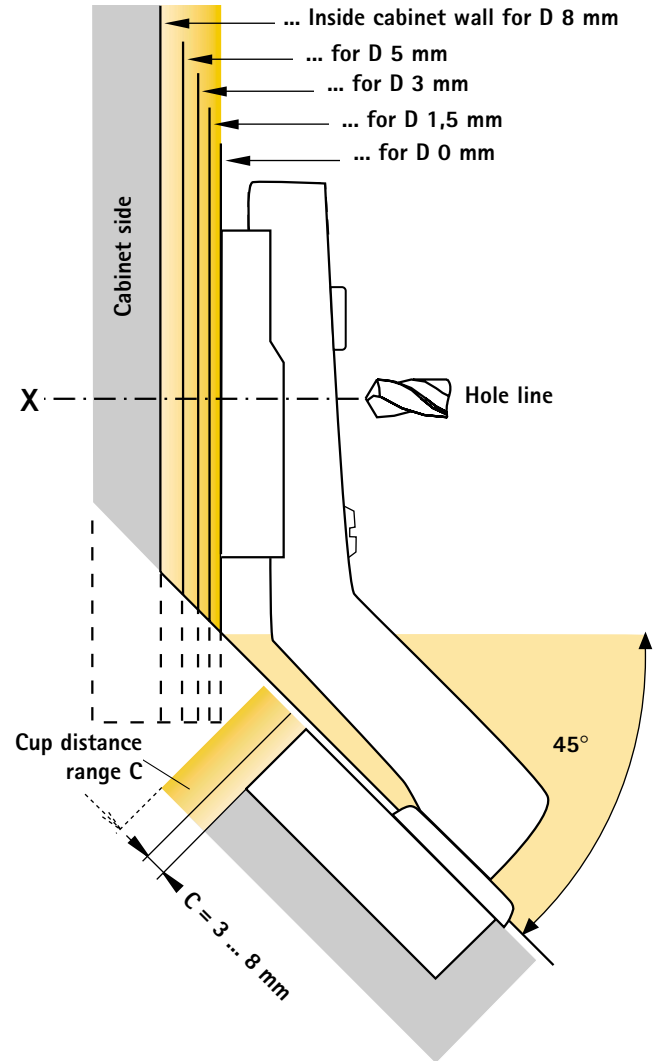
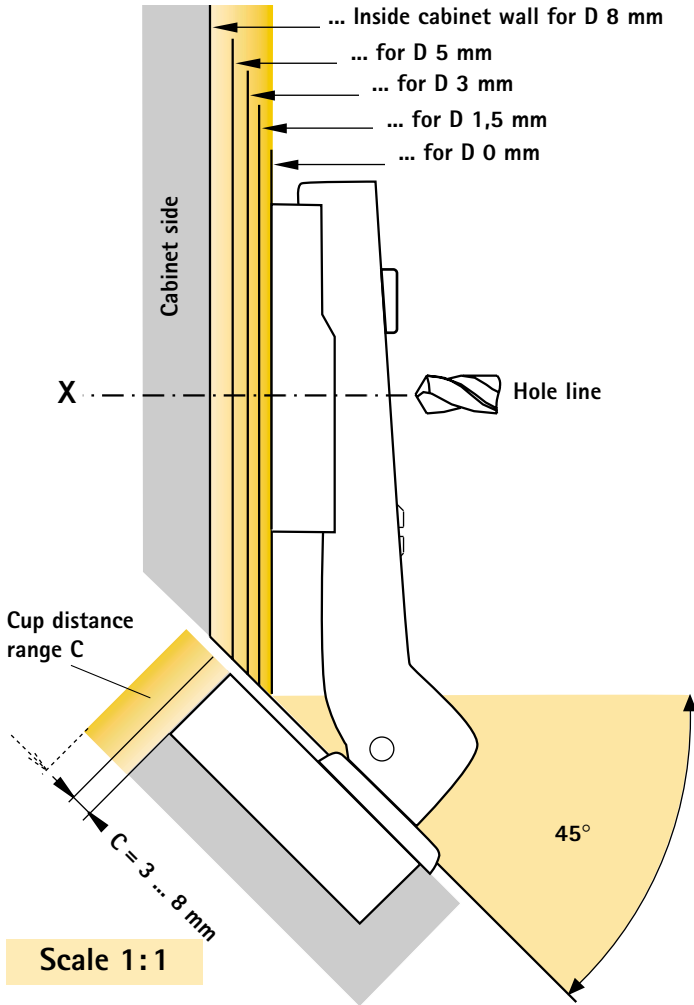

**Mounting example**

Intermat 9936 W45  
**Full overlay**  
 Cranking 6 mm

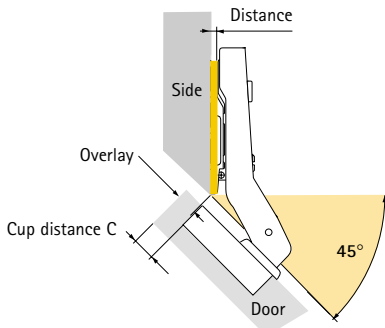

**Mounting example**

Intermat 9936 W45  
**Inset**  
 Cranking - 17 mm

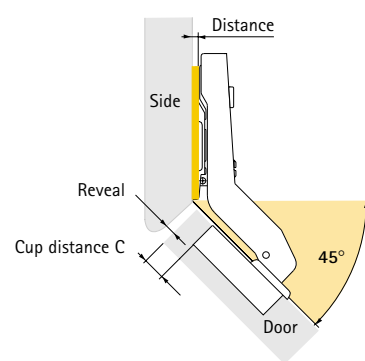

# Intermat 9936 W90

## Fast-assembly hinge for face frame cabinets

### Opening angle 95°

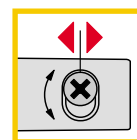
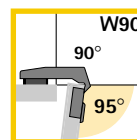

**Concealed hinge, snap-on assembly, integrated door overlay and eccentric reveal adjustment.**

Opening angle 95°, cup diameter 35 mm.

For corner cabinets with blind panels.

Intermat 9936 W90 hinges are snapped onto the mounting plate.

Reveal adjustment via eccentric screw -0,5 mm/+3,5 mm.

Height adjustment via mounting plate +2 mm/-2 mm, see pages 3.110 - 3.111.

Cup fixing screw  $\varnothing$  3,5 x 13 mm nickel-plated, for cup T 42

Order no. 048 296, PU 200

#### Cup version

##### Cup T 42

Screw-on  
Nickel-plated  
steel

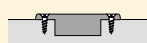

##### Cup T 43

Press-in  
Nickel-plated  
steel

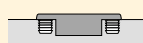

##### Cup TB 43

Press-in  
Nickel-plated  
steel

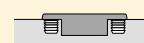

##### Cup Flash

Fast-assembly  
Nickel-plated  
steel

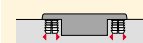

#### Hinge version



#### Mounting option

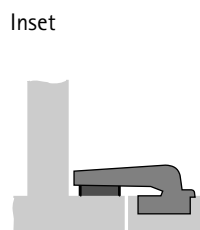

#### Article/order number

##### Intermat 9936 W90

- self-closing

Packaging unit 50 pcs

● 9936 W90-T42  
**077 708**

● 9936 W90-T43  
**077 709**

● 9936 W90-TB 43  
**077 710**

● 9936 W90-Flash  
**079 304**

##### Door buffer Silent System

 screw-on

**042 001**

 drill-in

**048 047**

## Specification

Hettich Intermat 9936 W90

Snap-on assembly

Eccentric reveal adjustment

for 90° face frame applications

Opening angle 95°

### Cover cap for Intermat hinges

Nickel-plated steel

Order no. **013 300**

Black plastic

Order no. **048 043**

PU = 50 pcs



| Cup distance<br>C mm   | Door thickness mm |     |     |     |     |     |     |     |     |     |     |     |     |     |     |     |     |
|--|-------------------|-----|-----|-----|-----|-----|-----|-----|-----|-----|-----|-----|-----|-----|-----|-----|-----|
|  | 16                | 17  | 18  | 19  | 20  | 21  | 22  | 23  | 24  | 25  | 26  | 27  | 28  | 29  | 30  | 31  | 32  |
| <b>Minimum reveal per door – allow for in distance calculation</b> |                   |     |     |     |     |     |     |     |     |     |     |     |     |     |     |     |     |
| Table entries apply to doors with 0 mm radius                      |                   |     |     |     |     |     |     |     |     |     |     |     |     |     |     |     |     |
| 3  | 0,4               | 0,6 | 0,8 | 1,0 | 1,2 | 1,5 | 1,8 | 2,1 | 2,5 | 2,9 | 3,4 | 4,0 | 4,9 | 5,7 | 6,6 | 7,5 | 8,4 |
| 4  | 0,4               | 0,6 | 0,8 | 1,0 | 1,2 | 1,5 | 1,8 | 2,1 | 2,5 | 2,8 | 3,3 | 3,8 | 4,5 | 5,3 | 6,1 | 7,0 | 7,9 |
| 4,5  | 0,4               | 0,6 | 0,8 | 1,0 | 1,2 | 1,5 | 1,8 | 2,1 | 2,5 | 2,8 | 3,3 | 3,7 | 4,3 | 5,1 | 5,9 | 6,8 | 7,7 |
| 5  | 0,4               | 0,6 | 0,8 | 1,0 | 1,2 | 1,4 | 1,7 | 2,0 | 2,4 | 2,7 | 3,2 | 3,6 | 4,2 | 4,9 | 5,7 | 6,5 | 7,4 |
| 6  | 0,4               | 0,6 | 0,8 | 1,0 | 1,2 | 1,4 | 1,7 | 2,0 | 2,3 | 2,6 | 3,1 | 3,5 | 4,0 | 4,6 | 5,3 | 6,1 | 6,9 |
| 7  | 0,4               | 0,5 | 0,7 | 0,9 | 1,1 | 1,3 | 1,6 | 1,9 | 2,2 | 2,6 | 3,0 | 3,4 | 3,9 | 4,4 | 5,0 | 5,7 | 6,5 |
| 8  | 0,4               | 0,5 | 0,7 | 0,9 | 1,1 | 1,3 | 1,6 | 1,8 | 2,1 | 2,5 | 2,9 | 3,3 | 3,7 | 4,2 | 4,8 | 5,4 | 6,1 |

The minimum reveal is reduced for doors with radii: 1 mm radius: table entry – 0,4 mm  
3 mm radius: table entry – 1,2 mm

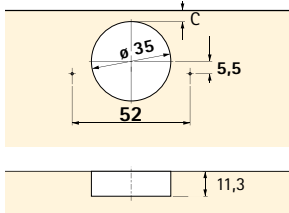

T42 hole dimensions

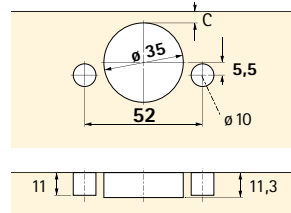

T43 / Flash hole dimensions

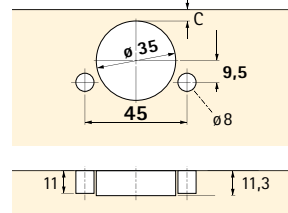

TB43 hole dimensions

## Mounting example

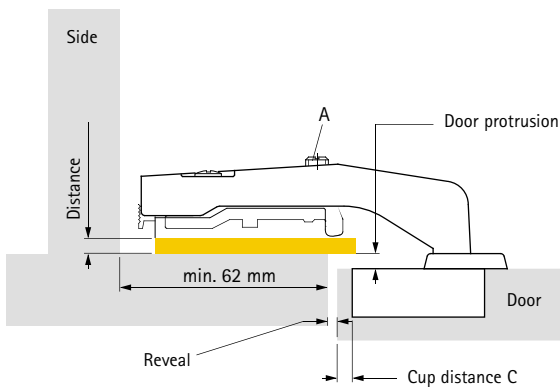

## Calculating distance

$$\text{Distance} = 5 \text{ mm} - \text{door protrusion}$$

The hinges are adjusted correctly ex factory.  
The door protrusion can be adjusted if necessary.  
Turn screw (A) clockwise:  
The door protrusion can be adjusted by up to 6 mm (+2 mm/-4 mm).

The back of the door and front panel will be flush if a mounting plate with distance 5mm is used.

\* The hole distance X, cup distance C and the reveal must always add up to 28!

$$X + \text{cup distance C} + \text{reveal} = 28$$

## Calculating hole distance "X"

| Cup distance<br>C mm | Reveal mm |      |      |      |      |      |      |
|----------------------|-----------|------|------|------|------|------|------|
|                      | 0         | 0,5  | 1,0  | 1,5  | 2,0  | 2,5  | 3,0  |
| 3                    | 25,0      | 24,5 | 24,0 | 23,5 | 23,0 | 22,5 | 22,0 |
| 3,5                  | 24,5      | 24,0 | 23,5 | 23,0 | 22,5 | 22,0 | 21,5 |
| 4                    | 24,0      | 23,5 | 23,0 | 22,5 | 22,0 | 21,5 | 21,0 |
| 4,5                  | 23,5      | 23,0 | 22,5 | 22,0 | 21,5 | 21,0 | 20,5 |
| 5                    | 23,0      | 22,5 | 22,0 | 21,5 | 21,0 | 20,5 | 20,0 |
| 5,5                  | 22,5      | 22,0 | 21,5 | 21,0 | 20,5 | 20,0 | 19,5 |
| 6                    | 22,0      | 21,5 | 21,0 | 20,5 | 20,0 | 19,5 | 19,0 |
| 7                    | 21,0      | 20,5 | 20,0 | 19,5 | 19,0 | 18,5 | 18,0 |
| 8                    | 20,0      | 19,5 | 19,0 | 18,5 | 18,0 | 17,5 | 17,0 |

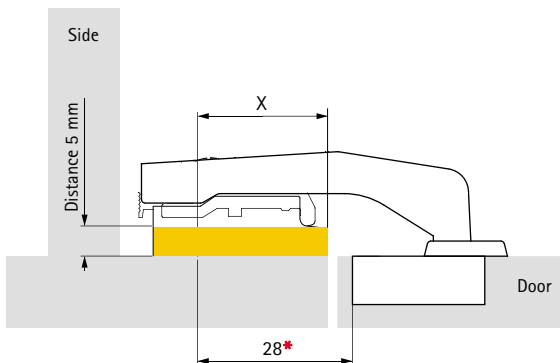

# Intermat 9936 W90 FIX

## Toolless fast-assembly for face frame cabinets

### Opening angle 95°

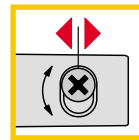
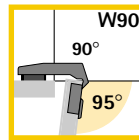
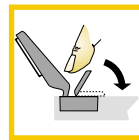

**Concealed hinge, snap-on assembly and toolless cup assembly, integrated door overlay and eccentric depth adjustment.**

Opening angle 95°, cup diameter 35 mm.

For corner cabinets with blind panels.

Intermat 9936 W45 FIX hinges are snapped onto the mounting plate and also feature toolless cup assembly.

Reveal adjustment via eccentric screw -0,5 mm/+3,5 mm.

Height adjustment via mounting plate +2 mm/-2 mm, see pages 3.110 - 3.111.

#### Cup version

**Cup T FIX**  
Toolless  
Nickel-plated steel

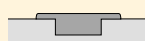

**Cup TH FIX**  
Toolless  
with pegs  
Nickel-plated steel



**Cup TB FIX**  
Toolless  
with pegs  
Nickel-plated steel

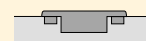

#### Hinge version



#### Mounting option

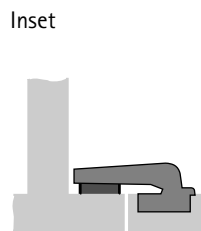

#### Article/order number

##### Intermat 9936 W90 FIX

- self-closing

Packaging unit 50 pcs

● 9936 W90-T FIX  
077 711

● 9936 W90-TH FIX  
077 712

● 9936 W90-TB FIX  
077 713

##### Door buffer Silent System

- screw-on
- drill-in

042 001

048 047

## Specification

Hettich Intermat 9936 W90 FIX  
 Snap-on assembly plus toolless cup assembly  
 Eccentric reveal adjustment  
 for 90° face frame applications  
 Opening angle 95°

### Cover cap for Intermat hinges

Nickel-plated steel  
**Order no. 013 300**  
 Black plastic  
**Order no. 048 043**  
 PU = 50 pcs



| Cup distance<br>C mm   | Door thickness mm |     |     |     |     |     |     |     |     |     |     |     |     |     |     |     |     |
|--|-------------------|-----|-----|-----|-----|-----|-----|-----|-----|-----|-----|-----|-----|-----|-----|-----|-----|
|  | 16                | 17  | 18  | 19  | 20  | 21  | 22  | 23  | 24  | 25  | 26  | 27  | 28  | 29  | 30  | 31  | 32  |
| <b>Minimum reveal per door – allow for in distance calculation</b> |                   |     |     |     |     |     |     |     |     |     |     |     |     |     |     |     |     |
| Table entries apply to doors with 0 mm radius                      |                   |     |     |     |     |     |     |     |     |     |     |     |     |     |     |     |     |
| 3  | 0,4               | 0,6 | 0,8 | 1,0 | 1,2 | 1,5 | 1,8 | 2,1 | 2,5 | 2,9 | 3,4 | 4,0 | 4,9 | 5,7 | 6,6 | 7,5 | 8,4 |
| 4  | 0,4               | 0,6 | 0,8 | 1,0 | 1,2 | 1,5 | 1,8 | 2,1 | 2,5 | 2,8 | 3,3 | 3,8 | 4,5 | 5,3 | 6,1 | 7,0 | 7,9 |
| 4,5  | 0,4               | 0,6 | 0,8 | 1,0 | 1,2 | 1,5 | 1,8 | 2,1 | 2,5 | 2,8 | 3,3 | 3,7 | 4,3 | 5,1 | 5,9 | 6,8 | 7,7 |
| 5  | 0,4               | 0,6 | 0,8 | 1,0 | 1,2 | 1,4 | 1,7 | 2,0 | 2,4 | 2,7 | 3,2 | 3,6 | 4,2 | 4,9 | 5,7 | 6,5 | 7,4 |
| 6  | 0,4               | 0,6 | 0,8 | 1,0 | 1,2 | 1,4 | 1,7 | 2,0 | 2,3 | 2,6 | 3,1 | 3,5 | 4,0 | 4,6 | 5,3 | 6,1 | 6,9 |
| 7  | 0,4               | 0,5 | 0,7 | 0,9 | 1,1 | 1,3 | 1,6 | 1,9 | 2,2 | 2,6 | 3,0 | 3,4 | 3,9 | 4,4 | 5,0 | 5,7 | 6,5 |
| 8  | 0,4               | 0,5 | 0,7 | 0,9 | 1,1 | 1,3 | 1,6 | 1,8 | 2,1 | 2,5 | 2,9 | 3,3 | 3,7 | 4,2 | 4,8 | 5,4 | 6,1 |

The minimum reveal is reduced for doors with radii: 1 mm radius: table entry – 0,4 mm  
 3 mm radius: table entry – 1,2 mm

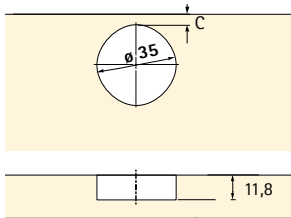

T FIX hole dimensions

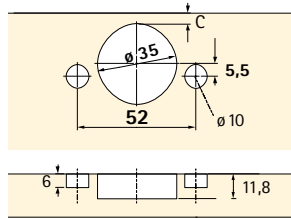

TH FIX hole dimensions

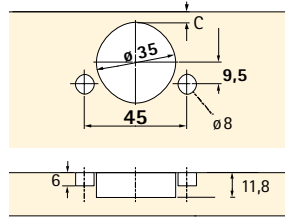

TB FIX hole dimensions

## Mounting example

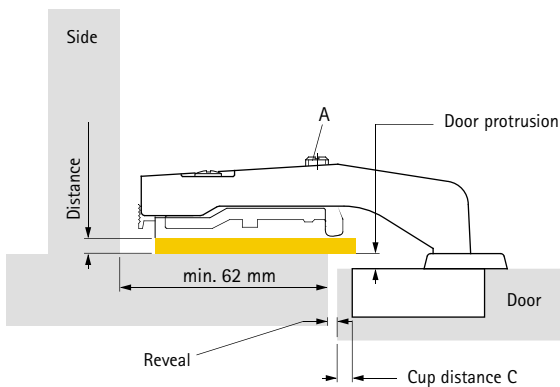

## Calculating distance

$$\text{Distance} = 5 \text{ mm} - \text{door protrusion}$$

The hinges are adjusted correctly ex factory.  
 The door protrusion can be adjusted if necessary.  
 Turn screw (A) clockwise:  
 The door protrusion can be adjusted by up to 6 mm (+2 mm/-4 mm).

The back of the door and front panel will be flush if a mounting plate with distance 5mm is used.

\* The hole distance X, cup distance C and the reveal must always add up to 28!

$$X + \text{cup distance C} + \text{reveal} = 28$$

## Calculating hole distance "X"

| Cup distance<br>C mm | Reveal mm |      |      |      |      |      |      |
|----------------------|-----------|------|------|------|------|------|------|
|                      | 0         | 0,5  | 1,0  | 1,5  | 2,0  | 2,5  | 3,0  |
| 3                    | 25,0      | 24,5 | 24,0 | 23,5 | 23,0 | 22,5 | 22,0 |
| 3,5                  | 24,5      | 24,0 | 23,5 | 23,0 | 22,5 | 22,0 | 21,5 |
| 4                    | 24,0      | 23,5 | 23,0 | 22,5 | 22,0 | 21,5 | 21,0 |
| 4,5                  | 23,5      | 23,0 | 22,5 | 22,0 | 21,5 | 21,0 | 20,5 |
| 5                    | 23,0      | 22,5 | 22,0 | 21,5 | 21,0 | 20,5 | 20,0 |
| 5,5                  | 22,5      | 22,0 | 21,5 | 21,0 | 20,5 | 20,0 | 19,5 |
| 6                    | 22,0      | 21,5 | 21,0 | 20,5 | 20,0 | 19,5 | 19,0 |
| 7                    | 21,0      | 20,5 | 20,0 | 19,5 | 19,0 | 18,5 | 18,0 |
| 8                    | 20,0      | 19,5 | 19,0 | 18,5 | 18,0 | 17,5 | 17,0 |

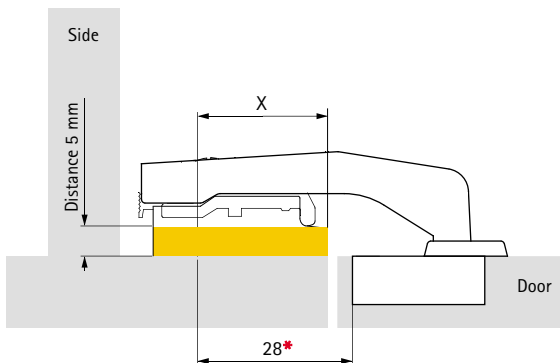

# Intermat 9944 W-30

## Fast-assembly hinge for negative face angle

### Opening angle 125°

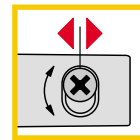
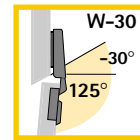

**Concealed hinge, snap-on assembly, integrated door overlay and eccentric depth adjustment.**

Opening angle 125°, cup diameter 35 mm.

For corner cupboards and cabinets with -30° face angle.

Intermat 9944 W-30 hinges are snapped onto the mounting plate.

Depth adjustment via eccentric screw -0,5 mm/+3,5 mm.

Height adjustment via mounting plate +2 mm/-2 mm, see pages 3.110 - 3.112.

Cup fixing screw  $\varnothing$  3,5 x 13 mm nickel-plated, for cup T 42

Order no. 048 296, PU 200

#### Cup version

**Cup T 42**  
Screw-on  
Nickel-plated  
steel

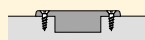

**Cup T 43**  
Press-in  
Nickel-plated  
steel



**Cup TB 43**  
Press-in  
Nickel-plated  
steel

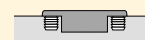

**Cup Flash**  
Fast-assembly  
Nickel-plated  
steel



#### Hinge version

Cranking 12 mm



#### Mounting option

Full overlay

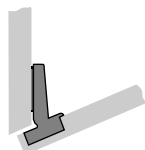

#### Article/order number

##### Intermat 9944 W-30

- self-closing

Packaging unit 50 pcs

● 9944 W-30  
T 42  
**073 936**

● 9944 W-30  
T 43  
**073 937**

● 9944 W-30  
TB 43  
**073 938**

● 9944 W-30  
Flash  
**073 939**

#### Mounting example

Intermat 9944 W-30  
Full overlay

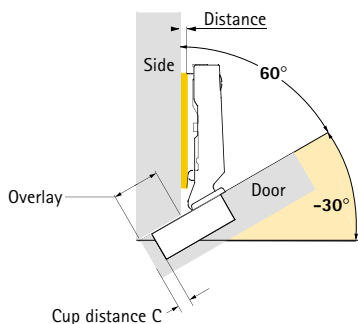

## Specification

Hettich Intermat 9944 W-30  
 Snap-on assembly  
 Eccentric depth adjustment  
 for negative face angle (-30°)  
 Opening angle 125°

### Cover cap for Intermat hinges

Nickel-plated steel  
**Order no. 013 300**  
 Black plastic  
**Order no. 048 043**  
 PU = 50 pcs

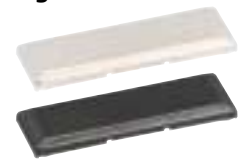

| Cup distance<br>C mm   | Door thickness mm |     |     |     |     |     |     |     |     |     |     |     |     |
|--|-------------------|-----|-----|-----|-----|-----|-----|-----|-----|-----|-----|-----|-----|
|  | 16                | 17  | 18  | 19  | 20  | 21  | 22  | 23  | 24  | 25  | 26  | 27  | 28  |
| <b>Minimum reveal per door – allow for in distance calculation</b> |                   |     |     |     |     |     |     |     |     |     |     |     |     |
| Table entries apply to doors with 0 mm radius                      |                   |     |     |     |     |     |     |     |     |     |     |     |     |
| 3  | 1,3               | 1,6 | 1,9 | 2,3 | 2,8 | 3,3 | 3,9 | 4,6 | 5,3 | 6,1 | 6,9 | 7,7 | 8,6 |
| 4  | 1,3               | 1,6 | 1,9 | 2,3 | 2,7 | 3,1 | 3,7 | 4,3 | 5,0 | 5,7 | 6,5 | 7,3 | 8,1 |
| 4,5  | 1,2               | 1,5 | 1,8 | 2,2 | 2,6 | 3,0 | 3,6 | 4,2 | 4,9 | 5,6 | 6,4 | 7,2 | 7,9 |
| 5  | 1,2               | 1,5 | 1,8 | 2,1 | 2,6 | 3,0 | 3,5 | 4,1 | 4,8 | 5,5 | 6,2 | 6,9 | 7,7 |
| 5,5  | 1,2               | 1,5 | 1,8 | 2,1 | 2,5 | 2,9 | 3,4 | 4,0 | 4,6 | 5,3 | 6,0 | 6,7 | 7,4 |

#### Note:

Drawings on this page are to full scale and show the hinges plus mounting plate distances. By drawing in the required cup distance C (3-5,5 mm), the door overlay can be measured directly from the applicable distance line.

The distance from the **cabinet front edge to X** on the selected distance line is also equal to the hole line distance from the cabinet front edge.

The minimum reveal is reduced for doors with radii: 1 mm radius: table entry – 0,4 mm  
 3 mm radius: table entry – 1,2 mm

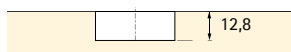
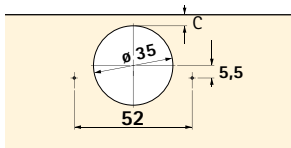

T42 hole dimensions

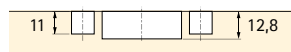
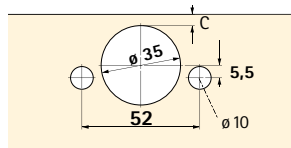

T43 / Flash hole dimensions

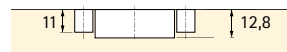
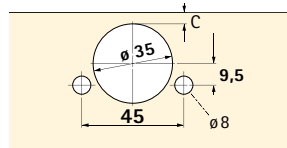

TB43 hole dimensions

#### Full overlay

\* Overlay adjustment +0,5 mm / -4 mm

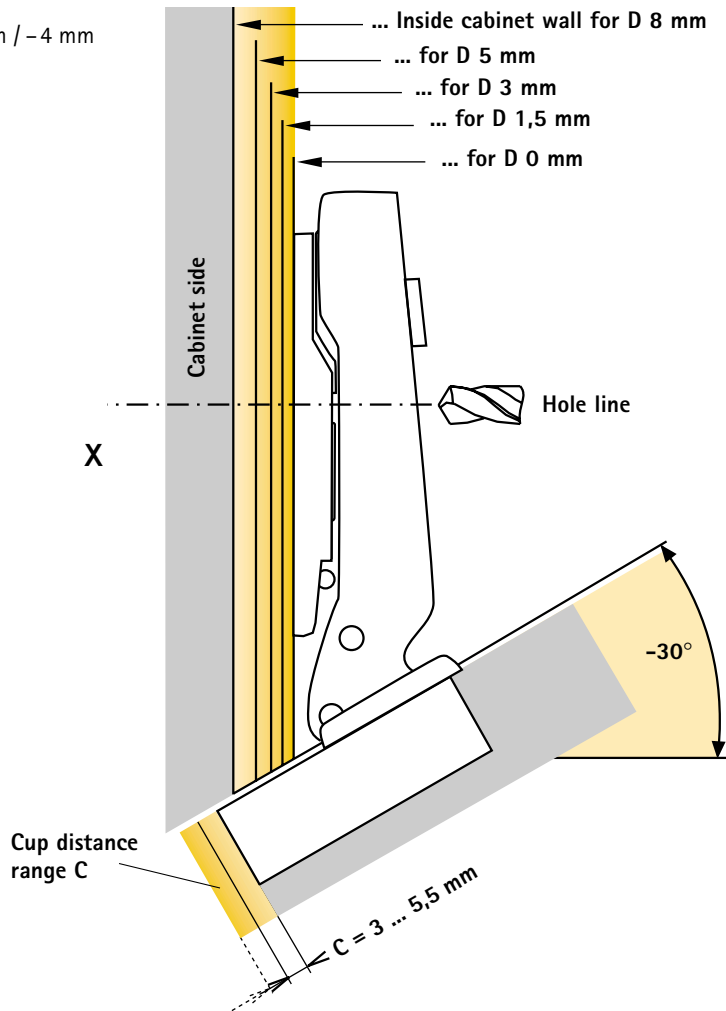

Scale 1:1

# Intermat 9944 W-30 FIX

## Toolless fast-assembly for negative face angles

### Opening angle 125°

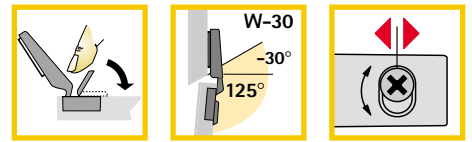

Concealed hinge, snap-on assembly plus toolless cup assembly, integrated door overlay and eccentric depth adjustment.

Opening angle 125°, cup diameter 35 mm.

For corner cupboards and cabinets with -30° face angle.

Intermat 9944 W-30 FIX are snapped onto the mounting plate and also feature toolless cup assembly.

Depth adjustment via eccentric screw -0,5 mm/+3,5 mm.

Height adjustment via mounting plate +2 mm/-2 mm, see pages 3.110 - 3.112.

#### Cup version

**Cup T FIX**  
Toolless  
Nickel-plated steel

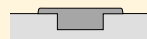

**Cup TH FIX**  
Toolless  
with pegs  
Nickel-plated steel



**Cup TB FIX**  
Toolless  
with pegs  
Nickel-plated steel



#### Hinge version

Cranking 12 mm



#### Mounting option

Full overlay

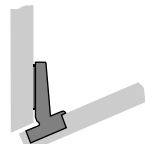

#### Article/order number

##### Intermat 9944 W-30 FIX

- self-closing

Packaging unit 50 pcs

● 9944 W-30 -  
T FIX  
077 717

● 9944 W-30 -  
TH FIX  
077 718

● 9944 W-30 -  
TB FIX  
077 719

#### Mounting example Intermat 9944 W-30 FIX Full overlay

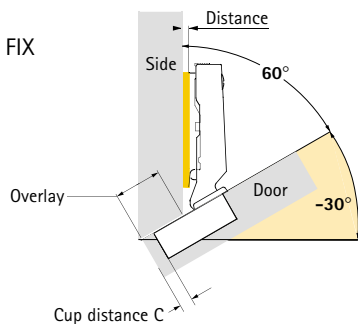

### Specification

Hettich Intermat 9944 W-30 FIX  
 Snap-on assembly plus toolless cup assembly  
 Eccentric depth adjustment  
 for negative face angle (-30°)  
 Opening angle 125°

### Cover cap for Intermat hinges

Nickel-plated steel  
**Order no. 013 300**  
 Black plastic  
**Order no. 048 043**  
 PU = 50 pcs



| Cup distance<br>C mm  | Door thickness mm |     |     |     |     |     |     |     |     |     |     |     |     |  |
|---|-------------------|-----|-----|-----|-----|-----|-----|-----|-----|-----|-----|-----|-----|--|
|   | 16                | 17  | 18  | 19  | 20  | 21  | 22  | 23  | 24  | 25  | 26  | 27  | 28  |  |
| Minimum reveal per door – allow for in distance calculation |                   |     |     |     |     |     |     |     |     |     |     |     |     |  |
| Table entries apply to doors with 0 mm radius               |                   |     |     |     |     |     |     |     |     |     |     |     |     |  |
| 3   | 1,3               | 1,6 | 1,9 | 2,3 | 2,8 | 3,3 | 3,9 | 4,6 | 5,3 | 6,1 | 6,9 | 7,7 | 8,6 |  |
| 4   | 1,3               | 1,6 | 1,9 | 2,3 | 2,7 | 3,1 | 3,7 | 4,3 | 5,0 | 5,7 | 6,5 | 7,3 | 8,1 |  |
| 4,5   | 1,2               | 1,5 | 1,8 | 2,2 | 2,6 | 3,0 | 3,6 | 4,2 | 4,9 | 5,6 | 6,4 | 7,2 | 7,9 |  |
| 5   | 1,2               | 1,5 | 1,8 | 2,1 | 2,6 | 3,0 | 3,5 | 4,1 | 4,8 | 5,5 | 6,2 | 6,9 | 7,7 |  |
| 5,5   | 1,2               | 1,5 | 1,8 | 2,1 | 2,5 | 2,9 | 3,4 | 4,0 | 4,6 | 5,3 | 6,0 | 6,7 | 7,4 |  |

### Note:

Drawings on this page are to full scale and show the hinges plus mounting plate distances. By drawing in the required cup distance C (3-5,5 mm), the door overlay can be measured directly from the applicable distance line.

The distance from the **cabinet front edge to X** on the selected distance line is also equal to the hole line distance from the cabinet front edge.

The minimum reveal is reduced for doors with radii: 1 mm radius: table entry – 0,4 mm  
 3 mm radius: table entry – 1,2 mm

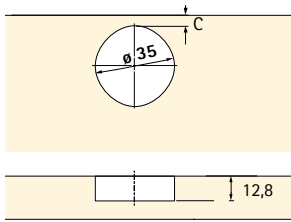

T FIX hole dimensions

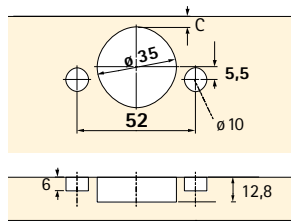

TH FIX hole dimensions

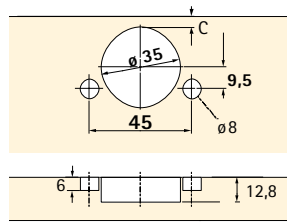

TB FIX hole dimensions

### Full overlay

\* Overlay adjustment +0,5 mm / -4 mm

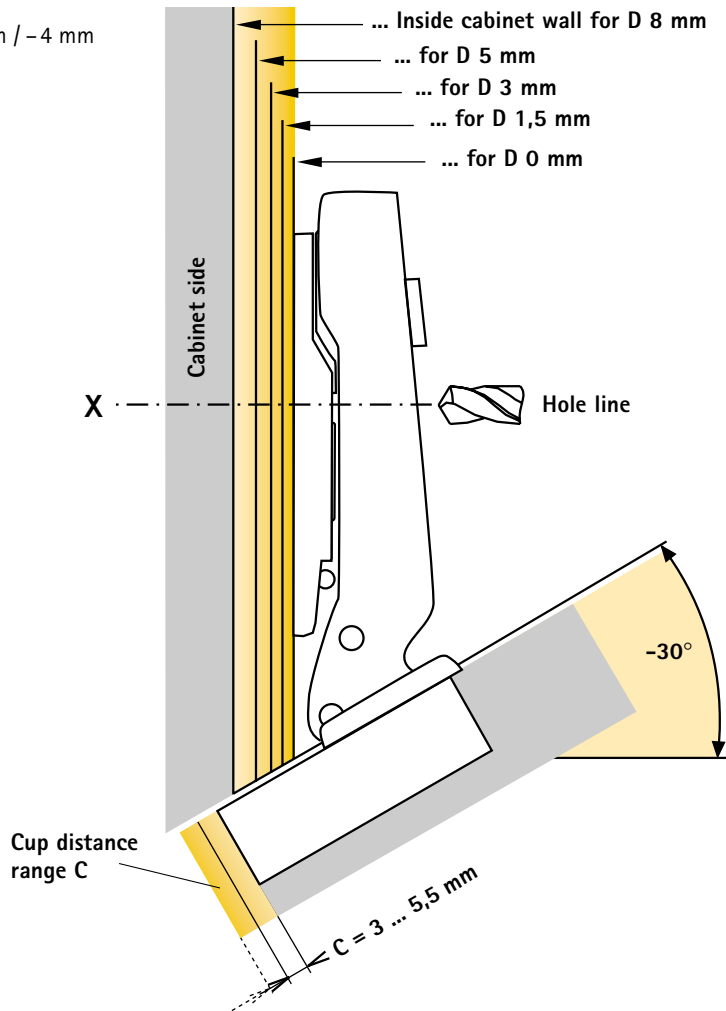

Scale 1:1

# Intermat 9944 W-45

## Fast-assembly hinge for negative face angle

### Opening angle 125°

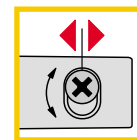
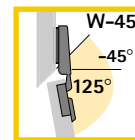

**Concealed hinge, snap-on assembly, integrated door overlay and eccentric depth adjustment.**

Opening angle 125°, cup diameter 35 mm.

For corner cupboards and cabinets with -45° face angle.

Interimat 9944 W-45 hinges are snapped onto the mounting plate.

Depth adjustment via eccentric screw -0,5 mm/+3,5 mm.

Height adjustment via mounting plate +2 mm/-2 mm, see pages 3.110 - 3.112.

Cup fixing screw  $\varnothing$  3,5 x 13 mm nickel-plated, for cup T 42

Order no. 048 296, PU 200

#### Cup version

**Cup T 42**  
Screw-on  
Nickel-plated steel

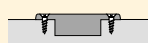

**Cup T 43**  
Press-in  
Nickel-plated steel

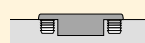

**Cup TB 43**  
Press-in  
Nickel-plated steel

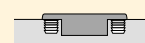

**Cup Flash**  
Fast-assembly  
Nickel-plated steel

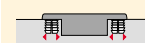

#### Hinge version

Cranking 10 mm



#### Mounting option

Full overlay

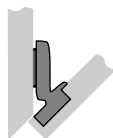

#### Article/order number

##### Interimat 9944 W-45

● self-closing

Packaging unit 50 pcs

● 9944 W-45  
T 42  
077 643

● 9944 W-45  
T 43  
077 720

● 9944 W-45  
TB 43  
077 721

● 9944 W-45  
Flash  
079 305

#### Mounting example

Interimat 9944 W-45  
Full overlay

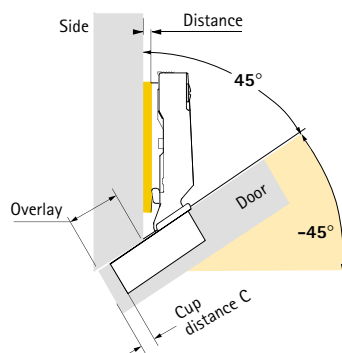

## Specification

Hettich Intermat 9944 W-45  
 Snap-on technology  
 Eccentric depth adjustment  
 for negative face angle (-45°)  
 Opening angle 125°

### Cover cap for Intermat hinges

Nickel-plated steel  
**Order no. 013 300**  
 Black plastic  
**Order no. 048 043**  
 PU = 50 pcs



| Cup distance<br>C mm   | Door thickness mm |     |     |     |     |     |     |     |     |     |     |     |     |
|--|-------------------|-----|-----|-----|-----|-----|-----|-----|-----|-----|-----|-----|-----|
|  | 16                | 17  | 18  | 19  | 20  | 21  | 22  | 23  | 24  | 25  | 26  | 27  | 28  |
| <b>Minimum reveal per door – allow for in distance calculation</b> |                   |     |     |     |     |     |     |     |     |     |     |     |     |
| Table entries apply to doors with 0 mm radius                      |                   |     |     |     |     |     |     |     |     |     |     |     |     |
| 3  | 1,3               | 1,6 | 1,9 | 2,3 | 2,8 | 3,3 | 3,9 | 4,6 | 5,3 | 6,1 | 6,9 | 7,7 | 8,6 |
| 4  | 1,3               | 1,6 | 1,9 | 2,3 | 2,7 | 3,1 | 3,7 | 4,3 | 5,0 | 5,7 | 6,5 | 7,3 | 8,1 |
| 4,5  | 1,2               | 1,5 | 1,8 | 2,2 | 2,6 | 3,0 | 3,6 | 4,2 | 4,9 | 5,6 | 6,4 | 7,2 | 7,9 |
| 5  | 1,2               | 1,5 | 1,8 | 2,1 | 2,6 | 3,0 | 3,5 | 4,1 | 4,8 | 5,5 | 6,2 | 6,9 | 7,7 |
| 5,5  | 1,2               | 1,5 | 1,8 | 2,1 | 2,5 | 2,9 | 3,4 | 4,0 | 4,6 | 5,3 | 6,0 | 6,7 | 7,4 |

#### Note:

Drawings on this page are to full scale and show the hinges plus mounting plate distances. By drawing in the required cup distance C (3-5,5 mm), the door overlay can be measured directly from the applicable distance line.

The distance from the **cabinet front edge to X** on the selected distance line is also equal to the hole line distance from the cabinet front edge.

The minimum reveal is reduced for doors with radii: 1 mm radius: table entry – 0,4 mm  
 3 mm radius: table entry – 1,2 mm

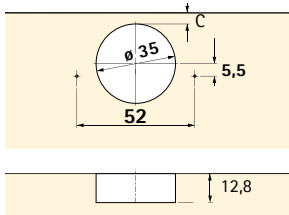

T42 hole dimensions

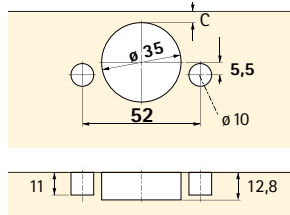

T43 / Flash hole dimensions

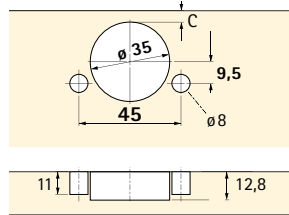

TB43 hole dimensions

#### Full overlay

\* Overlay adjustment +0,5 mm / -4 mm

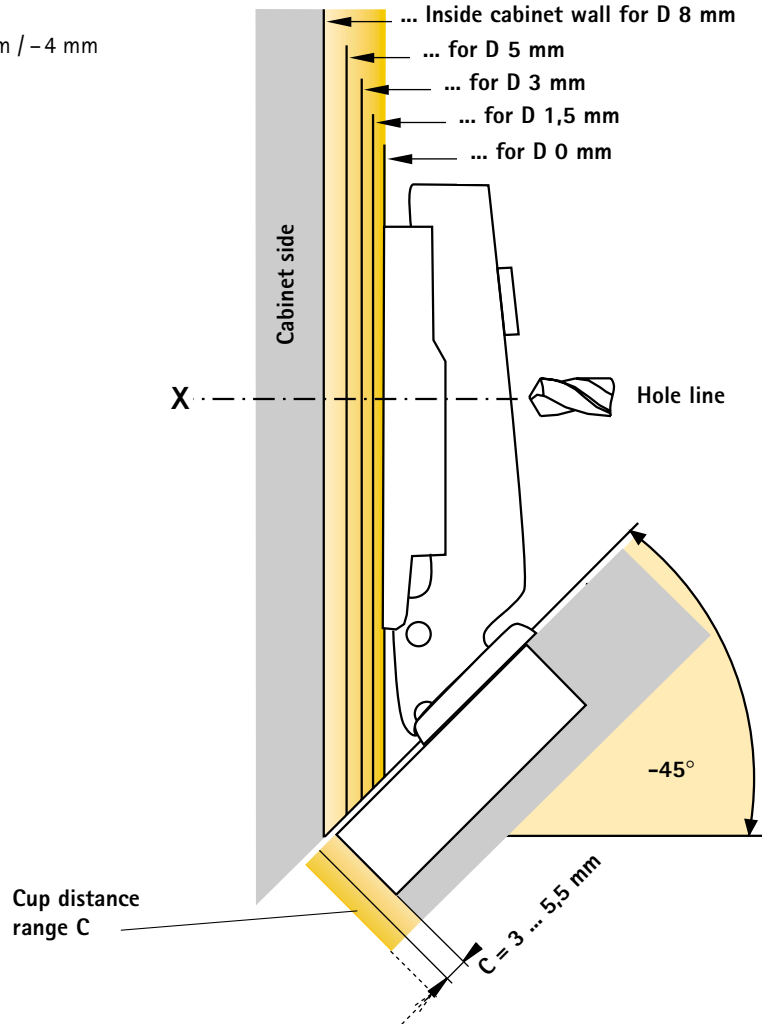

Scale 1:1

# Intermat 9944 W-45 FIX

## Toolless fast-assembly for negative face angles

### Opening angle 125°

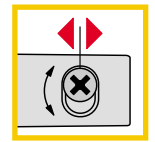
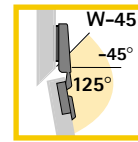
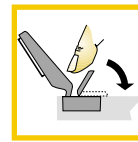

Concealed hinge, snap-on assembly plus toolless cup assembly, integrated door overlay and eccentric depth adjustment.

Opening angle 125°, cup diameter 35 mm.

For corner cupboards and cabinets with -45° face angle.

Intermat 9944 W-45 FIX are snapped onto the mounting plate and also feature toolless cup assembly.

Depth adjustment via eccentric screw -0,5 mm/+3,5 mm.

Height adjustment via mounting plate +2 mm/-2 mm, see pages 3.110 - 3.112.

#### Cup version

**Cup T FIX**  
Toolless  
Nickel-plated steel

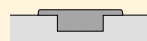

**Cup TH FIX**  
Toolless  
with pegs  
Nickel-plated steel

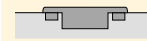

**Cup TB FIX**  
Toolless  
with pegs  
Nickel-plated steel

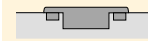

#### Hinge version

Cranking 10 mm



#### Mounting option

Full overlay

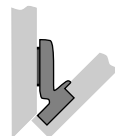

#### Article/order number

##### Intermat 9944 W-45 FIX

● self-closing

Packaging unit 50 pcs

● 9944 W-45-T FIX

077 722

● 9944 W-45-TH FIX

077 723

● 9944 W-45-TB FIX

077 724

#### Mounting example

Intermat 9944 W-45 FIX  
Full overlay

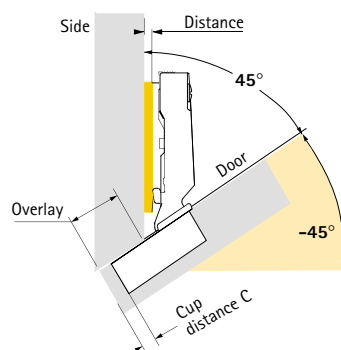

## Specification

Hettich Intermat 9944 W-45 FIX  
 Snap-on assembly plus toolless cup assembly  
 Eccentric depth adjustment  
 for negative face angles (-45°)  
 Opening angle 125°

### Cover cap for Intermat hinges

Nickel-plated steel  
**Order no. 013 300**  
 Black plastic  
**Order no. 048 043**  
 PU = 50 pcs

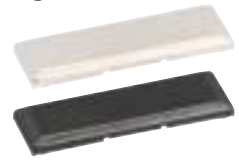

| Cup distance<br>C mm   | Door thickness mm |     |     |     |     |     |     |     |     |     |     |     |     |
|--|-------------------|-----|-----|-----|-----|-----|-----|-----|-----|-----|-----|-----|-----|
|  | 16                | 17  | 18  | 19  | 20  | 21  | 22  | 23  | 24  | 25  | 26  | 27  | 28  |
| <b>Minimum reveal per door – allow for in distance calculation</b> |                   |     |     |     |     |     |     |     |     |     |     |     |     |
| Table entries apply to doors with 0 mm radius                      |                   |     |     |     |     |     |     |     |     |     |     |     |     |
| 3  | 1,3               | 1,6 | 1,9 | 2,3 | 2,8 | 3,3 | 3,9 | 4,6 | 5,3 | 6,1 | 6,9 | 7,7 | 8,6 |
| 4  | 1,3               | 1,6 | 1,9 | 2,3 | 2,7 | 3,1 | 3,7 | 4,3 | 5,0 | 5,7 | 6,5 | 7,3 | 8,1 |
| 4,5  | 1,2               | 1,5 | 1,8 | 2,2 | 2,6 | 3,0 | 3,6 | 4,2 | 4,9 | 5,6 | 6,4 | 7,2 | 7,9 |
| 5  | 1,2               | 1,5 | 1,8 | 2,1 | 2,6 | 3,0 | 3,5 | 4,1 | 4,8 | 5,5 | 6,2 | 6,9 | 7,7 |
| 5,5  | 1,2               | 1,5 | 1,8 | 2,1 | 2,5 | 2,9 | 3,4 | 4,0 | 4,6 | 5,3 | 6,0 | 6,7 | 7,4 |

#### Note:

Drawings on this page are to full scale and show the hinges plus mounting plate distances. By drawing in the required cup distance C (3-5,5 mm), the door overlay can be measured directly from the applicable distance line.

The distance from the **cabinet front edge to X** on the selected distance line is also equal to the hole line distance from the cabinet front edge.

The minimum reveal is reduced for doors with radii: 1 mm radius: table entry – 0,4 mm  
 3 mm radius: table entry – 1,2 mm

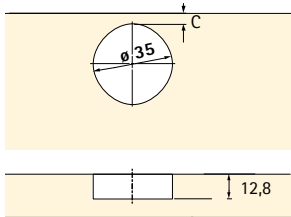

T FIX hole dimensions

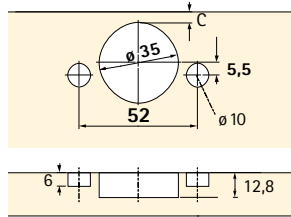

TH FIX hole dimensions

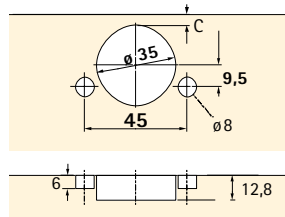

TB FIX hole dimensions

#### Full overlay

\* Overlay adjustment +0,5 mm / -4 mm

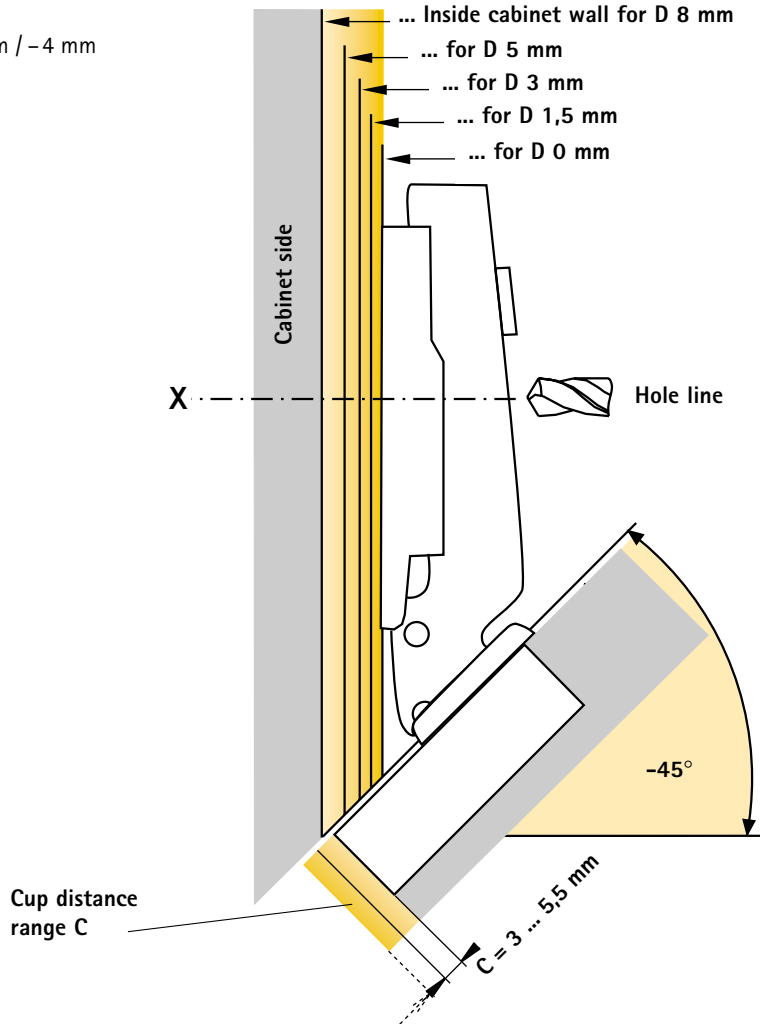

Scale 1:1

# Intermat 9924

## Fast-assembly hinge

### Cup diameter 26 mm

### Opening angle 95°

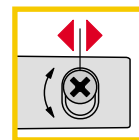
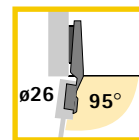

**Concealed hinges, snap-on assembly, integrated door overlay and eccentric depth adjustment.**

Opening angle 95°, cup diameter 26 mm.

For small doors and narrow frame doors.

Intermat 9924 hinges are snapped onto the mounting plate.

Depth adjustment via eccentric screw -0,5 mm/+3,5 mm.

Height adjustment via mounting plate +2 mm/-2 mm, see pages 3.110 - 3.112.

Cup fixing screw  $\varnothing$  3,5 x 13 mm nickel-plated, for cup T 42/26

Order no. 048 296, PU 200

#### Cup version

**Cup T 42/26**  
Screw-on  
Nickel-plated steel

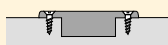

**Cup T 43/26**  
Press-in  
Nickel-plated steel

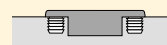

#### Hinge version

#### Mounting option

#### Article/order number

Cranking 1 mm

Full overlay

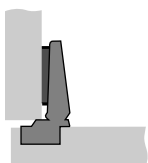

**Intermat 9924**  
● self-closing

Packaging unit 50 pcs

● 9924-  
T42/26  
072 959

● 9924-  
T43/26  
077 725

Cranking 9,5 mm

Half overlay

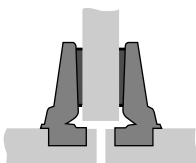

**Intermat 9924**  
● self-closing

Packaging unit 50 pcs

● 9924-  
T42/26  
072 965

● 9924-  
T43/26  
077 726

Cranking 16 mm

Inset

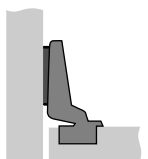

**Intermat 9924**  
● self-closing

Packaging unit 50 pcs

● 9924-  
T42/26  
072 966

● 9924-  
T43/26  
077 727

### Specification

Hettich Intermat 9924  
 Snap-on assembly, cup diameter 26 mm  
 Eccentric depth adjustment  
 for doors with narrow frames  
 Opening angle 95°

### Cover cap for Intermat hinges

Nickel-plated steel  
**Order no. 013 300**  
 Black plastic  
**Order no. 048 043**  
 PU = 50 pcs



| Cup distance<br>C mm   | Door thickness mm |     |     |     |     |     |     |     |     |     |     |
|--|-------------------|-----|-----|-----|-----|-----|-----|-----|-----|-----|-----|
|  | 15                | 16  | 17  | 18  | 19  | 20  | 21  | 22  | 23  | 24  | 25  |
| Minimum reveal per door – allow for in distance calculation<br>Table entries apply to doors with 0 mm radius |                   |     |     |     |     |     |     |     |     |     |     |
| 3  | 0,5               | 0,9 | 1,3 | 2,1 | 2,9 | 3,7 | 4,6 | 5,6 | 6,5 | 7,4 | 8,4 |
| 4  | 0,5               | 0,8 | 1,2 | 1,8 | 2,5 | 3,3 | 4,2 | 5,0 | 5,9 | 6,8 | 7,7 |
| 4,5  | 0,5               | 0,8 | 1,2 | 1,8 | 2,4 | 3,1 | 4,0 | 4,8 | 5,6 | 6,5 | 7,4 |
| 5  | 0,5               | 0,8 | 1,2 | 1,7 | 2,2 | 2,9 | 3,7 | 4,5 | 5,3 | 6,1 | 7,0 |
| 5,5  | 0,5               | 0,8 | 1,1 | 1,5 | 2,0 | 2,7 | 3,5 | 4,2 | 5,0 | 5,8 | 6,6 |

The minimum reveal is reduced for doors with radii: 1 mm radius: table entry – 0,4 mm  
 3 mm radius: table entry – 1,2 mm

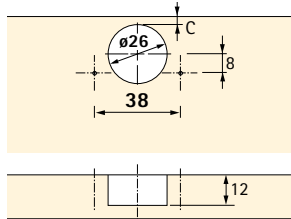

T42/26 hole dimensions

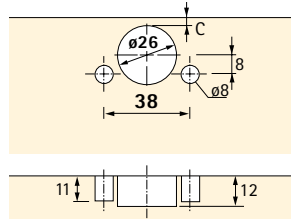

T43/26 hole dimensions

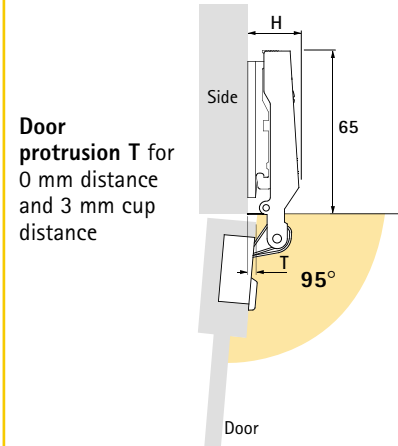

| Cranking mm | H mm | T mm |
|-------------|------|------|
| 1           | 19   | 3,2  |
| 9,5         | 23   | 12,7 |
| 16          | 29,5 | 19,2 |

3

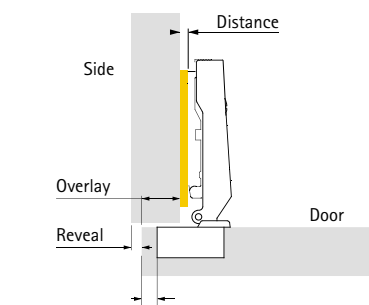

| Cup distance<br>C mm | Overlay mm |     |     |     |     |     |     |     |     |      |  |
|----------------------|------------|-----|-----|-----|-----|-----|-----|-----|-----|------|--|
|                      | 8          | 9   | 10  | 11  | 12  | 13  | 14  | 15  | 16  | 16,5 |  |
| Distance D mm        |            |     |     |     |     |     |     |     |     |      |  |
| 3                    | 6,0        | 5,0 | 4,0 | 3,0 | 2,0 | 1,0 | 0,0 |     |     |      |  |
| 4                    | 7,0        | 6,0 | 5,0 | 4,0 | 3,0 | 2,0 | 1,0 | 0,0 |     |      |  |
| 4,5                  | 7,5        | 6,5 | 5,5 | 4,5 | 3,5 | 2,5 | 1,5 | 0,5 |     |      |  |
| 5                    | 8,0        | 7,0 | 6,0 | 5,0 | 4,0 | 3,0 | 2,0 | 1,0 | 0,0 |      |  |
| 5,5                  | 8,5        | 7,5 | 6,5 | 5,5 | 4,5 | 3,5 | 2,5 | 1,5 | 0,5 | 0,0  |  |

\* Overlay adjustment – 4 mm, + 0,5 mm

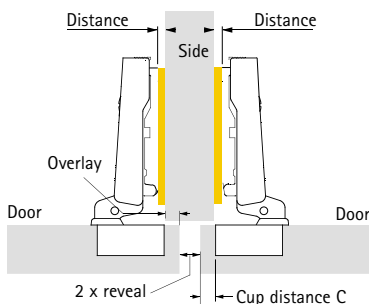

| Cup distance<br>C mm | Overlay mm |     |     |     |     |     |     |     |     |  |
|----------------------|------------|-----|-----|-----|-----|-----|-----|-----|-----|--|
|                      | 0          | 1   | 2   | 3   | 4   | 5   | 6   | 7   | 7,5 |  |
| Distance D mm        |            |     |     |     |     |     |     |     |     |  |
| 3                    | 5,5        | 4,5 | 3,5 | 2,5 | 1,5 | 0,5 |     |     |     |  |
| 4                    | 6,5        | 5,5 | 4,5 | 3,5 | 2,5 | 1,5 | 0,5 |     |     |  |
| 4,5                  | 7,0        | 6,0 | 5,0 | 4,0 | 3,0 | 2,0 | 1,0 | 0,0 |     |  |
| 5                    | 7,5        | 6,5 | 5,5 | 4,5 | 3,5 | 2,5 | 1,5 | 0,5 | 0,0 |  |
| 5,5                  | 8,0        | 7,0 | 6,0 | 5,0 | 4,0 | 3,0 | 2,0 | 1,0 | 0,5 |  |

\* Overlay adjustment – 4 mm, + 0,5 mm

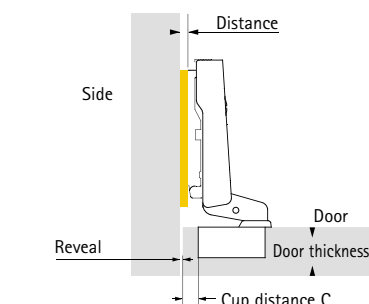

| Cup distance<br>C mm | Door thickness mm |     |     |     |     |     |     |     |     |     |     |
|----------------------|-------------------|-----|-----|-----|-----|-----|-----|-----|-----|-----|-----|
|                      | 15                | 16  | 17  | 18  | 19  | 20  | 21  | 22  | 23  | 24  | 25  |
| Distance D mm        |                   |     |     |     |     |     |     |     |     |     |     |
| 3                    |                   |     | 0,3 | 1,1 | 1,9 | 2,7 | 3,6 | 4,6 | 5,5 | 6,4 | 7,4 |
| 4                    | 0,5               | 0,8 | 1,2 | 1,8 | 2,5 | 3,3 | 4,2 | 5,0 | 5,9 | 6,8 | 7,7 |
| 4,5                  | 1,0               | 1,3 | 1,7 | 2,3 | 2,9 | 3,7 | 4,5 | 5,2 | 6,1 | 7,0 | 7,9 |
| 5                    | 1,5               | 1,8 | 2,2 | 2,7 | 3,2 | 3,9 | 4,7 | 5,5 | 6,3 | 7,1 | 8,0 |
| 5,5                  | 2,0               | 2,3 | 2,6 | 3,0 | 3,5 | 4,2 | 5,0 | 5,7 | 6,5 | 7,3 | 8,1 |

\* Reveal adjustment + 4 mm, – 0,5 mm

# Aluminium frame profile Width 45 mm for Intermat 9924 T42/26

Can be made up to custom dimensions or ready-made up



This profile can be customised to size by the customer.

- Silver anodised surface
- Usable with 4 and 5 mm glass thickness
- Can be cut to individually required lengths
- Safe installation with fixing angles and screw connection

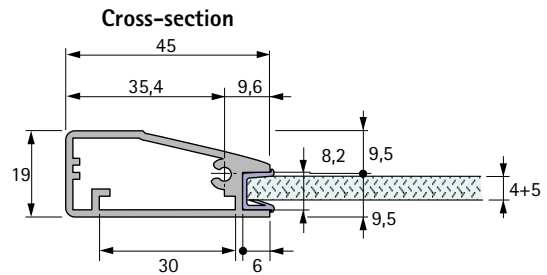

3

**Aluminium frame profile**  
silver anodised  
Length 3500 mm

**Sealing strip**  
for glass thickness 4 + 5 mm  
plastic, transparent  
Length 3500 mm

**Angle set**  
contains:  
4 fixing angles  
8 fixing screws



| Article                 | Order no. | PU | Article                                    | Order no. | PU | Article   | Order no. | PU    |
|-------------------------|-----------|----|--|-----------|----|-----------|-----------|-------|
| Aluminium frame profile | 075 619   | 1  | Sealing strip for glass thickness 4 + 5 mm | 075 620   | 1  | Angle set | 075 621   | 1 set |

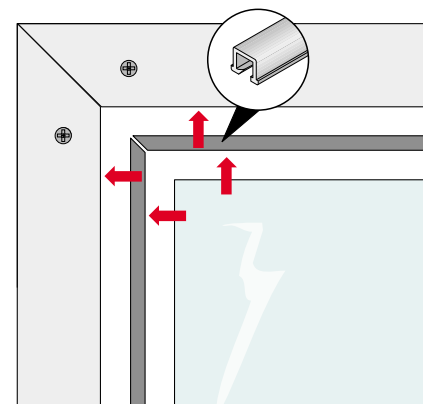
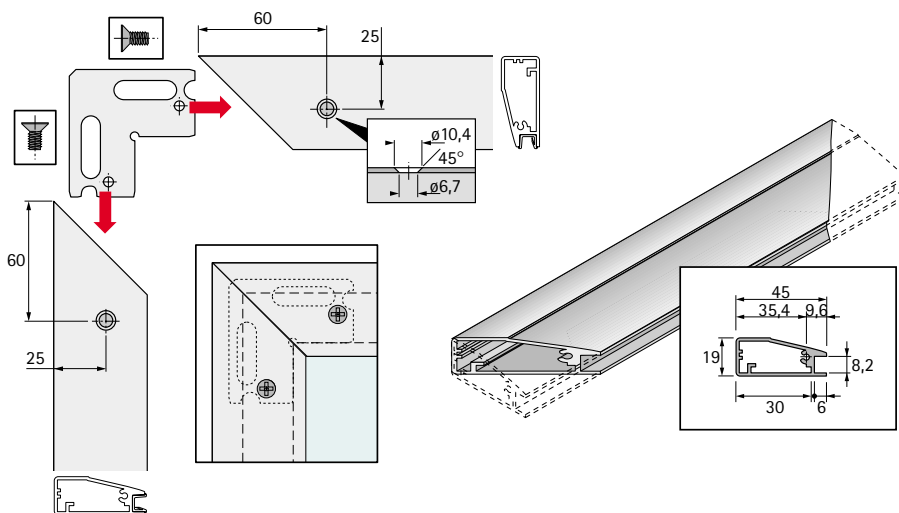

Hinge fastened with special cup screw  
ø 3.5 x 9.5  
see page 3.83

Glass cutting dimension =  
door width/height – 81 mm

# Fax order to your specialist retailer

Simply fill in the fax form to receive a set of aluminium frame profiles fully customised to your dimensions, width 45 mm

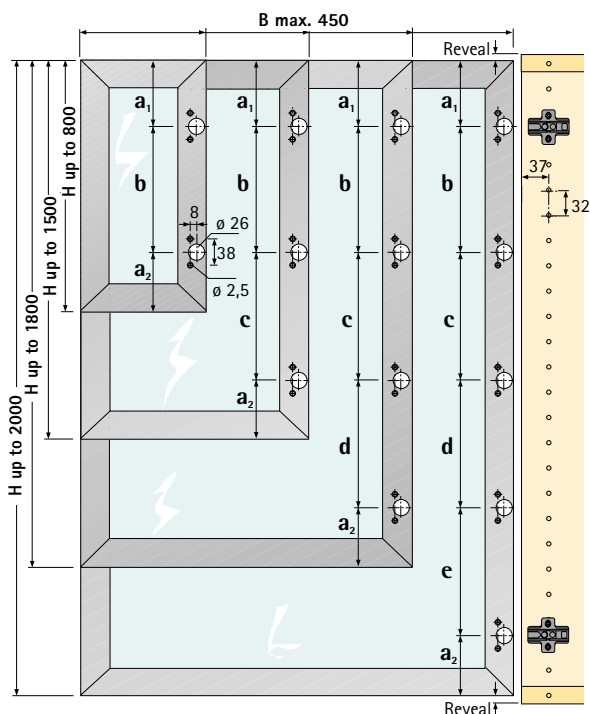

## Aluminium frame profile set, width 45 mm made to measure

contains: 4 aluminium frame profiles, silver anodised  
4 sealing profiles for 4 mm and 5 mm gauge glass

| Order no. | PU    | Door perimeter mm | Number of doors |
|-----------|-------|-------------------|-----------------|
| 041 282   | 1 set |                   |                 |

## Fabrication for an aluminium frame, width 45 mm

contains: mitre cuts, including cutting to length  
drill holes for mitre joint  
4 angle connectors  
8 countersunk screws

| Order no. | PU | Number of doors |
|-----------|----|-----------------|
| 041 286   | 1  |                 |

**Attention:** Use a separate order sheet for each frame size/door size.  
Please specify all measurements in mm!

|                                 | up to 800 | up to 1500 | up to 1800 | up to 2000 |
|---------------------------------|-----------|------------|------------|------------|
| <b>H</b>                        |           |            |            |            |
| <b>B</b><br>max. 450            |           |            |            |            |
| <b>a<sub>1</sub></b><br>min. 95 |           |            |            |            |
| <b>b</b>                        |           |            |            |            |
| <b>c</b>                        |           |            |            |            |
| <b>d</b>                        |           |            |            |            |
| <b>e</b>                        |           |            |            |            |
| <b>a<sub>2</sub></b><br>min. 95 |           |            |            |            |
| left<br>Number of doors         |           |            |            |            |
| right<br>Number of doors        |           |            |            |            |

## Fabrication for hinged doors

contains: 1 hinge drill hole  $\varnothing$  26 mm

| Order no. | PU | Order quantity* |
|-----------|----|-----------------|
| 041 291   | 1  |                 |

\* Number of hinge slots

Intermat 9924,  
opening angle 95°,  
cup diameter  
26 mm, T42

| Version  | Order no. | Stock    | Order quantity |
|--|-----------|----------|----------------|
| Cranking 0 mm, full overlay                      | 072 959   | Retailer |                |
| Cranking 9,5 mm, half overlay                    | 072 965   | Retailer |                |
| Cranking 16 mm, inset                            | 072 966   | Retailer |                |
| Special cup fixing screw $\varnothing$ 3,5 x 9,5 | 041 296   | Retailer |                |

Mounting plates and cover caps for Intermat hinges must be ordered separately

|                              |
|------------------------------|
| Joiner/interior fitter:      |
| Date: _____ Signature: _____ |

# Intermat 9904

## Fast-assembly hinge for glass doors

### Opening angle 95°

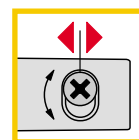
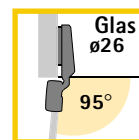

**Concealed glass door hinge, snap-on assembly, integrated door overlay and eccentric depth adjustment.**

Opening angle 95°, glass door hole diameter 26 mm.

For glass doors with panel thickness of 4 - 6,5 mm.

For a glass panel thickness from 5,5 mm, order 2 x cup fixing screws (order number 069 611, PU 1000).

Intermat 9904 hinges are snapped onto the mounting plate.

For various decorative caps, see page 3.85

Depth adjustment via eccentric screw -0,5 mm/+3,5 mm.

Height adjustment via mounting plate +2 mm/-2 mm, see pages 3.110 - 3.112.

#### Cup version

**Cup T1**  
Screw-on  
Black plastic



#### Hinge version

#### Mounting option

#### Article/order number

Cranking 1 mm

Full overlay

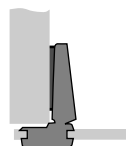

**Intermat 9904**  
● self-closing

Packaging unit 50 pcs

● 9904-T1  
**072 960**

Cranking 9,5 mm

Half overlay

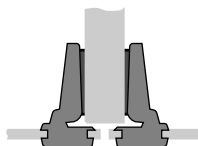

**Intermat 9904**  
● self-closing

Packaging unit 50 pcs

● 9904-T1  
**072 967**

Cranking 16 mm

Inset

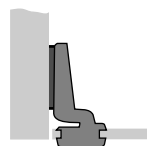

**Intermat 9904**  
● self-closing

Packaging unit 50 pcs

● 9904-T1  
**072 968**

### Specification

Hettich Intermat 9904

Snap-on assembly

Eccentric depth adjustment for glass doors

Glass door hole diameter 26 mm, glass thickness 4 - 6,5 mm

Opening angle 95°

### Cover cap for Intermat hinges

Nickel-plated steel

Order no. **013 300**

Black plastic

Order no. **048 043**

PU = 50 pcs

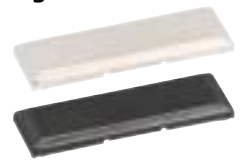

| Finish            | Order no. | PU | Finish            | Order no. | PU |
|-------------------|-----------|----|-------------------|-----------|----|
| high-gloss gold   | 040 340   | 50 | high-gloss gold   | 040 494   | 50 |
| high-gloss chrome | 040 341   | 50 | high-gloss chrome | 040 495   | 50 |
| black             | 070 051   | 50 | black             | 070 052   | 50 |
| matt nickel       | 070 712   | 50 | matt nickel       | 070 713   | 50 |
| metallic brown    | 040 342   | 50 |                   |           |    |

Decorative cap A



Decorative cap B

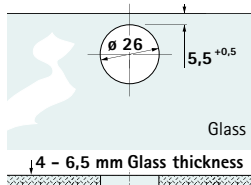

T1 hole dimensions

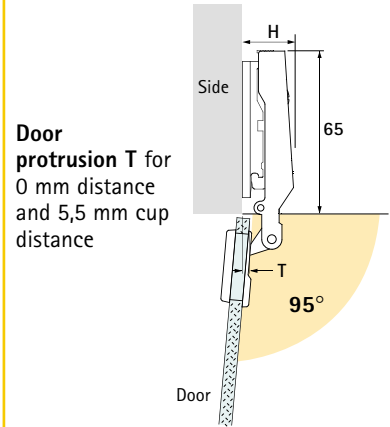

Door protrusion T for 0 mm distance and 5,5 mm cup distance

| Cranking mm | H mm | T mm |
|-------------|------|------|
| 1           | 19   | 3,0  |
| 9,5         | 23   | 12,5 |
| 16          | 29,5 | 19,0 |

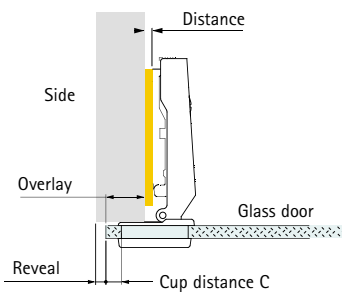

| Cup distance C-distance | Overlay mm |     |     |     |     |     |     |     |      |  |
|-------------------------|------------|-----|-----|-----|-----|-----|-----|-----|------|--|
|                         | 9          | 10  | 11  | 12  | 13  | 14  | 15  | 16  | 16,5 |  |
| 5,5                     | 7,5        | 6,5 | 5,5 | 4,5 | 3,5 | 2,5 | 1,5 | 0,5 | 0    |  |

\* Overlay adjustment - 4 mm, + 0,5 mm

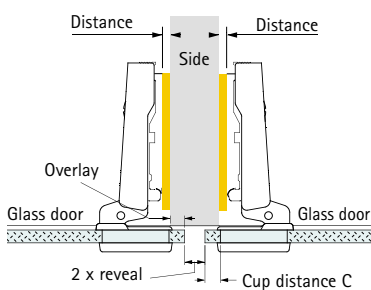

| Cup distance C mm | Overlay mm |     |     |     |     |     |     |     |     |     |
|-------------------|------------|-----|-----|-----|-----|-----|-----|-----|-----|-----|
|                   | 0          | 1   | 2   | 3   | 4   | 5   | 6   | 7   | 7,5 | 8   |
| 5,5               | 8,0        | 7,0 | 6,0 | 5,0 | 4,0 | 3,0 | 2,0 | 1,0 | 0,5 | 0,0 |

\* Overlay adjustment - 4 mm, + 0,5 mm

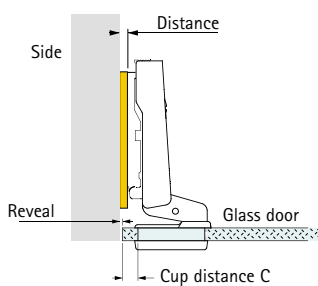

Reveal = 1,5 mm  
Cup distance = 5,5 mm  
Distance = 3,0 mm

\* Reveal adjustment + 4 mm, - 0,5 mm

# Intermat 9924 W30

## Fast-assembly hinge for corner cabinets

### Cup diameter 26 mm

### Opening angle 95°

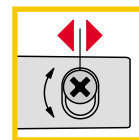
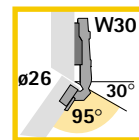

**Concealed hinge, snap-on assembly, integrated door overlay and eccentric depth adjustment.**

Opening angle 95°, cup diameter 26 mm.

For small doors and narrow frame doors for corner cabinets with 30° face angles.

Intermat 9924 W30 hinges are clipped onto the mounting plate.

Depth adjustment via eccentric screw -0,5 mm/+3,5 mm.

Height adjustment via mounting plate +2 mm/-2 mm, see pages 3.110 - 3.112.

Cup fixing screw  $\varnothing$  3,5 x 13 mm nickel-plated, for cup T 42/26

Order no. 048 296, PU 200

#### Cup version

**Cup T 42/26**  
Screw-on  
Nickel-plated steel

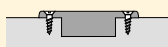

**Cup T 43/26**  
Press-in  
Nickel-plated steel

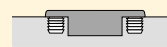

#### Hinge version

#### Mounting option

#### Article/order number

Cranking 6 mm

Full overlay

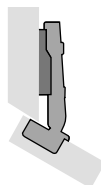

**Intermat 9924 W30**  
● self-closing

**Packaging unit 50 pcs**

● 9924 W30-T42/26  
**079 306**

● 9924 W30-T43/26  
**079 308**

Cranking - 5 mm

Inset

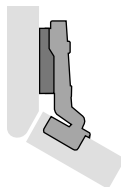

**Intermat 9924 W30**  
● self-closing

**Packaging unit 50 pcs**

● 9924 W30-T42/26  
**079 307**

● 9924 W30-T43/26  
**079 309**

**Mounting example**  
Intermat 9924 W30  
Full overlay

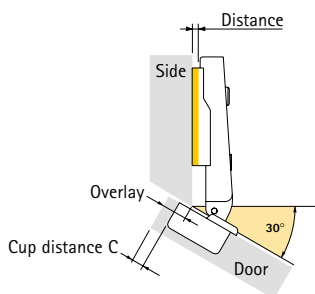

**Mounting example**  
Intermat 9924 W30  
Inset

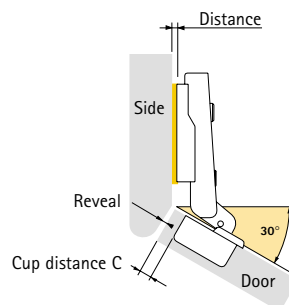

## Specification

Hettich Intermat 9924 W30  
 Snap-on assembly and eccentric depth adjustment  
 Cup diameter 26 mm for 30° corner cabinets  
 and doors with narrow door frames  
 Opening angle 95°

### Cover cap for Intermat hinges

Nickel-plated steel  
**Order no. 013 300**  
 Black plastic  
**Order no. 048 043**  
 PU = 50 pcs

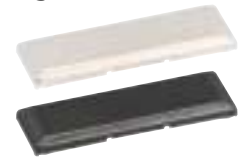

| Cup distance<br>C mm   | Door thickness mm |     |     |     |     |     |     |     |     |     |     |
|--|-------------------|-----|-----|-----|-----|-----|-----|-----|-----|-----|-----|
|  | 15                | 16  | 17  | 18  | 19  | 20  | 21  | 22  | 23  | 24  | 25  |
| Minimum reveal per door – allow for in distance calculation<br>Table entries apply to doors with 0 mm radius |                   |     |     |     |     |     |     |     |     |     |     |
| 3  | 0,5               | 0,9 | 1,3 | 2,1 | 2,9 | 3,7 | 4,6 | 5,6 | 6,5 | 7,4 | 8,4 |
| 4  | 0,5               | 0,8 | 1,2 | 1,8 | 2,5 | 3,3 | 4,2 | 5,0 | 5,9 | 6,8 | 7,7 |
| 4,5  | 0,5               | 0,8 | 1,2 | 1,8 | 2,4 | 3,1 | 4,0 | 4,8 | 5,6 | 6,5 | 7,4 |
| 5  | 0,5               | 0,8 | 1,2 | 1,7 | 2,2 | 2,9 | 3,7 | 4,5 | 5,3 | 6,1 | 7,0 |
| 5,5  | 0,5               | 0,8 | 1,1 | 1,5 | 2,0 | 2,7 | 3,5 | 4,2 | 5,0 | 5,8 | 6,6 |

#### Note:

Drawings on this page are to full scale and show the hinges plus mounting plate distances. By drawing in the required cup distance C (3–5,5 mm), the door overlay can be measured directly from the applicable distance line.

The distance from the **cabinet front edge to X** on the selected distance line is also equal to the hole line distance from the cabinet front edge.

For **inset-mounted** doors, the cup distance and door thickness must be taken into account when determining the **minimum door reveal**.

The minimum reveal is reduced for doors with radii: 1 mm radius: table entry – 0,4 mm  
 3 mm radius: table entry – 1,2 mm

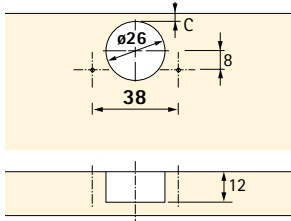

T42/26 hole dimensions

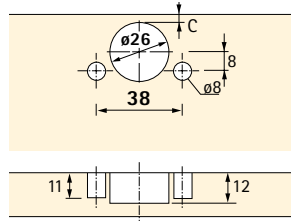

T43/26 hole dimensions

#### Full overlay

\* Overlay adjustment +0,5 mm / –3 mm

#### Inset

\* Reveal adjustment –0,5 mm / +3 mm

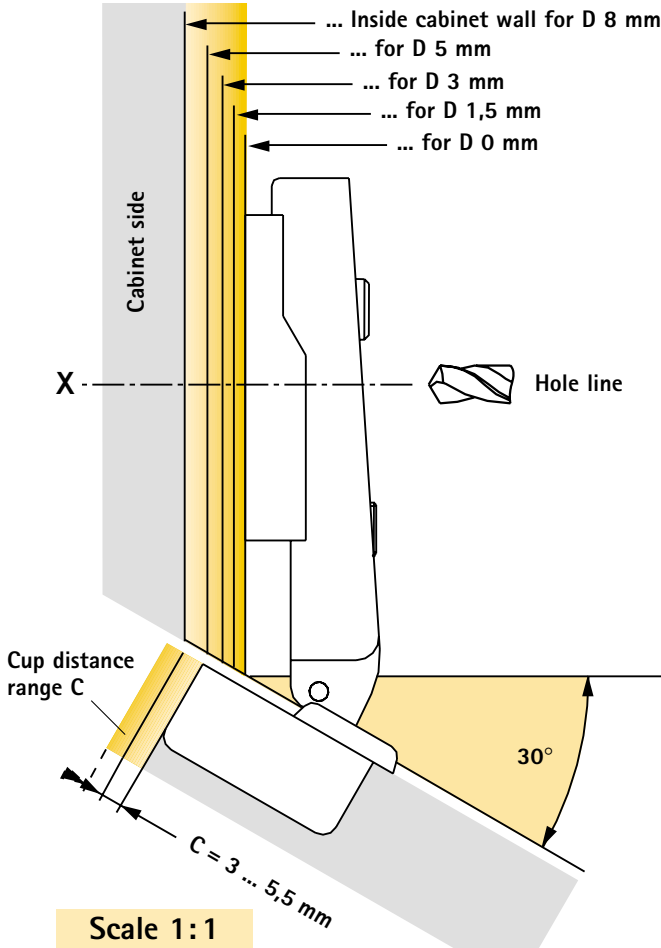

Scale 1:1

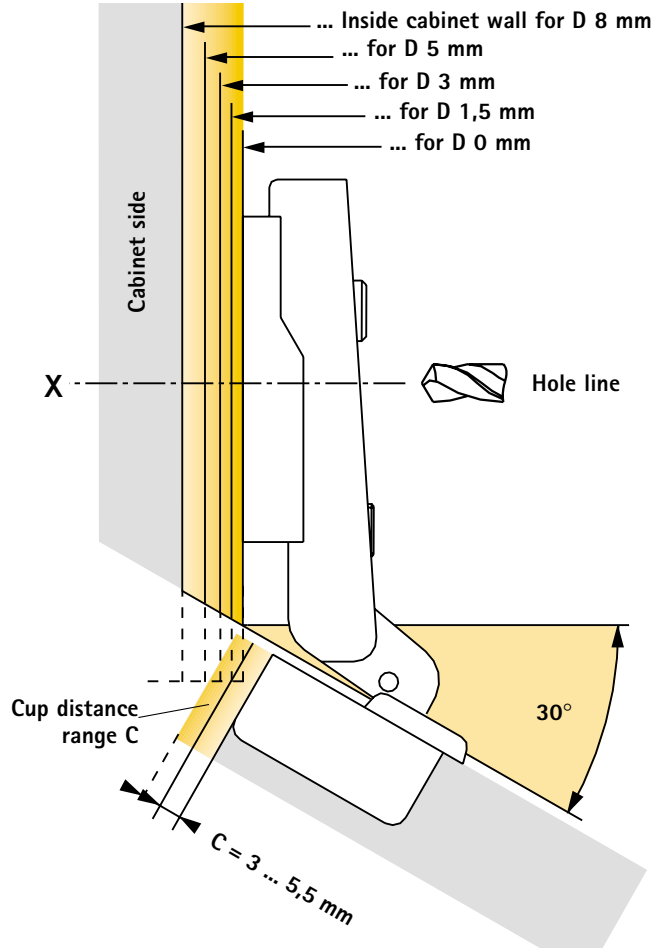

# Intermat 9904 W30

## Fast-assembly glass door hinge for corner cabinets

Cup diameter 26 mm  
Opening angle 95°

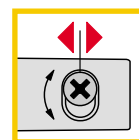
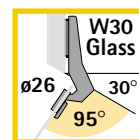

**Concealed glass door hinge, snap-on assembly, integrated door overlay and eccentric depth adjustment.**

Opening angle 95°, glass door hole diameter 26 mm.

For corner cupboards and cabinets with 30° face angle and glass doors with panel thickness of 4 - 6,5 mm.

For a glass panel thickness from 5,5 mm, order 2 x cup fixing screws (order number 069 611, PU 1000).

Intermat 9904 W30 hinges are snapped onto the mounting plate.

For various decorative caps, see page 3.89.

Depth adjustment via eccentric screw -0,5 mm/+3,5 mm.

Height adjustment via mounting plate +2 mm/-2 mm, see pages 3.110 - 3.112.

### Cup version

**Cup T 1**  
Screw-on  
Black plastic



### Hinge version

### Mounting option

### Article/order number

Cranking 6 mm

Full overlay

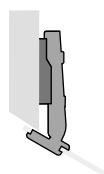

**Intermat 9904 W30**

- self-closing

**Packaging unit 50 pcs**

● **9904 W30-T1**  
**079 314**

Cranking - 5 mm

Inset

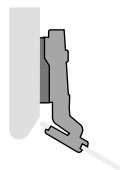

**Intermat 9904 W30**

- self-closing

**Packaging unit 50 pcs**

● **9904 W30-T1**  
**079 315**

### Mounting example Intermat 9904 W30 Full overlay

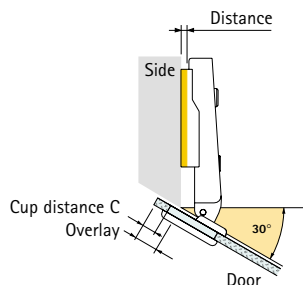

### Mounting example Intermat 9904 W30 Inset

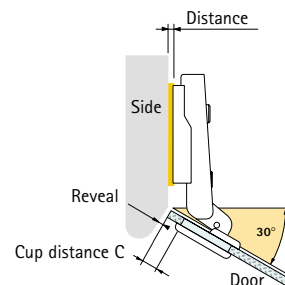

## Specification

Hettich Intermat 9904 W30

Snap-on assembly and eccentric depth adjustment for glass doors with 30° corners

Glass door hole diameter 26 mm, glass thickness 4 - 6,5 mm

Opening angle 95°

### Cover cap for Intermat hinges

Nickel-plated steel

Order no. **013 300**

Black plastic

Order no. **048 043**

PU = 50 pcs



| Finish            | Order no. | PU | Finish            | Order no. | PU |
|-------------------|-----------|----|-------------------|-----------|----|
| high-gloss gold   | 040 340   | 50 | high-gloss gold   | 040 494   | 50 |
| high-gloss chrome | 040 341   | 50 | high-gloss chrome | 040 495   | 50 |
| black             | 070 051   | 50 | black             | 070 052   | 50 |
| matt nickel       | 070 712   | 50 | matt nickel       | 070 713   | 50 |
| metallic brown    | 040 342   | 50 |                   |           |    |

Decorative cap A



Decorative cap B

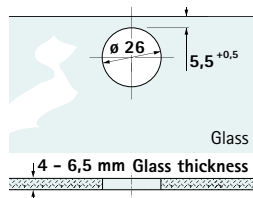

T1 hole dimensions

#### Note:

Drawings on this page are to full scale and show the hinges plus mounting plate distances. By drawing in the required cup distance  $C = 5,5$  mm the door overlay can be measured directly from the applicable distance line.

The distance from the **cabinet front edge to X** on the selected distance line is also equal to the hole line distance from the cabinet front edge.

For **inset-mounted** doors, the cup distance and door thickness must be taken into account when determining the **minimum reveal**.

#### Full overlay

\* Overlay adjustment +0,5 mm / -3 mm

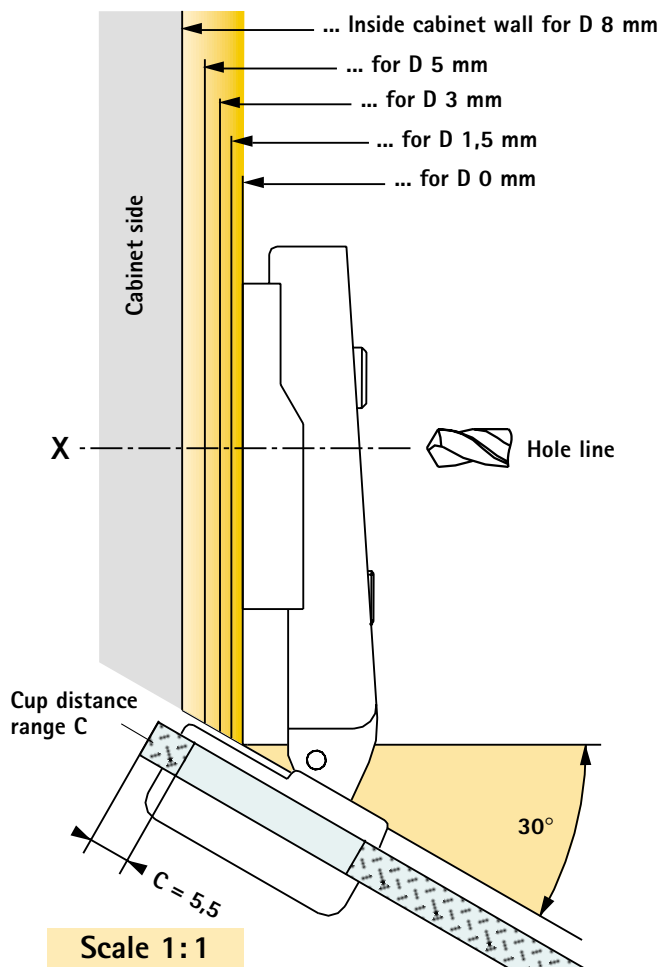

Scale 1:1

#### Inset

\* Reveal adjustment -0,5 mm / +3 mm

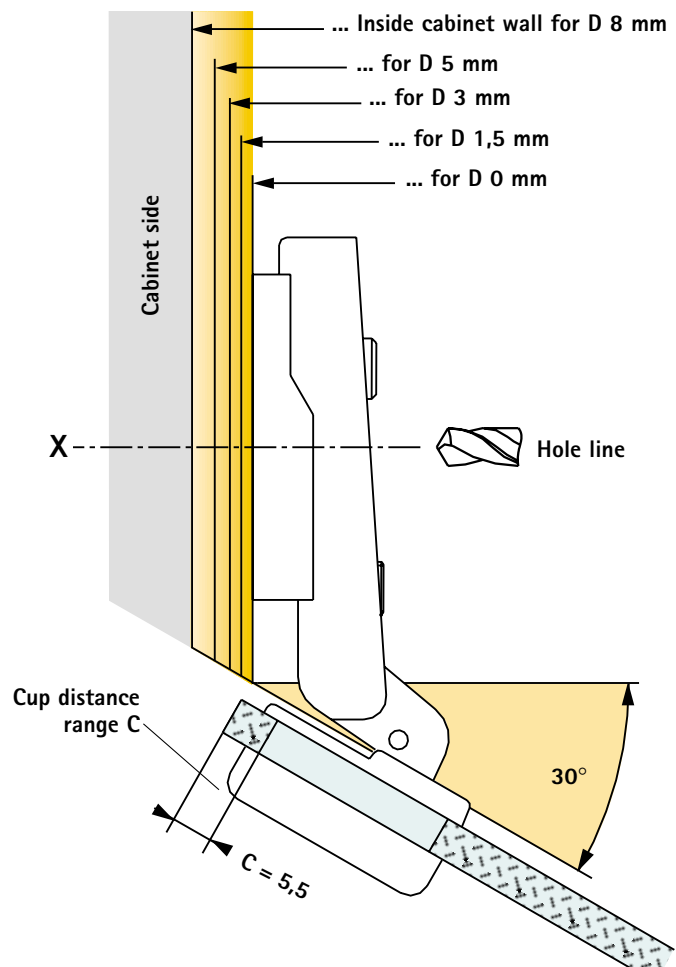

# Intermat 9924 W45

## Fast-assembly hinge for corner cabinets

### Cup diameter 26 mm

### Opening angle 95°

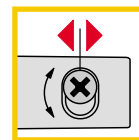
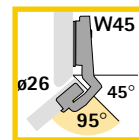

**Concealed hinge, snap-on assembly, integrated door overlay and eccentric depth adjustment.**

Opening angle 95°, cup diameter 26 mm.

For small doors and narrow frame doors for corner cabinets with 45° face angles.

Intermat 9924 W45 hinges are snapped onto the mounting plate.

Depth adjustment via eccentric screw -0,5 mm/+3,5 mm.

Height adjustment via mounting plate +2 mm/-2 mm, see pages 3.110 - 3.112.

Cup fixing screw ø 3,5 x 13 mm nickel-plated, for cup T42/26

Order no. 048 296, PU 200

#### Cup version

**Cup T42/26**  
Screw-on  
Nickel-plated steel



**Cup T43/26**  
Press-in  
Nickel-plated steel

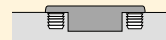

#### Hinge version

#### Mounting option

#### Article/order number

Cranking 6 mm

Full overlay

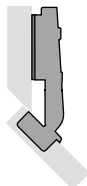

#### Intermat 9924 W45

- self-closing

Packaging unit 50 pcs

● 9924 W45-T42/26  
**079 310**

● 9924 W45-T43/26  
**079 312**

Cranking - 5 mm

Inset

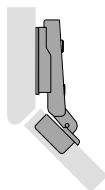

#### Intermat 9924 W45

- self-closing

Packaging unit 50 pcs

● 9924 W45-T42/26  
**079 311**

● 9924 W45-T43/26  
**079 313**

#### Mounting example Intermat 9924 W45 Full overlay

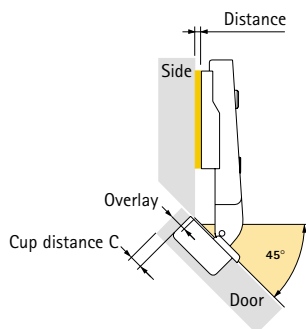

#### Mounting example Intermat 9924 W45 Inset

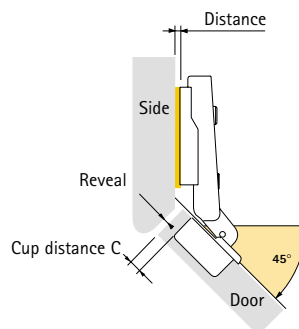

## Specification

Hettich Intermat 9924 W45  
 Snap-on assembly and eccentric depth adjustment  
 Cup diameter 26 mm for 45° corners  
 and doors for doors with narrow frames  
 Opening angle 95°

### Cover cap for Intermat hinges

Nickel-plated steel  
**Order no. 013 300**  
 Black plastic  
**Order no. 048 043**  
 PU = 50 pcs

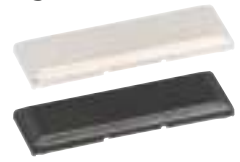

| Cup distance<br>C mm   | Door thickness mm |     |     |     |     |     |     |     |     |     |     |
|--|-------------------|-----|-----|-----|-----|-----|-----|-----|-----|-----|-----|
|  | 15                | 16  | 17  | 18  | 19  | 20  | 21  | 22  | 23  | 24  | 25  |
| <b>Minimum reveal per door – allow for in distance calculation</b> |                   |     |     |     |     |     |     |     |     |     |     |
| Table entries apply to doors with 0 mm radius                      |                   |     |     |     |     |     |     |     |     |     |     |
| 3  | 0,5               | 0,9 | 1,3 | 2,1 | 2,9 | 3,7 | 4,6 | 5,6 | 6,5 | 7,4 | 8,4 |
| 4  | 0,5               | 0,8 | 1,2 | 1,8 | 2,5 | 3,3 | 4,2 | 5,0 | 5,9 | 6,8 | 7,7 |
| 4,5  | 0,5               | 0,8 | 1,2 | 1,8 | 2,4 | 3,1 | 4,0 | 4,8 | 5,6 | 6,5 | 7,4 |
| 5  | 0,5               | 0,8 | 1,2 | 1,7 | 2,2 | 2,9 | 3,7 | 4,5 | 5,3 | 6,1 | 7,0 |
| 5,5  | 0,5               | 0,8 | 1,1 | 1,5 | 2,0 | 2,7 | 3,5 | 4,2 | 5,0 | 5,8 | 6,6 |

#### Note:

Drawings on this page are to full scale and show the hinges plus mounting plate distances. By drawing in the required cup distance C (3-5,5 mm), the door overlay can be measured directly from the applicable distance line.

The distance from the **cabinet front edge to X** on the selected distance line is also equal to the hole line distance from the cabinet front edge.

For **inset-mounted** doors, the cup distance and door thickness must be taken into account when determining the **minimum door reveal**.

The minimum reveal is reduced for doors with radii: 1 mm radius: table entry – 0,4 mm  
 3 mm radius: table entry – 1,2 mm

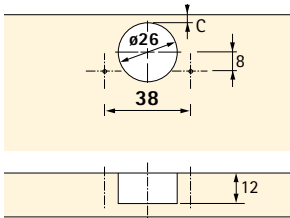

T42/26 hole dimensions

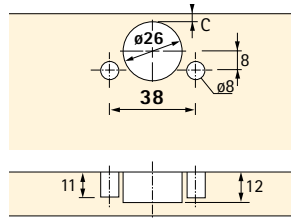

T43/26 hole dimensions

#### Full overlay

\* Overlay adjustment +0,5 mm / -3 mm

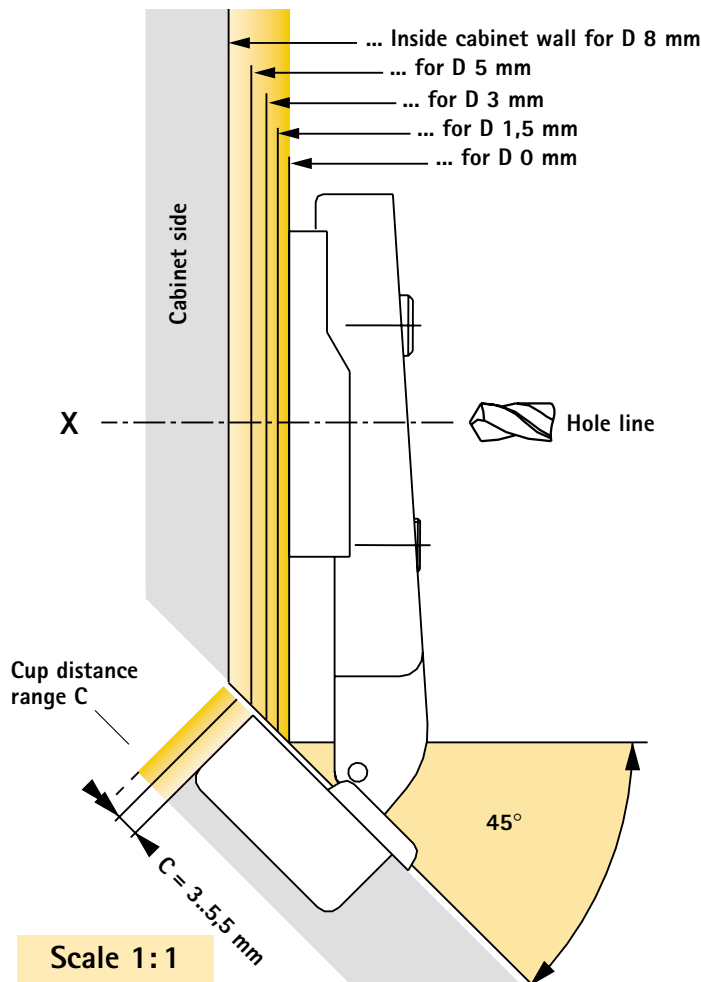

#### Inset

\* Reveal adjustment -0,5 mm / +3 mm

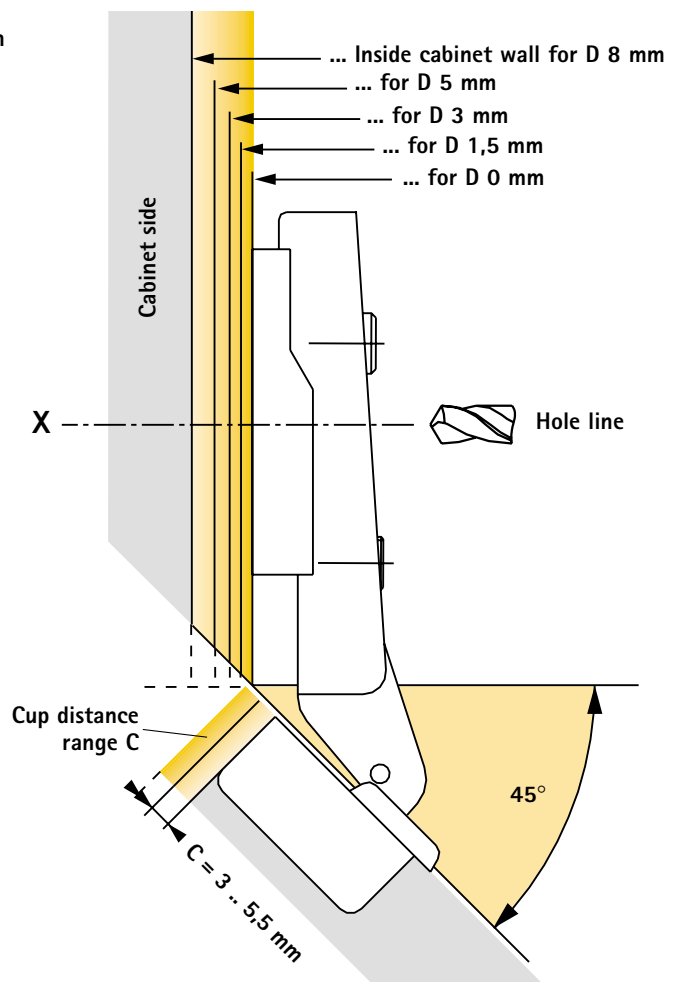

# Intermat 9904 W45

## Fast-assembly glass door hinge for corner cabinets

### Cup diameter 26 mm

### Opening angle 95°

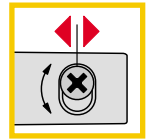
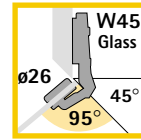

**Concealed glass door hinge, snap-on assembly, integrated door overlay and eccentric depth adjustment.**

Opening angle 95°, glass door hole diameter 26 mm.

For glass doors with 45° corners, panel thickness from 4 - 6,5 mm.

For a glass panel thickness from 5,5 mm, order 2 x cup fixing screws (order number 069 611, PU 1000).

Intermat 9904 W45 hinges are snapped onto the mounting plate.

For various decorative caps, see page 3.93.

Depth adjustment via eccentric screw -0,5 mm/+3,5 mm.

Height adjustment via mounting plate +2 mm/-2 mm, see pages 3.110 - 3.112.

#### Cup version

##### Cup T 1

Screw-on  
Black plastic



3

#### Hinge version

#### Mounting option

#### Article/order number

Cranking 6 mm

Full overlay

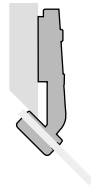

#### Intermat 9904 W45

- self-closing

Packaging unit 50 pcs

- 9904 W45-T1
- 079 316

Cranking - 5 mm

Inset

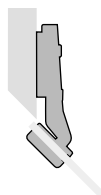

#### Intermat 9904 W45

- self-closing

Packaging unit 50 pcs

- 9904 W45-T1
- 079 317

#### Mounting example Intermat 9904 W45 Full overlay

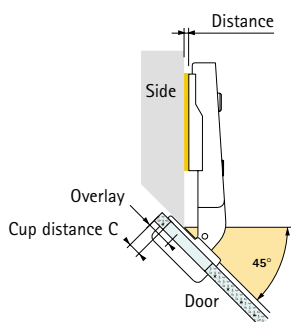

#### Mounting example Intermat 9904 W45 Inset

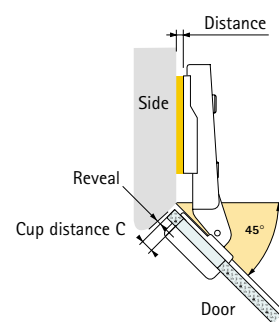

## Specification

Hettich Intermat 9904 W45

Snap-on assembly and eccentric depth adjustment for glass doors with 45° corners

Glass door hole diameter 26 mm, glass thickness 4 - 6,5 mm

Opening angle 95°

### Cover cap for Intermat hinges

Nickel-plated steel

Order no. **013 300**

Black plastic

Order no. **048 043**

PU = 50 pcs



| Finish            | Order no. | PU | Finish            | Order no. | PU |
|-------------------|-----------|----|-------------------|-----------|----|
| high-gloss gold   | 040 340   | 50 | high-gloss gold   | 040 494   | 50 |
| high-gloss chrome | 040 341   | 50 | high-gloss chrome | 040 495   | 50 |
| black             | 070 051   | 50 | black             | 070 052   | 50 |
| matt nickel       | 070 712   | 50 | matt nickel       | 070 713   | 50 |
| metallic brown    | 040 342   | 50 |                   |           |    |

#### Note:

Drawings on this page are to full scale and show the hinges plus mounting plate distances. By drawing in the required cup distance  $C = 5,5$  mm, the door overlay can be measured directly from the applicable distance line.

The distance from the **cabinet front edge to X** on the selected distance line is also equal to the hole line distance from the cabinet front edge.

For **inset-mounted** doors, the cup distance and door thickness must be taken into account when determining the **minimum door reveal**

Decorative cap A



Decorative cap B

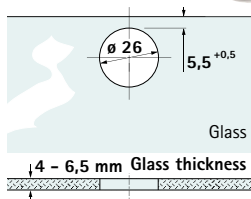

T1 hole dimensions

#### Full overlay

\* Overlay adjustment +0,5 mm / -3 mm

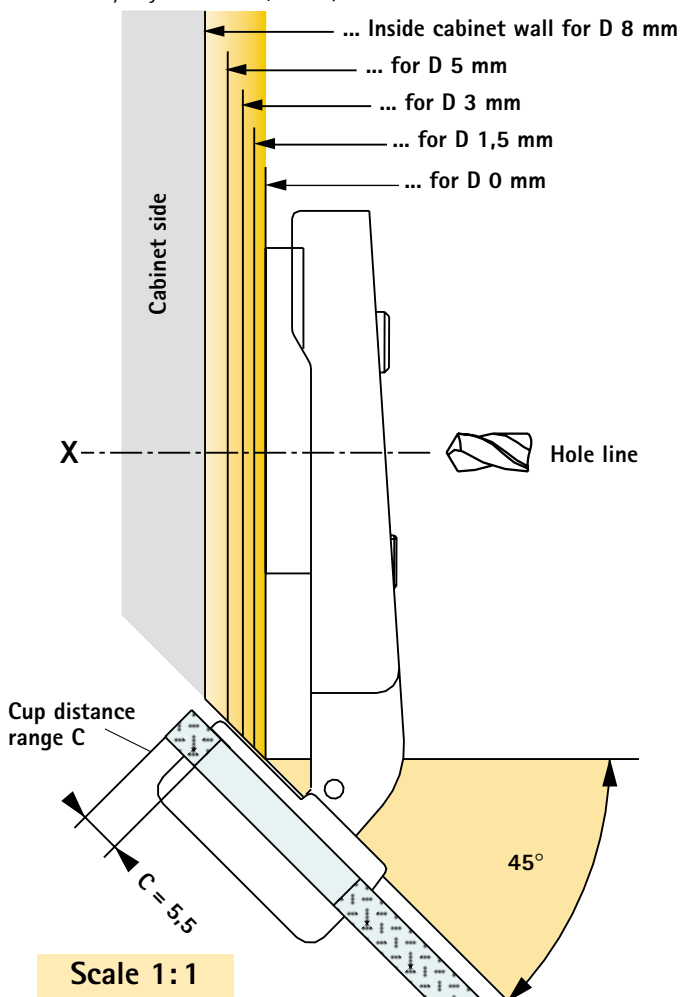

Scale 1:1

#### Inset

\* Reveal adjustment -0,5 mm / +3 mm

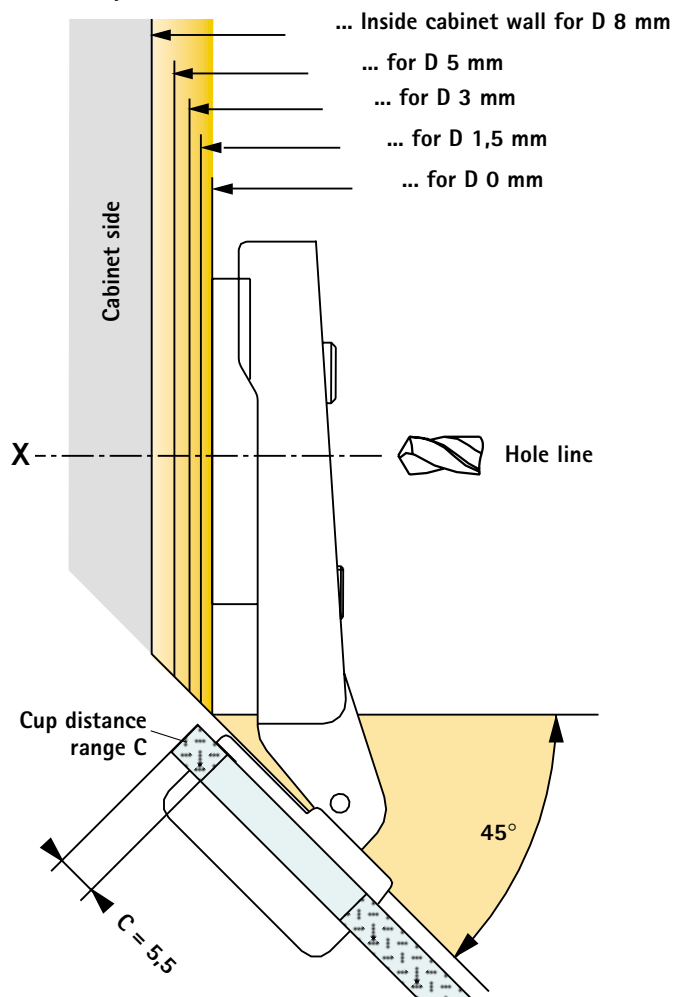

# Intermat 9936 Alu Fast-assembly hinge for aluminium frame doors Opening angle 95°

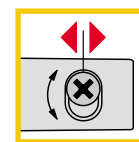
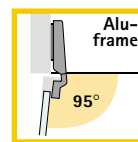

Concealed hinge, snap-on assembly,  
integrated door overlay and eccentric depth adjustment.

Opening angle 95°.

For doors with aluminium frames.

Interimat 9936 Alu hinges are snapped onto the mounting plate.

**DIN 7982 cup fixing screws are supplied.**

Depth adjustment via eccentric screw -0,5 mm/+3,5 mm.

Height adjustment via mounting plate +2 mm/-2 mm, see pages 3.110 - 3.112.

## Cup version

### Cup Alu T 1

Screw-on

Nickel-plated zinc diecast

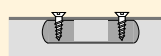

## Hinge version

Cranking 0 mm



## Mounting option

Full overlay

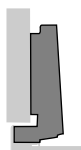

## Article/order number

### Interimat 9936 Alu

● self-closing

Packaging unit 10 pcs

● 9936-Alu  
T1

072 994

Door buffer Silent System

Packaging unit 50 pcs

— drill-in

048 047

Cranking 9,5 mm



Half overlay

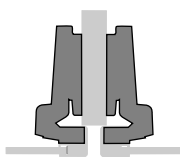

### Interimat 9936 Alu

● self-closing

Packaging unit 10 pcs

● 9936-Alu  
T1

077 728

Door buffer Silent System

Packaging unit 50 pcs

— drill-in

048 047

Cranking 16 mm



Inset

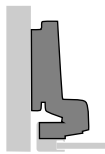

### Interimat 9936 Alu

● self-closing

Packaging unit 10 pcs

● 9936-Alu  
T1

077 729

Door buffer Silent System

Packaging unit 50 pcs

— screw-on

048 048

## Specification

Hettich Intermat 9936 Alu  
 Snap-on assembly  
 Eccentric depth adjustment  
 for aluminium door frames  
 Opening angle 95°

## Cover cap for Intermat hinges

Nickel-plated steel  
**Order no. 013 300**  
 Black plastic  
**Order no. 048 043**  
 PU = 50 pcs



### Assembly:

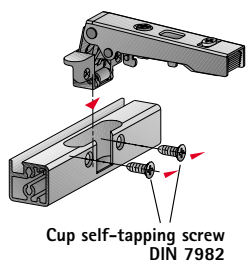

Cup self-tapping screw  
 DIN 7982

### Milling diagram

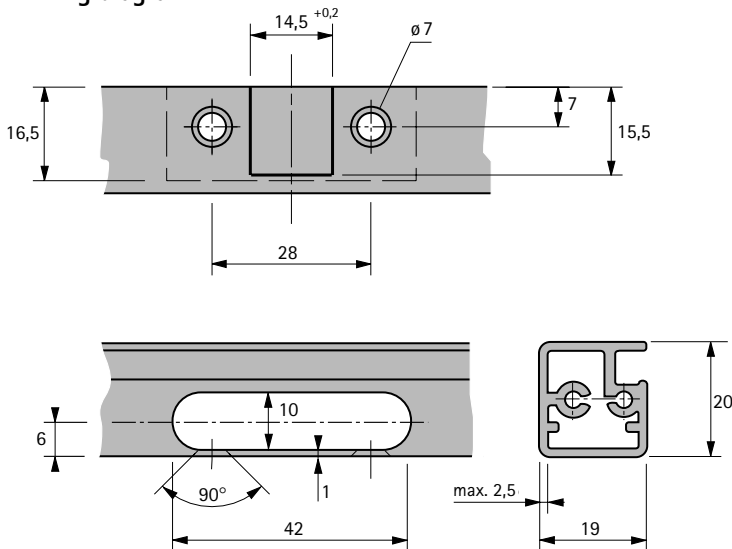

The minimum reveal for the recommended profile is 1 mm  
 (2 mm for half overlay version)

Door  
 protrusion T for  
 0 mm distance  
 and 3 mm cup  
 distance

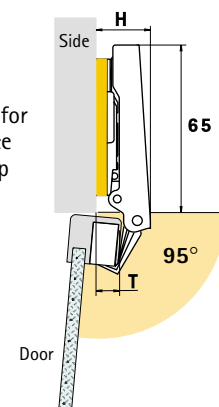

| Cranking<br>mm | H<br>mm | T<br>mm |
|----------------|---------|---------|
| 0              | 18,5    | 6,0     |
| 9,5            | 28,0    | 15,5    |
| 16             | 34,5    | 22,0    |

3

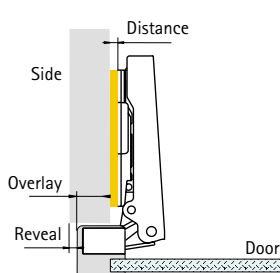

| Distance<br>D mm | Overlay mm |    |   |   |   |    |    |    |    |    |    |    |
|------------------|------------|----|---|---|---|----|----|----|----|----|----|----|
|                  | 5          | 6  | 7 | 8 | 9 | 10 | 11 | 12 | 13 | 14 | 15 | 16 |
|                  | 11         | 10 | 9 | 8 | 7 | 6  | 5  | 4  | 3  | 2  | 1  | 0  |

\* Overlay adjustment +2 mm, -4 mm

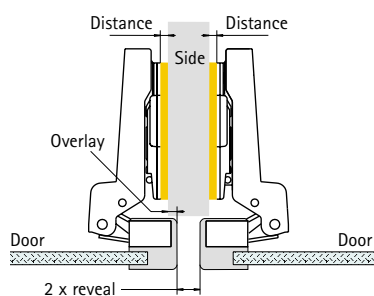

| Distance<br>D mm | Overlay mm |     |     |     |     |     |     |
|------------------|------------|-----|-----|-----|-----|-----|-----|
|                  | 0          | 1   | 2   | 3   | 4   | 5   | 6,5 |
|                  | 6,5        | 5,5 | 4,5 | 3,5 | 2,5 | 1,5 | 0   |

\* Overlay adjustment +2 mm, -4 mm

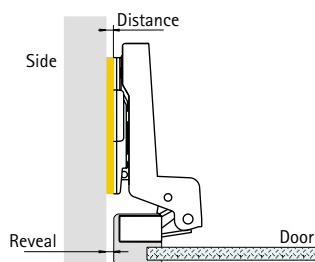

| Distance<br>D mm | Reveal mm |   |   |   |   |
|------------------|-----------|---|---|---|---|
|                  | 1,5       | 2 | 3 | 4 | 5 |
|                  | 1,5       | 2 | 3 | 4 | 5 |

\* Reveal adjustment -2 mm, +4 mm

# Sets

## Aluminium frame doors, 19 mm

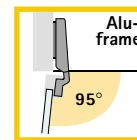

Aluminium frame doors provide an optically pleasing material mix for all furniture fronts.

This profile can be customised to size by the customer.

The aluminium frame doors are designed for use with the Intermat 9936 Alu-hinge. The required drilling/milling is provided.

Door frames can be adjusted to individual cabinet heights.

Vertical and cross profiles can be easily shortened.

### A complete aluminium frame contains:

- ① 1 vertical profile set
- + ② 1 cross profile set
- + ③ 1 angle set

#### ① Vertical profile set, contains:

- 1 Aluminium vertical profile with hinge milling, anodised silver
- 1 Aluminium vertical profile without milled hinge recess, silver anodised
- 2 x sealing strip



#### ② Cross profile set, contains:

- 2 Aluminium cross profiles, anodised silver
- 2 x sealing strip



| Order no. | Hinge milled recess |      |      |      | Profile F | Door heights | PU set      |
|-----------|---------------------|------|------|------|-----------|--------------|-------------|
|           | A mm                | B mm | C mm | D mm | mm        | mm           |             |
| 079 667   | 122                 | 96   | -    | -    | 122       | 340          | 260 - 340   |
| 079 668   | 122                 | 192  | -    | -    | 122       | 436          | 356 - 436   |
| 079 669   | 122                 | 288  | -    | -    | 122       | 532          | 452 - 532   |
| 079 670   | 122                 | 384  | -    | -    | 122       | 628          | 548 - 628   |
| 079 671   | 122                 | 480  | -    | -    | 122       | 724          | 644 - 724   |
| 079 672   | 122                 | 576  | -    | -    | 122       | 820          | 740 - 820   |
| 079 673   | 138                 | 640  | -    | -    | 138       | 916          | 804 - 916   |
| 079 674   | 138                 | 768  | -    | -    | 138       | 1044         | 932 - 1044  |
| 079 675   | 138                 | 448  | 448  | -    | 138       | 1172         | 1060 - 1172 |
| 079 676   | 138                 | 512  | 512  | -    | 138       | 1300         | 1188 - 1300 |
| 079 677   | 138                 | 576  | 576  | -    | 138       | 1428         | 1316 - 1428 |
| 079 678   | 138                 | 640  | 640  | -    | 138       | 1556         | 1444 - 1556 |
| 079 679   | 154                 | 704  | 704  | -    | 154       | 1716         | 1572 - 1716 |
| 079 680   | 154                 | 544  | 480  | 544  | 154       | 1876         | 1732 - 1876 |
| 079 681   | 170                 | 576  | 576  | 576  | 170       | 2068         | 1892 - 2068 |

| Order no. | Profile G mm | PU set |
|-----------|--------------|--------|
| 079 682   | 294          | 1      |
| 079 683   | 394          | 1      |
| 079 684   | 494          | 1      |
| 079 685   | 594          | 1      |

- #### ③ Angle set contains:
- 4 fixing angles
  - 8 fixing screws



| Article   | Order no. | PU/set |
|-----------|-----------|--------|
| Angle set | 079 686   | 1      |

**Note:** On doors over 1m in height, the glazing must be stuck to the aluminium profile using commercially available adhesive.



# Aluminium frame profile

## Width 19 mm

## for Intermat 9936 Alu

### Can be made up to custom dimensions or ready-made up

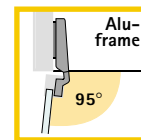

This profile can be customised to size by the customer.

- Silver anodised surface
- Usable with 4 mm glass thickness
- Safe installation with fixing angles and screws

Cross-section

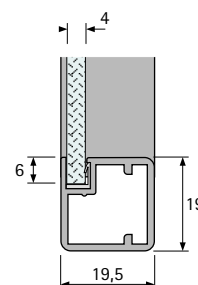

### Aluminium frame profile set, width 19 mm

contains:

- 2 aluminium frame profiles, silver anodised
- 2 sealing strips, plastic

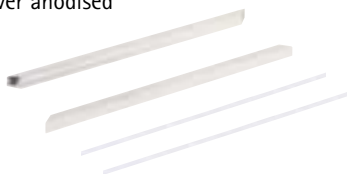

### Angle set

contains:

- 4 fixing angles
- 8 fixing screws

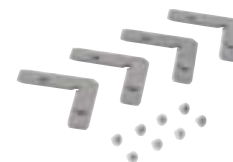

| Profile length mm | Order no. | PU    |
|-------------------|-----------|-------|
| 294               | 079 682   | 1 set |
| 394               | 079 683   | 1 set |
| 494               | 079 684   | 1 set |
| 594               | 079 685   | 1 set |
| 3000              | 013 639   | 1 set |

| Article   | Order no. | PU    |
|-----------|-----------|-------|
| Angle set | 079 686   | 1 set |

Attention: On doors over 1 m in height, the glazing must be stuck to the aluminium profile using commercially available adhesive.

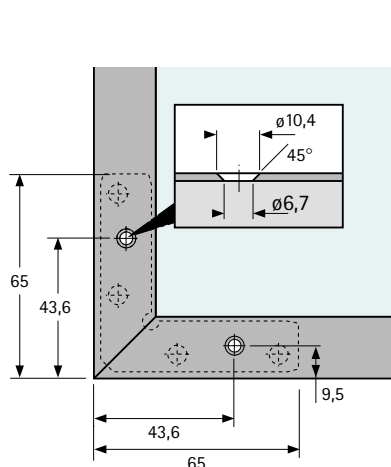

Glass cutting dimension = door width/height - 26 mm

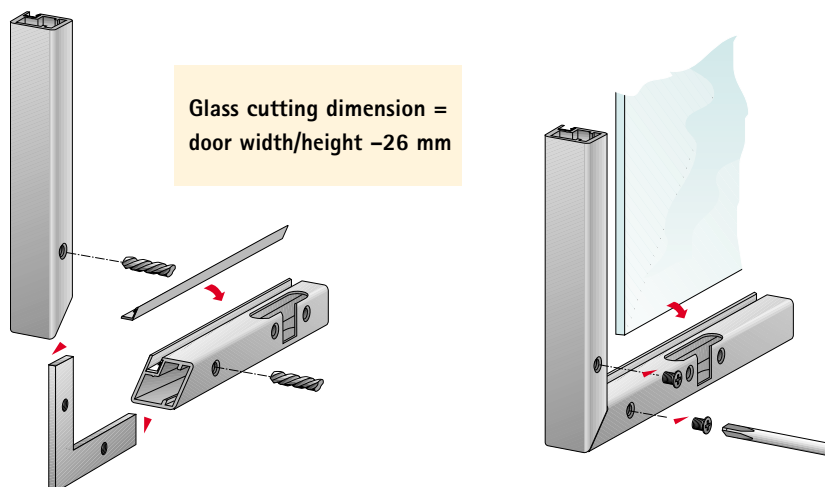

# Fax order to your specialist retailer

Simply fill in the fax form to receive a set of aluminium frame profiles fully customised to your dimensions, width 19 mm

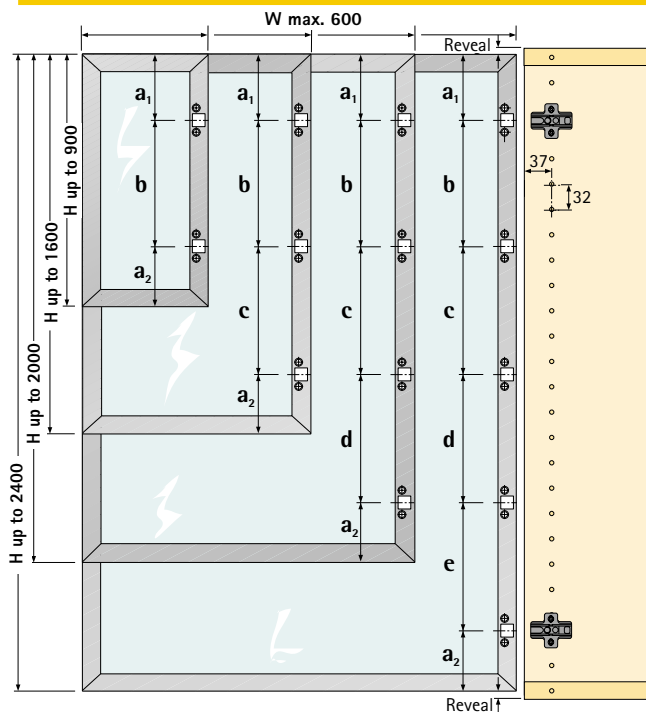

## Aluminium frame profile set, width 19 mm made to measure

contains: 4 aluminium frame profiles, silver anodised  
4 sealing profiles for 4 mm gauge glass

| Order no. | PU    | Door perimeter mm | Number of doors |
|-----------|-------|-------------------|-----------------|
| 041 281   | 1 set |                   |                 |

## Fabrication for an aluminium frame, width 19 mm

contains: mitre cuts, including cutting to length  
drill holes for mitre joint  
4 angle connectors  
8 countersunk screws

| Order no. | PU | Number of doors |
|-----------|----|-----------------|
| 041 314   | 1  |                 |

**Attention:** Use a separate order sheet for each frame size/door size.  
Please specify all measurements in mm!

|                                 | up to 900 | up to 1600 | up to 2000 | up to 2400 |
|---------------------------------|-----------|------------|------------|------------|
| <b>H</b>                        |           |            |            |            |
| <b>B</b><br>max. 600            |           |            |            |            |
| <b>a<sub>1</sub></b><br>min. 85 |           |            |            |            |
| <b>b</b>                        |           |            |            |            |
| <b>c</b>                        |           |            |            |            |
| <b>d</b>                        |           |            |            |            |
| <b>e</b>                        |           |            |            |            |
| <b>a<sub>2</sub></b><br>min. 85 |           |            |            |            |
| left<br>Number of doors         |           |            |            |            |
| right<br>Number of doors        |           |            |            |            |

## Fabrication for hinged doors

contains: 1 hinge slot

| Order no. | PU | Order quantity* |
|-----------|----|-----------------|
| 041 289   | 1  |                 |

\*Number of hinge slots

Intermat 9936 Alu,  
opening angle 95°,  
with cup fixing screw  
DIN 7982

| Version                       | Order no. | Stock    | Order quantity |
|-------------------------------|-----------|----------|----------------|
| Cranking 0 mm, full overlay   | 072 994   | Retailer |                |
| Cranking 9,5 mm, half overlay | 077 728   | Retailer |                |
| Cranking 16 mm, inset         | 077 729   | Retailer |                |

Mounting plates and cover caps for Intermat hinges must be ordered separately

|                         |                              |
|-------------------------|------------------------------|
| Joiner/interior fitter: | Date: _____ Signature: _____ |
|                         |                              |

# Intermat 9944 Alu Fast-assembly hinge for aluminium frame doors Opening angle 125°

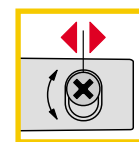
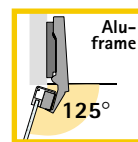

Concealed hinge, snap-on assembly,  
integrated door overlay and eccentric depth adjustment.

Opening angle 125°.

For doors with aluminium frames.

Intermat 9944 Alu hinges are snapped onto the mounting plate.

**DIN 7982 cup fixing screws are supplied.**

Depth adjustment via eccentric screw -0,5 mm/+3,5 mm.

Height adjustment via mounting plate +2 mm/-2 mm, see pages 3.110 - 3.112.

## Cup version

### Cup Alu T 1

Screw-on

Nickel-plated die-cast zinc

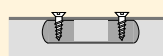

## Hinge version

Cranking 0 mm



## Mounting option

Full overlay

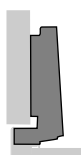

## Article/order number

### Intermat 9944 Alu

● self-closing

Packaging unit 10 pcs

● 9944-Alu  
T1

020 169

Door buffer Silent System

Packaging unit 50 pcs

— drill-in

048 047

Cranking 9,5 mm



Half overlay

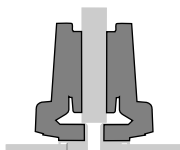

### Intermat 9944 Alu

● self-closing

Packaging unit 10 pcs

● 9944-Alu  
T1

020 170

Door buffer Silent System

Packaging unit 50 pcs

— drill-in

048 047

## Assembly:

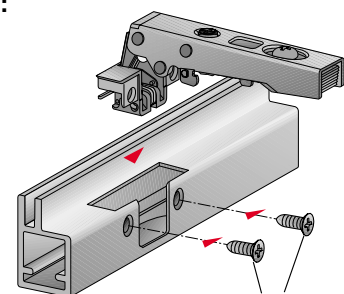

Cup fixing screw  
DIN 7982

## Specification

Hettich Intermat 9944 Alu  
 Snap-on assembly  
 Eccentric depth adjustment  
 for aluminium door frames  
 Opening angle 125°

## Cover cap for Intermat hinges

Nickel-plated steel  
**Order no. 013 300**  
 Black plastic  
**Order no. 048 043**  
 PU = 50 pcs



## Milling diagram

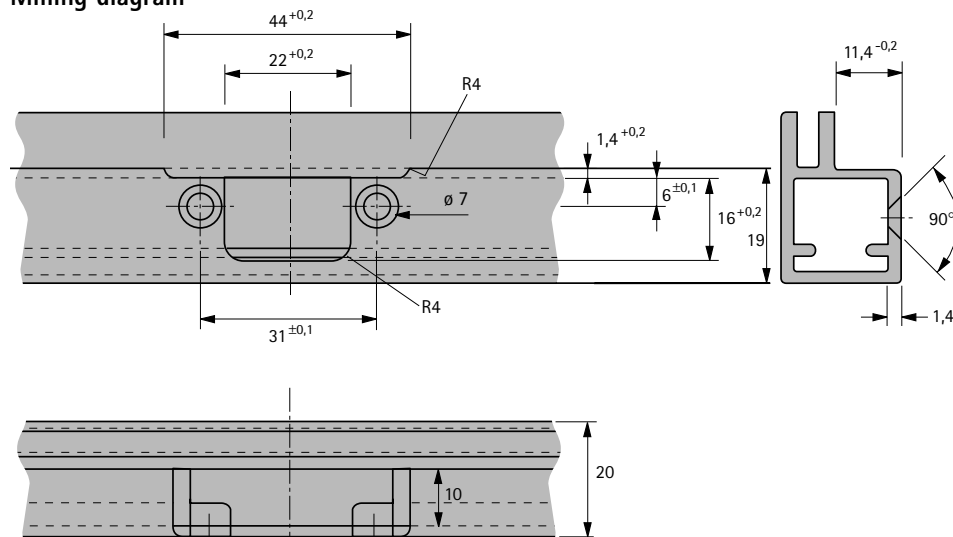

The minimum reveal for the recommended profile is 1 mm  
 (2 mm for half overlay version)

Door  
 protrusion T for  
 0 mm distance  
 and 3 mm cup  
 distance

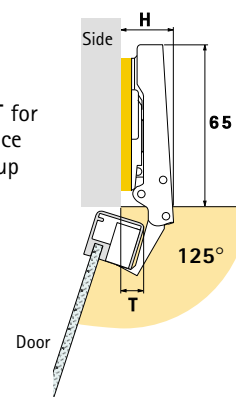

| Cranking<br>mm | H<br>mm | T<br>mm |
|----------------|---------|---------|
| 0              | 18,5    | 8,0     |
| 9,5            | 28,0    | 17,5    |

3

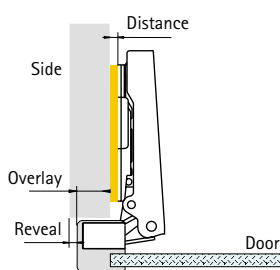

| Distance<br>D mm | Overlay mm |     |     |     |      |      |      |      |      |      |      |      |
|------------------|------------|-----|-----|-----|------|------|------|------|------|------|------|------|
|                  | 6,5        | 7,5 | 8,5 | 9,5 | 10,5 | 11,5 | 12,5 | 13,5 | 14,5 | 15,5 | 16,5 | 17,5 |
|                  | 11         | 10  | 9   | 8   | 7    | 6    | 5    | 4    | 3    | 2    | 1    | 0    |

\* Overlay adjustment +0,5 mm, -4 mm

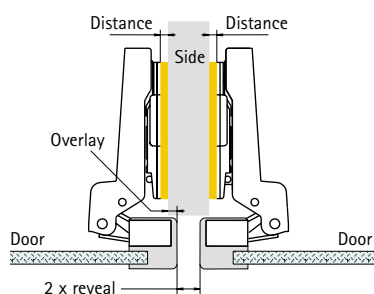

| Distance<br>D mm | Overlay mm |   |     |     |     |     |     |     |   |
|------------------|------------|---|-----|-----|-----|-----|-----|-----|---|
|                  | -3         | 0 | 1,5 | 2,5 | 3,5 | 4,5 | 5,5 | 6,5 | 8 |
|                  | 11         | 8 | 6,5 | 5,5 | 4,5 | 3,5 | 2,5 | 1,5 | 0 |

\* Overlay adjustment +0,5 mm, -4 mm

# Intermat 9930

## Fast-assembly hinge for corner cabinet folding doors

### Opening angle 50°/90°

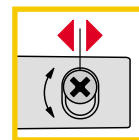
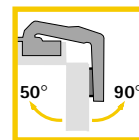

**Concealed hinge, snap-on assembly, integrated door overlay and eccentric depth adjustment.**

Opening angle 50°/90°, cup diameter 35 mm.

For corner cabinets with folding doors.

Standard Hettich cup holes are used for the door elements. Cutaway or special holes are not required.

Intermat 9930 hinges are snapped onto the mounting plate.

Depth adjustment via eccentric screw -0,5 mm/+3,5 mm.

Height adjustment via mounting plate +2 mm/-2 mm, see pages 3.110 - 3.112.

Cup fixing screw  $\varnothing$  3,5 x 13 mm nickel-plated, for cup T 42

Order no. 048 296, PU 200

#### Cup version

##### Cup T 42

Screw-on  
Nickel-plated  
steel

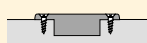

##### Cup T 43

Press-in  
Nickel-plated  
steel

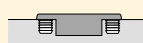

##### Cup TB 43

Press-in  
Nickel-plated  
steel

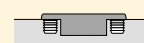

##### Cup Flash

Fast-assembly  
Nickel-plated  
steel



#### Hinge version



#### Mounting option

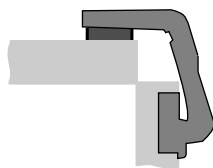

#### Article/order number

##### Intermat 9930

- self-closing

● 9930-T42

045 036

● 9930-T43

045 037

● 9930-TB43

045 038

● 9930-Flash

045 039

Packaging unit 50 pcs

## Specification

Hettich Intermat 9930  
 Snap-on assembly  
 Eccentric depth adjustment  
 Folding door hinge for corner cabinets  
 Opening angle 50°/90°

## Cover cap for Intermat hinges

Nickel-plated steel  
**Order no. 013 300**  
 Black plastic  
**Order no. 048 043**  
 PU = 50 pcs

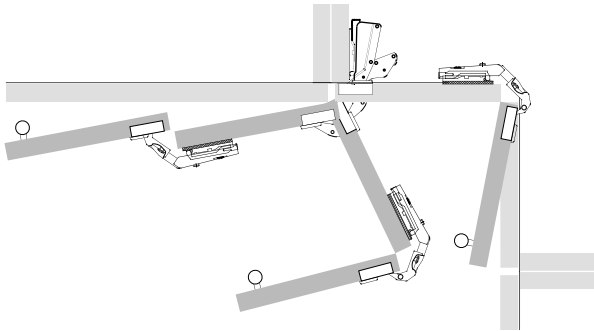
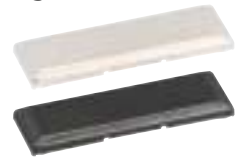

At the start of its swing, the door element opens about 50° on the handle side.

This ensures that the whole corner cabinet door moves clear of any adjacent doors or drawer fronts.

In the open position, the two door elements form a straight line. The cabinet interior is fully accessible for user convenience.

The self-closing feature eliminates the need for a catch on the handle side.

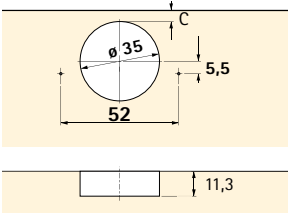

T42 hole dimensions

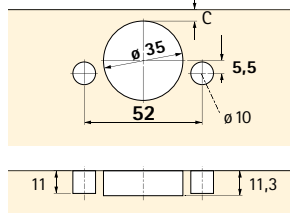

T43 / Flash hole dimensions

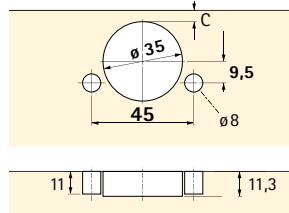

TB43 hole dimensions

### Features:

- Identical door elements
- No cutaway required in cup holes
- Simple adaptation to door thickness by diagonal adjustment
- Hole line distance in attached door 41 mm

### Features:

- All cup holes in one door
- Hairline reveal possible between door elements
- No cutaway required in cup holes
- Identical door width for both elements
- Simple adaptation to door thickness by diagonal adjustment
- Identical cup distance on both sides of attached door
- Hole line distance in free door 37 mm

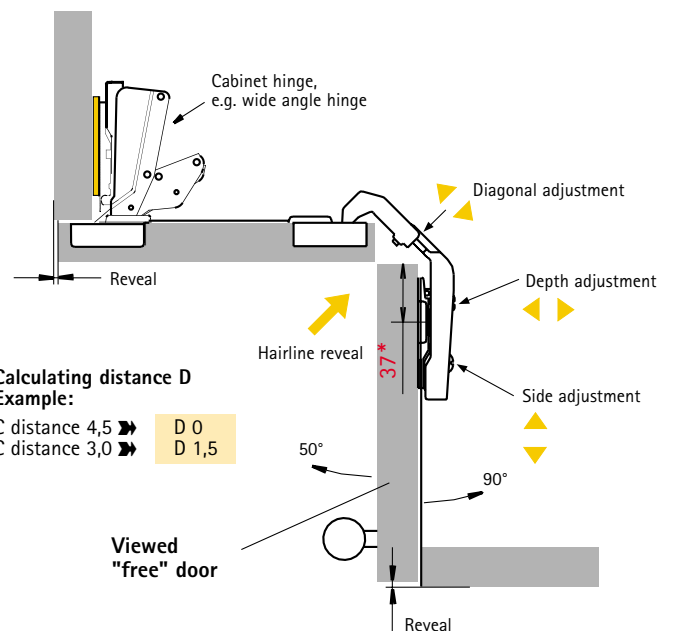
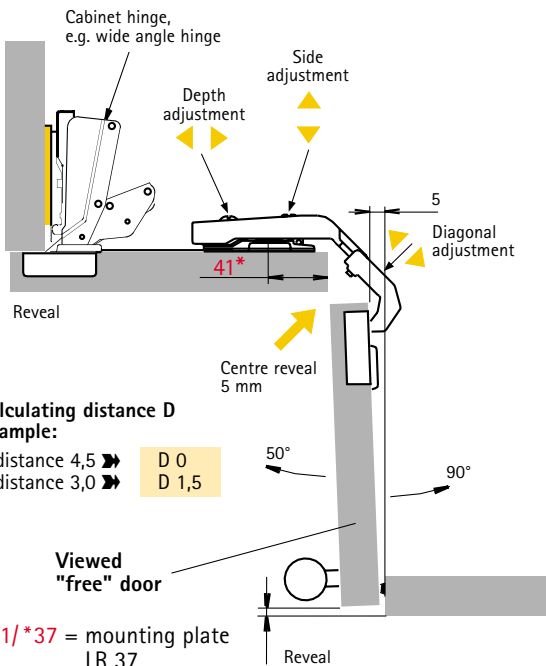

The **diagonal adjustment** can be used to adjust the hinges for **different door thicknesses** from 16 - 21 mm and **different cup distances** from 3 - 6 mm.

# Intermat 9930 FIX

## Toolless fast-assembly for corner cabinet folding doors

### Opening angle 50°/90°

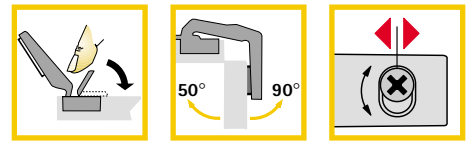

**Concealed hinge, snap-on assembly plus toolless cup assembly, integrated door overlay and eccentric depth adjustment.**

Opening angle 50°/90°, cup diameter 35 mm.

For corner cabinets with folding doors.

Standard Hettich cup holes are used for the door elements.

Cutaway or special holes are not required.

Intermat 9930 FIX hinges are snapped onto the mounting plate and also feature toolless cup assembly.

Depth adjustment via eccentric screw -0,5 mm/+3,5 mm.

Height adjustment via mounting plate +2 mm/-2 mm, see pages 3.110 - 3.112.

#### Cup version

##### Cup T FIX

Toolless  
Nickel-plated steel

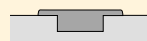

##### Cup TH FIX

Toolless  
with pegs  
Nickel-plated steel

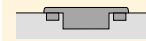

##### Cup TB FIX

Toolless  
with pegs  
Nickel-plated steel

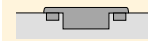

#### Hinge version



#### Mounting option

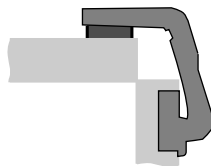

#### Article/order number

##### Intermat 9930 FIX

- self-closing

● 9930-  
T FIX

045 041

● 9930-  
TH FIX

045 042

Packaging unit 50 pcs

● 9930-  
TB FIX

045 043

## Specification

Hettich Intermat 9930 FIX

Snap-on assembly

Eccentric depth adjustment plus toolless cup assembly

Folding door hinge for corner cabinets

Opening angle 50°/90°

## Cover cap for Intermat hinges

Nickel-plated steel

Order no. **013 300**

Black plastic

Order no. **048 043**

PU = 50 pcs

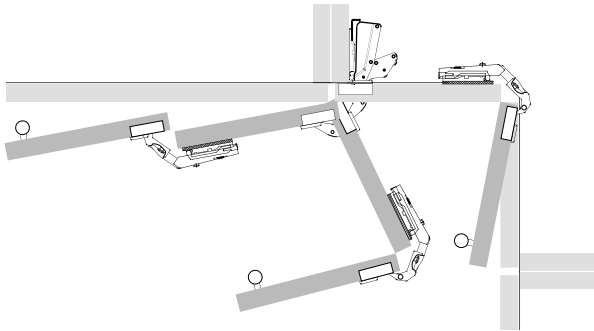
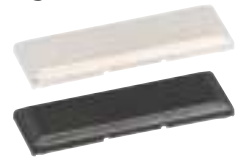

At the start of its swing, the door element opens about 50° on the handle side.

This ensures that the whole corner cabinet door moves clear of any adjacent doors or drawer fronts.

In the open position, the two door elements form a straight line. The cabinet interior is fully accessible for user convenience.

The self-closing feature eliminates the need for a catch on the handle side.

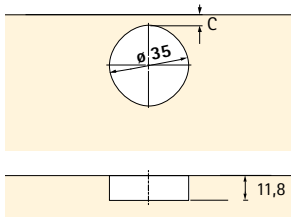

T FIX hole dimensions

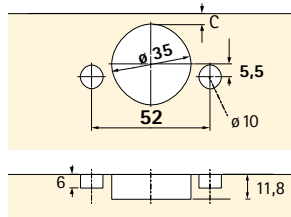

TH FIX hole dimensions

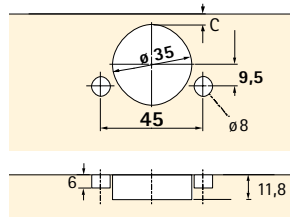

TB FIX hole dimensions

### Features:

- Identical door elements
- No cutaway required in cup holes
- Simple adaptation to door thickness by diagonal adjustment
- Hole line distance in attached door 41 mm

### Features:

- All cup holes in one door
- Hairline reveal possible between door elements
- No cutaway required in cup holes
- Identical door width for both elements
- Simple adaptation to door thickness by diagonal adjustment
- Identical cup distance on both sides of attached door
- Hole line distance in free door 37 mm

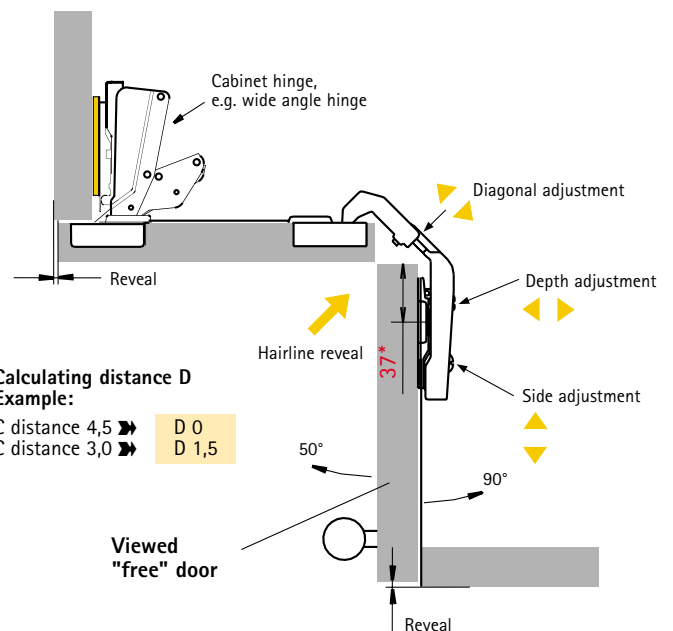
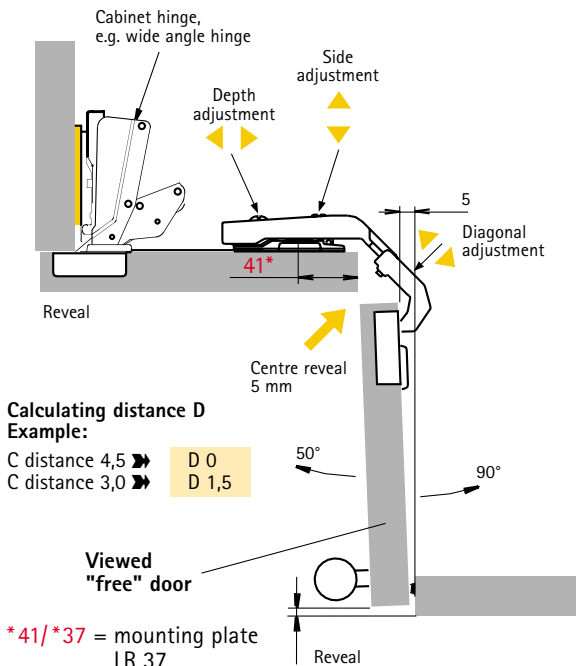

The **diagonal adjustment** can be used to adjust the hinges for **different door thicknesses** from 16 - 21 mm and **different cup distances** from 3 - 6 mm.

# Intermat 9945

## Fast-assembly hinge

### 12 mm overlay adjustment

### Opening angle 95°

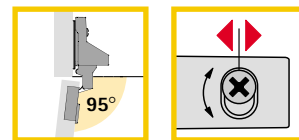

**Concealed hinge, snap-on assembly, 12 mm door overlay adjustment, integrated height and eccentric depth adjustment.**

Opening angle 95°, cup diameter 35 mm.

For overlay and inset doors. The variable overlay adjustment operates in parallel and ensures highest accuracy. The factory **overlay** setting is **14,5 mm**. Interimat 9945 hinges are snapped onto the mounting plate.

Depth adjustment via eccentric screw -0,5 mm/+3,5 mm.

Height adjustment via mounting plate +2 mm/-2 mm, see pages 3.110 - 3.112.

Cup fixing screw  $\varnothing$  3,5 x 13 mm nickel-plated, for cup T 42

Order no. 048 296, PU 200

#### Cup version

**Cup T 42**  
Screw-on  
Nickel-plated steel



**Cup T 43**  
Press-in  
Nickel-plated steel



**Cup Flash**  
Fast-assembly  
Nickel-plated steel



#### Hinge version

Factory setting: 14,5 mm overlay



#### Mounting option

Full overlay

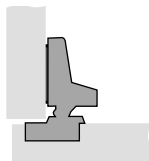

#### Article/order number

##### Interimat 9945

- self-closing

Packaging unit 50 pcs

● **9945-T 42**  
**074 684**

● **9945-T 43**  
**074 685**

● **9945-Flash**  
**074 686**

Half overlay

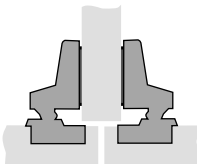

Inset

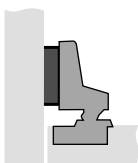

# Specification

Hettich Intermat 9945

Snap-on assembly

Eccentric depth adjustment

with variable 12 mm overlay adjustment

Opening angle 95°

| Cup distance<br>C mm   | Door thickness mm |     |     |     |     |     |     |     |     |     |     |     |     |     |
|--|-------------------|-----|-----|-----|-----|-----|-----|-----|-----|-----|-----|-----|-----|-----|
|  | 16                | 17  | 18  | 19  | 20  | 21  | 22  | 23  | 24  | 25  | 26  | 27  | 28  | 29  |
| <b>Minimum reveal per door – allow for in distance calculation</b> |                   |     |     |     |     |     |     |     |     |     |     |     |     |     |
| Table entries apply to doors with 0 mm radius                      |                   |     |     |     |     |     |     |     |     |     |     |     |     |     |
| 3  | 0,4               | 0,6 | 0,8 | 1,0 | 1,2 | 1,5 | 1,8 | 2,1 | 2,5 | 2,9 | 3,4 | 4,0 | 4,9 | 5,7 |
| 4  | 0,4               | 0,6 | 0,8 | 1,0 | 1,2 | 1,5 | 1,8 | 2,1 | 2,5 | 2,8 | 3,3 | 3,8 | 4,5 | 5,3 |
| 4,5  | 0,4               | 0,6 | 0,8 | 1,0 | 1,2 | 1,5 | 1,8 | 2,1 | 2,5 | 2,8 | 3,3 | 3,7 | 4,3 | 5,1 |
| 5  | 0,4               | 0,6 | 0,8 | 1,0 | 1,2 | 1,4 | 1,7 | 2,0 | 2,4 | 2,7 | 3,2 | 3,6 | 4,2 | 4,9 |
| 6  | 0,4               | 0,6 | 0,8 | 1,0 | 1,2 | 1,4 | 1,7 | 2,0 | 2,3 | 2,6 | 3,1 | 3,5 | 4,0 | 4,6 |
| 7  | 0,4               | 0,5 | 0,7 | 0,9 | 1,1 | 1,3 | 1,6 | 1,9 | 2,2 | 2,6 | 3,0 | 3,4 | 3,9 | 4,4 |
| 8  | 0,4               | 0,5 | 0,7 | 0,9 | 1,1 | 1,3 | 1,6 | 1,8 | 2,1 | 2,5 | 2,9 | 3,3 | 3,7 | 4,2 |

The minimum reveal is reduced for doors with radii: 1 mm radius: table entry – 0,4 mm  
3 mm radius: table entry – 1,2 mm

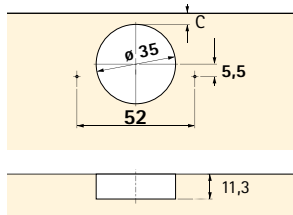

T42 hole dimensions

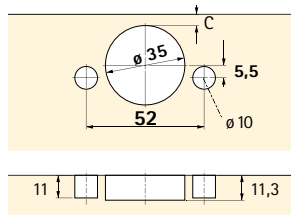

T43 / Flash hole dimensions

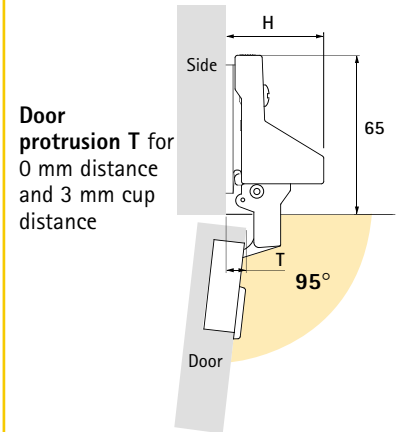

| H mm | T mm |
|------|------|
| 39,5 | 8,5  |

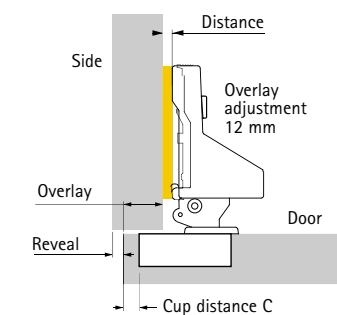

| C dist. | Overlay    | 10   | 11   | 12   | 13  | 14  | 15  | 16  | 17  | 18  | 19  | 20  | 21  | 22  |
|---------|------------|------|------|------|-----|-----|-----|-----|-----|-----|-----|-----|-----|-----|
| 3       | Distance   | 0    | 0    | 0    | 0   | 0   | 0   | 0   | 0   |     |     |     |     |     |
|         | Adjustment | 7,5  | 6,5  | 5,5  | 4,5 | 3,5 | 2,5 | 1,5 | 0,5 |     |     |     |     |     |
| 4       | Distance   | 0    | 0    | 0    | 0   | 0   | 0   | 0   | 0   | 0   |     |     |     |     |
|         | Adjustment | 8,5  | 7,5  | 6,5  | 5,5 | 4,5 | 3,5 | 2,5 | 1,5 | 0,5 |     |     |     |     |
| 5       | Distance   | 0    | 0    | 0    | 0   | 0   | 0   | 0   | 0   | 0   | 0   |     |     |     |
|         | Adjustment | 9,5  | 8,5  | 7,5  | 6,5 | 5,5 | 4,5 | 3,5 | 2,5 | 1,5 | 0,5 |     |     |     |
| 6       | Distance   | 0    | 0    | 0    | 0   | 0   | 0   | 0   | 0   | 0   | 0   | 0   |     |     |
|         | Adjustment | 10,5 | 9,5  | 8,5  | 7,5 | 6,5 | 5,5 | 4,5 | 3,5 | 2,5 | 1,5 | 0,5 |     |     |
| 7       | Distance   | 0    | 0    | 0    | 0   | 0   | 0   | 0   | 0   | 0   | 0   | 0   | 0   |     |
|         | Adjustment | 11,5 | 10,5 | 9,5  | 8,5 | 7,5 | 6,5 | 5,5 | 4,5 | 3,5 | 2,5 | 1,5 | 0,5 |     |
| 8       | Distance   | 0    | 0    | 0    | 0   | 0   | 0   | 0   | 0   | 0   | 0   | 0   | 0   | 0   |
|         | Adjustment | 12,5 | 11,5 | 10,5 | 9,5 | 8,5 | 7,5 | 6,5 | 5,5 | 4,5 | 3,5 | 2,5 | 1,5 | 0,5 |

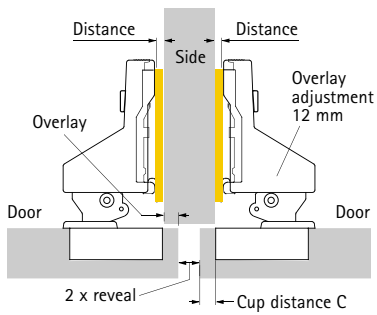

| C dist. | Overlay    | 0    | 1    | 2    | 3    | 4    | 5    | 6    | 7    | 8    | 9    |
|---------|------------|------|------|------|------|------|------|------|------|------|------|
| 3       | Distance   | 8,0  | 5,0  | 5,0  | 3,0  | 1,5  | 0    | 0    | 0    | 0    | 0    |
|         | Adjustment | 9,5  | 11,5 | 10,5 | 11,5 | 12,0 | 12,5 | 11,5 | 10,5 | 9,5  | 8,5  |
| 4       | Distance   | 8,0  | 8,0  | 5,0  | 5,0  | 3,0  | 1,5  | 0    | 0    | 0    | 0    |
|         | Adjustment | 10,5 | 9,5  | 11,5 | 10,5 | 11,5 | 12,0 | 12,5 | 11,5 | 10,5 | 9,5  |
| 5       | Distance   | 8,0  | 8,0  | 8,0  | 5,0  | 5,0  | 3,0  | 1,5  | 0    | 0    | 0    |
|         | Adjustment | 11,5 | 10,5 | 9,5  | 11,5 | 10,5 | 11,5 | 12,0 | 12,5 | 11,5 | 10,5 |
| 6       | Distance   | 8,0  | 8,0  | 8,0  | 8,0  | 5,0  | 5,0  | 3,0  | 1,5  | 1,5  | 0    |
|         | Adjustment | 12,5 | 11,5 | 10,5 | 9,5  | 11,5 | 10,5 | 11,5 | 12,0 | 11,0 | 11,5 |
| 7       | Distance   | 11,0 | 8,0  | 8,0  | 8,0  | 8,0  | 5,0  | 5,0  | 3,0  | 1,5  | 1,5  |
|         | Adjustment | 10,5 | 12,5 | 11,5 | 10,5 | 9,5  | 11,5 | 10,5 | 11,5 | 12,0 | 11,0 |
| 8       | Distance   | 11,0 | 11,0 | 8,0  | 8,0  | 8,0  | 8,0  | 5,0  | 5,0  | 3,0  | 1,5  |
|         | Adjustment | 11,5 | 10,5 | 12,5 | 11,5 | 10,5 | 9,5  | 11,5 | 10,5 | 11,5 | 12,0 |

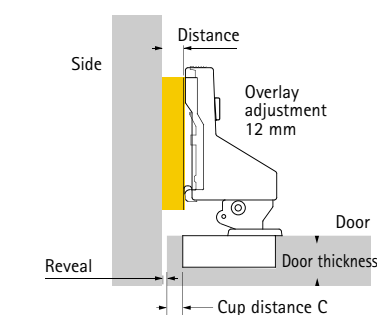

| C dist. | Door thickness | 16   | 17   | 18   | 19   | 20   | 21   | 22   | 23   | 24   | 25   | 26   | 27   | 28   | 29   |
|---------|----------------|------|------|------|------|------|------|------|------|------|------|------|------|------|------|
| 3       | Distance       | 8,0  | 8,0  | 8,0  | 8,0  | 8,0  | 8,0  | 8,0  | 8,0  | 8,0  | 8,0  | 8,0  | 11,0 | 11,0 | 11,0 |
|         | Adjustment     | 9,9  | 10,1 | 10,3 | 10,5 | 10,7 | 11,0 | 11,3 | 11,6 | 12,0 | 12,4 | 12,9 | 10,5 | 11,4 | 12,2 |
| 4       | Distance       | 8,0  | 8,0  | 8,0  | 8,0  | 8,0  | 8,0  | 8,0  | 8,0  | 11,0 | 11,0 | 11,0 | 11,0 | 11,0 | 11,0 |
|         | Adjustment     | 10,9 | 11,1 | 11,3 | 11,5 | 11,7 | 12,0 | 12,3 | 12,6 | 10,0 | 10,3 | 10,8 | 11,3 | 12,0 | 12,8 |
| 5       | Distance       | 8,0  | 8,0  | 8,0  | 8,0  | 8,0  | 8,0  | 11,0 | 11,0 | 11,0 | 11,0 | 11,0 | 11,0 | 11,0 | 11,0 |
|         | Adjustment     | 11,9 | 12,1 | 12,3 | 12,5 | 12,7 | 12,9 | 10,2 | 10,5 | 10,9 | 11,2 | 11,7 | 12,1 | 12,7 |      |
| 6       | Distance       | 11,0 | 11,0 | 11,0 | 11,0 | 11,0 | 11,0 | 11,0 | 11,0 | 11,0 | 11,0 | 11,0 | 11,0 | 11,0 | 11,0 |
|         | Adjustment     | 9,9  | 10,1 | 10,3 | 10,5 | 10,7 | 10,9 | 11,2 | 11,5 | 11,8 | 12,1 | 12,6 |      |      |      |
| 7       | Distance       | 11,0 | 11,0 | 11,0 | 11,0 | 11,0 | 11,0 | 11,0 | 11,0 | 11,0 | 11,0 | 11,0 | 11,0 | 11,0 | 11,0 |
|         | Adjustment     | 10,9 | 11,0 | 11,2 | 11,4 | 11,6 | 11,8 | 12,1 | 12,4 |      |      |      |      |      |      |
| 8       | Distance       | 11,0 | 11,0 | 11,0 | 11,0 | 11,0 | 11,0 | 11,0 | 11,0 | 11,0 | 11,0 | 11,0 | 11,0 | 11,0 | 11,0 |
|         | Adjustment     | 11,9 | 12,0 | 12,2 | 12,4 | 12,6 | 12,8 |      |      |      |      |      |      |      |      |

Technical information – see pages 3.16 – 3.19



# Intermat Konsul 5 Single pivot hinge With snap-on assembly for rebated doors

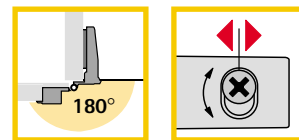

Single pivot hinge with visible knuckle. With or without decorative finials. With integrated protection, door overlay and eccentric depth adjustment.

Opening angle 180°, cup diameter 35 mm.

For rebated doors

For cabinet assembly with 19 mm panel thickness, the knuckle lies in the middle of the side panel.

Intermat Konsul 5 hinges are snapped onto the mounting plate.

Depth adjustment via eccentric screw -0,5 mm/+3,5 mm.

Height adjustment via mounting plate +2 mm/-2 mm, see pages 3.109.

## Cup version

### Cup T22

Screw-on

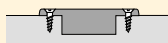

3

## Hinge version



## Mounting option

Full overlay

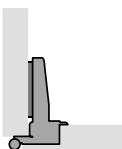

## Article / finish / order number

### Intermat Konsul 5 with decorative finials

● self-closing

Packaging unit 50 pcs

● Intermat Konsul 5-T22  
brass-plated

079 417

● Intermat Konsul 5-T22  
brown-coloured  
Knuckle brushed (antique)

079 418



Full overlay

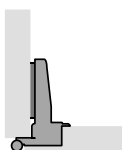

### Intermat Konsul 5 without decorative finials

● self-closing

Packaging unit 50 pcs

● Intermat Konsul 5-T22  
nickel-plated

079 419

● Intermat Konsul 5-T22  
bronze-plated

079 420

● Intermat Konsul 5-T22  
brass-plated

079 421

## Specification

Hettich Intermat Konsul 5  
 Single pivot hinge with visible knuckle  
 Eccentric depth adjustment for rebated doors  
 Opening angle 180°  
 Snap-on assembly with integrated security

## Cover cap for Intermat hinges

Nickel-plated steel  
 Order no. **013 300**

Brass-plated steel  
 Order no. **048 365**

Bronze-plated steel  
 Order no. **048 366**

PU = 50 pcs

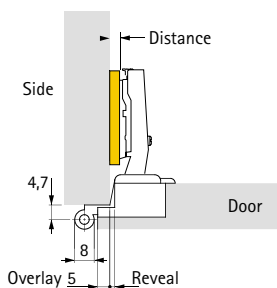

Door overlay 5 mm  
 for a mounting plate  
 with 0 mm distance

\* Overlay adjustment - 2 mm

No door  
 protrusion, free  
 interior space  
 for extension  
 elements

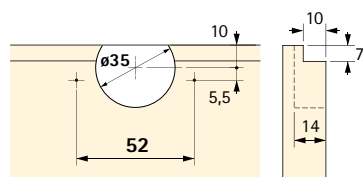
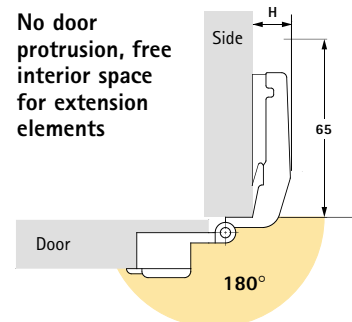

T22 hole dimensions

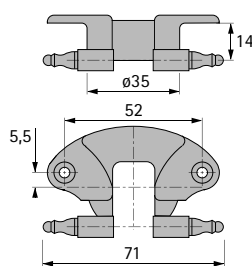

Cup dimensions  
 Intermat Konsul 5  
 with decorative finials

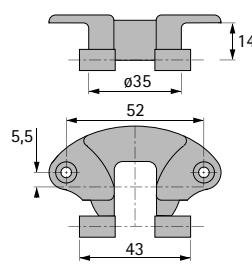

Cup dimensions  
 Intermat Konsul 5  
 without decorative finials

| Overlay mm | H mm |
|------------|------|
| 5          | 18,5 |

## Mounting plate system 9000 for Intermat Konsul 5

### Article

#### Screw-on wing mounting plate

Hole distance 32 mm, with oblong holes  $\varnothing 5,4$  mm for height adjustment, steel

PU = 50 pcs

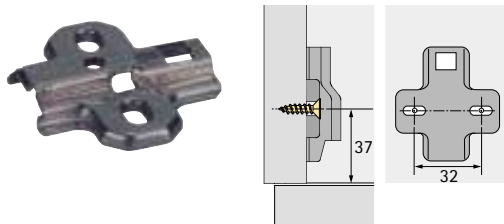

| Distance Hole line | Finish        | Distance | Total height | Order no. |
|--------------------|---------------|----------|--------------|-----------|
| 37 mm              | nickel-plated | 0 mm     | 9,0 mm       | 072 983   |
|                    | bronze-plated | 0 mm     | 9,0 mm       | 079 700   |
|                    | brass-plated  | 0 mm     | 9,0 mm       | 079 701   |

Fixing with countersunk wood screws  $\varnothing 4,5$  mm

#### Patented screw-on wing mounting plate "Hettich Direkt"

Hole distance 32 mm, with premounted locating pegs and asymmetrically positioned special screws for holes  $\varnothing 5 \times 7,5$  mm, oblong holes for height adjustment, steel

PU = 50 pcs

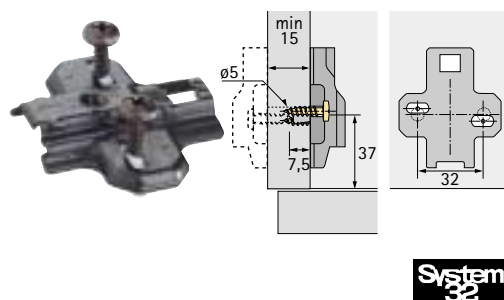

|       |               |      |        |         |
|-------|---------------|------|--------|---------|
| 37 mm | nickel-plated | 0 mm | 9,0 mm | 079 276 |
|       | bronze-plated | 0 mm | 9,0 mm | 079 702 |
|       | brass-plated  | 0 mm | 9,0 mm | 079 703 |







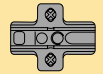

Technical information – see pages 3.16 - 3.19

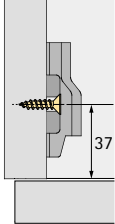
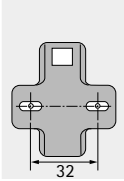
# Mounting plate system 9000 for Intermat and Ecomat hinges

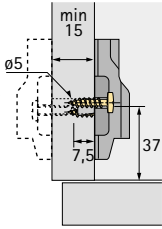
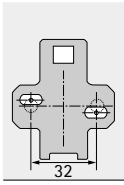
MPL 9000

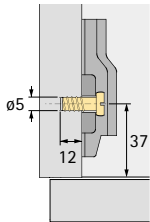
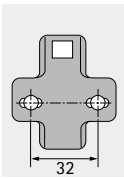

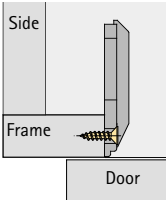
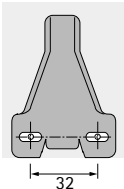
| Article   | Distance Hole line  | Distance  | Total height | Order no. |
|---|---|---|--------------|-----------|
| <b>Screw-on wing mounting plate</b><br>Hole distance 32 mm, with oblong holes $\varnothing$ 5,4 mm for height adjustment, nickel-plated steel/*die-cast zinc<br>PU = 50 pcs   |          | 0 mm  | 9,0 mm       | 072 983   |
|   |   | 1,5 mm  | 10,5 mm      | 072 984   |
|   |   | 3,0 mm  | 12,0 mm      | 072 985   |
|   |   | 5,0 mm  | 14,0 mm      | 072 986   |
|   |   | 8,0 mm*   | 17,0 mm      | 072 987   |
|   |   | 11,0 mm*  | 20,0 mm      | 077 946   |
| Fixing with countersunk wood screws $\varnothing$ 4,5 mm  |   |   |              |           |
| <b>Patented screw-on wing mounting plates "Hettich Direkt"</b><br>Half overlay applications from 15 mm side panel thickness possible, Hole distance 32 mm, with premounted locating pegs and asymmetrically positioned special screws for holes $\varnothing$ 5 x 7,5 mm, oblong holes for height adjustment, nickel-plated steel/*die-cast zinc<br>PU = 50 pcs |         | 0 mm  | 9,0 mm       | 079 276   |
|   |   | 1,5 mm  | 10,5 mm      | 079 277   |
|   |   | 3,0 mm  | 12,0 mm      | 078 926   |
|   |   | 5,0 mm  | 14,0 mm      | 079 278   |
|   |   | 8,0 mm*   | 17,0 mm      | 079 279   |
|   |   |  |              |           |
| <b>Screw-on wing mounting plate</b><br>Hole distance 32 mm, with premounted direct fixing screws for holes $\varnothing$ 5 x 12 mm oblong holes for height adjustment, nickel-plated steel/*die-cast zinc<br>PU = 50 pcs  |    | 0 mm  | 9,0 mm       | 079 374   |
|   |   | 1,5 mm  | 10,5 mm      | 079 375   |
|   |   | 3,0 mm  | 12,0 mm      | 079 376   |
|   |   | 5,0 mm  | 14,0 mm      | 079 377   |
|   |   | 8,0 mm*   | 17,0 mm      | 079 378   |
|   |   | 11,0 mm*  | 20,0 mm      | 079 379   |
|    |   |   |              |           |
| <b>Screw-on wing mounting plate</b><br>Hole distance 32 mm, for frame doors with overlay, oblong holes for height adjustment nickel-plated die-cast zinc<br>PU = 50 pcs   |    | 0 mm  | 8,2 mm       | 079 382   |
|   |   | 4,5 mm  | 12,7 mm      | 079 383   |
| Fixing with countersunk wood screws $\varnothing$ 4 mm  |   |   |              |           |

## Tungsten carbide tipped drill bit for 5 mm drill hole

| Article  | Order no. | PU |
|--|-----------|----|
| Tungsten carbide tipped drill bit for 5 mm drill holes | 046 083   | 1  |

# Mounting plate system 9000 for Intermat and Ecomat hinges with eccentric height adjustment

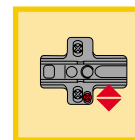
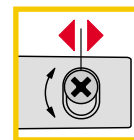

Article

Distance  
Hole line

Distance

Total  
height

Order no.

## Screw-on wing mounting plate "Hettich Top" for overlay mounting

with pre-mounted  
chipboard screws  
Eccentric height adjustment,  
nickel-plated die-cast zinc  
PU = 50 pcs

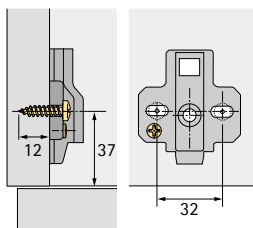
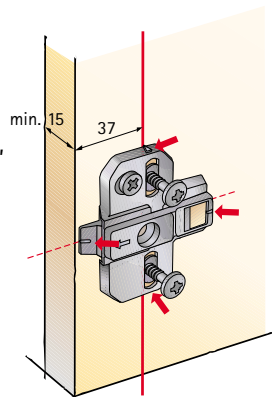

|       |        |         |         |
|-------|--------|---------|---------|
| 37 mm | 0 mm   | 8,3 mm  | 043 021 |
|       | 1,5 mm | 9,8 mm  | 043 022 |
|       | 3,0 mm | 11,3 mm | 043 023 |
|       | 5,0 mm | 13,3 mm | 043 024 |
|       | 8,0 mm | 14,3 mm | 043 025 |

## Screw-on wing mounting plate "Hettich Top" for half overlay mounting

possible from 15 mm side panel thickness  
with pre-mounted chipboard screws  
Eccentric height adjustment,  
nickel-plated die-cast zinc  
PU = 50 pcs

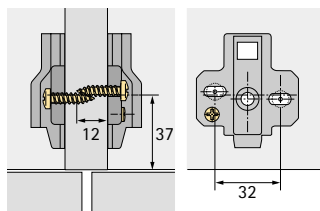
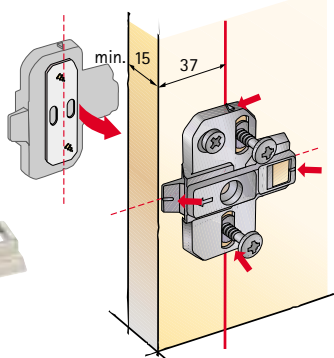

|       |        |         |         |
|-------|--------|---------|---------|
| 37 mm | 0 mm   | 8,3 mm  | 043 026 |
|       | 1,5 mm | 9,8 mm  | 043 027 |
|       | 3,0 mm | 11,3 mm | 043 028 |
|       | 5,0 mm | 13,3 mm | 043 029 |
|       | 8,0 mm | 14,3 mm | 043 031 |



**Hole marking template** for screw-on cross  
mounting plates with pre-mounted chipboard  
screws **for half overlay applications**,  
Order no. 045 150, PU = 1 pc

## Patented screw-on wing mounting plates "Hettich Direkt Top"

Half overlay applications from  
15 mm side panel thickness possible  
Hole distance 32 mm,  
with pre-mounted locating pegs  
and asymmetrically positioned  
special screws for drilling  $\varnothing 5 \times 7,5$  mm,  
Eccentric height adjustment,  
nickel-plated die-cast zinc  
PU = 50 pcs

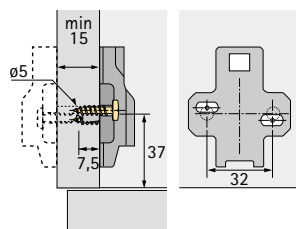

System  
32

|       |        |         |         |
|-------|--------|---------|---------|
| 37 mm | 0 mm   | 8,3 mm  | 020 009 |
|       | 1,5 mm | 9,8 mm  | 020 010 |
|       | 3,0 mm | 11,3 mm | 020 011 |
|       | 5,0 mm | 13,3 mm | 020 012 |
|       | 8,0 mm | 14,3 mm | 020 013 |

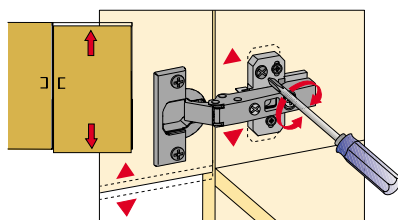

# System 9000 mounting plates/angle mounting plates for Intermat and Ecomat hinges

MPL 9000



| Article   |  | Distance Hole line                                       | Distance | Total height | Order no.  |
|---|--|--|----------|--------------|--|
| <b>InLine screw-on mounting plates</b><br>Hole distance 32 mm for direct fixing with chipboard screw $\varnothing$ 3,5 mm, <b>parallel</b> eccentric height adjustment, nickel-plated steel/*die-cast zinc<br>PU = 50 pcs |  | 20 mm  | 1,5 mm   | 9,5 mm       | 043 017  |
|   |  |  | 3,0 mm   | 11,0 mm      | 043 018  |
|   |  |  | 5,0 mm   | 13,0 mm      | 043 019  |
| <b>InLine knock-in mounting plates</b><br>Hole distance 32 mm knock-in version for drill holes dia. 10 x 11,5 mm <b>parallel</b> eccentric height adjustment, nickel-plated steel/*die-cast zinc<br>PU = 50 pcs           |  | 20 mm  | 1,5 mm   | 9,5 mm       | 042 814  |
|   |  |  | 3,0 mm   | 11,0 mm      | 042 813  |
|   |  |  | 5,0 mm   | 13,0 mm      | 042 815  |
| <b>Angle plate for wing mounting plate</b><br>silver-grey plastic<br>PU = 50 pcs  |  | 37 mm  | 5°       | 5,0 mm       | 079 349  |
|   |  |  | 10°      | 10,0 mm      | 079 350  |
| <b>Angle plates may only be used with the following wing mounting plates:</b>   |  |  |          |              | Simply turn the plastic angle mounting plates to either increase or decrease the cabinet angle. Plastic angle mounting plates are stackable. |
| <b>Screw-on wing mounting plate</b><br>Hole distance 32 mm, with oblong holes $\varnothing$ 5,4 mm for height adjustment, nickel-plated steel/*die-cast zinc<br>PU = 50 pcs   |  | 37 mm  | 0 mm     | 9,0 mm       | 072 983  |
|   |  |  | 1,5 mm   | 10,5 mm      | 072 984  |
|   |  |  | 3,0 mm   | 12,0 mm      | 072 985  |
|   |  |  | 5,0 mm   | 14,0 mm      | 072 986  |
|   |  |  | 8,0 mm*  | 17,0 mm      | 072 987  |
|   |  |  | 11,0 mm* | 20,0 mm      | 077 946  |
|   |  | Fixing with countersunk wood screws $\varnothing$ 4,5 mm |          |              |  |

## Assembly note angle plates 5°/10°:

### 1. Sockets



Socket no. 41  
Order no. 048 575  
PU 200 pcs

or

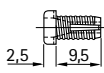

Socket no. 42  
Order no. 048 574  
PU 200 pcs

Insert in  $\varnothing$  5 mm hole line drilling



### 2. Mounting and angle plates

Fasten with chipboard screws  $\varnothing$  4 mm or  $\varnothing$  4,5 mm.

**A trial mounting is always recommended for configurations of this type!**

# System 9000 angle and parallel adapter for Intermat and Ecomat hinges

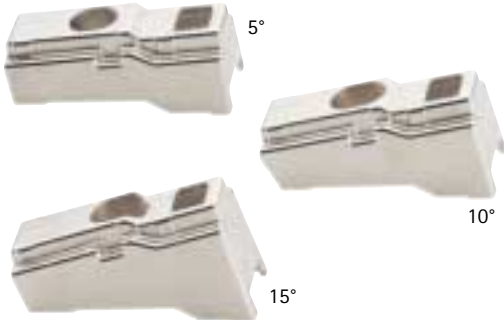
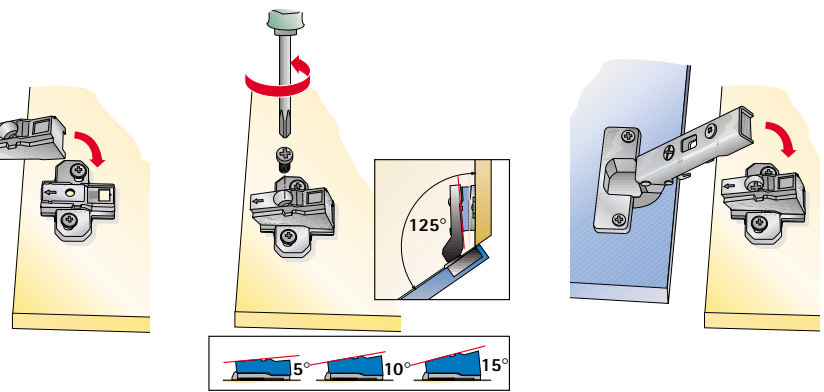

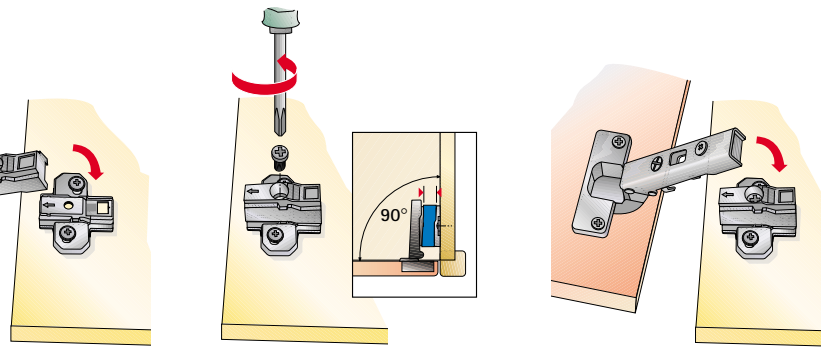
| Article  | Distance Hole line | Distance         | Total height                  | Order no.                     |
|--|--------------------|------------------|-------------------------------|-------------------------------|
| <p><b>Angle adapter for wing mounting plates</b><br/>nickel-plated die-cast zinc<br/>PU = 50 pcs<br/>1 PU contains<br/>50 angle plates and<br/>50 fixing screws</p>              | 37 mm              | 5°<br>10°<br>15° | 17,4 mm<br>21,4 mm<br>25,4 mm | 043 036<br>043 037<br>043 038 |
| <p>When using the die-cast zinc angle adapter, the cabinet angle can only be increased. Die-cast zinc angle adapters are not stackable.</p>  |                    |                  |                               |                               |
| <p><b>Parallel adapter for wing mounting plates</b><br/>nickel-plated die-cast zinc<br/>PU = 50 pcs<br/>1 PU contains<br/>50 parallel adapters and<br/>50 fixing screws</p>   | 37 mm              | 12 mm<br>22 mm   | 17,6 mm<br>27,6 mm            | 043 032<br>043 033            |
| <p>A trial mounting is always recommended for configurations of this type!</p> <p>Angle adapters and parallel adapters can be used with all the cross mounting plates on pages 3.110 – except order no. 079382 and 079383.</p>   |                    |                  |                               |                               |

# Accessories

**Cover cap**  
for Intermat hinges

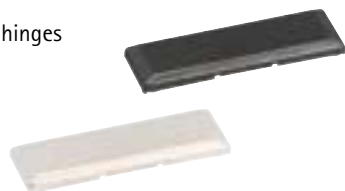

**Cover cap**  
for Ecomat hinges



| Article                       | Finish              | Order no. | PU |
|-------------------------------|---------------------|-----------|----|
| Cover cap for Intermat hinges | nickel-plated steel | 013 300   | 50 |
|                               | black plastic       | 048 043   | 50 |

| Article                     | Finish              | Order no. | PU |
|-----------------------------|---------------------|-----------|----|
| Cover cap for Ecomat hinges | nickel-plated steel | 079 790   | 50 |

**Fixing screws**  
for hinges, mounting plates and sockets

| Artikel  | Bestell-Nr. | PU   |
|--|-------------|------|
| Cup fixing for T42,<br>3,5 x 13 mm                         | 048 296     | 200  |
| Countersunk fixing screw<br>3,5 x 9,5 mm<br>for alu hinges | 041 296     | 200  |
| Intermat glass door fixing screw                           | 069 611     | 1000 |



**Cover cap 35**  
for hole diameter  
35 mm

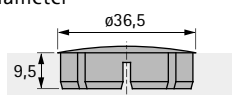

| Article      | Finish        | Order no. | PU  |
|--------------|---------------|-----------|-----|
| Cover cap 35 | white plastic | 025 204   | 100 |
|              | brown plastic | 025 205   | 100 |
|              | black plastic | 071 832   | 100 |

**Stop attachment**  
for hole diameter  
6 mm

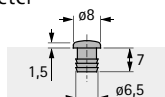

| Article         | Finish        | Order no. | PU   |
|-----------------|---------------|-----------|------|
| Stop attachment | white plastic | 025 048   | 1000 |
|                 | brown plastic | 021 154   | 1000 |
|                 | beige plastic | 047 353   | 1000 |



**Stop attachment, self-adhesive**  
ø 8 mm

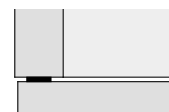

| Article                        | Finish        | Order no. | PU   |
|--------------------------------|---------------|-----------|------|
| Stop attachment, self-adhesive | clear plastic | 072 120   | 50   |
|                                | clear plastic | 046 695   | 1000 |

# Mounting configurations for 40° to 160° face angles

## Intermat



The following pages list **107 mounting configurations** for cabinet face angles from 40° to 160° with different door and side designs.

These door situations can be achieved with the **Intermat** hinge range, in particular the W hinge versions, using the appropriate mounting plates, angle and parallel adapters and stackable angle mounting plates.

All mounting configurations feature the **T42 cup version**. All hinges can also be mounted using **other cup versions** (T 43, TB 43, Flash, T FIX, TH FIX or TB FIX).

3

A trial mounting is always recommended for mounting configurations of this type !



... over 100 mounting configurations for different face angles from 40° - 160°. Door and side variations with detailed parts lists cover practical construction aids for the furniture maker.

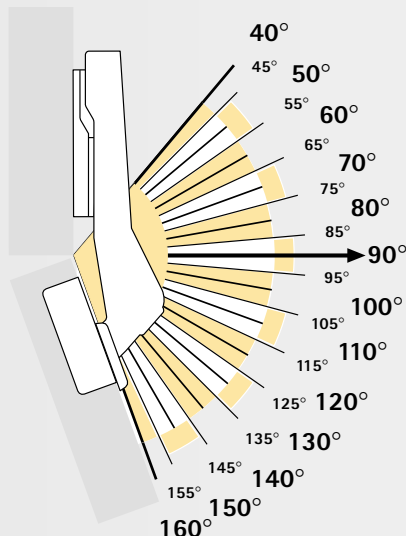

Order our poster  
in format 80 x 130 cm  
Order no.: 049 000

Face angles  
from 40° to 160°,  
graded in  
5° steps.

# Intermat mounting configurations for cabinet face angles ...

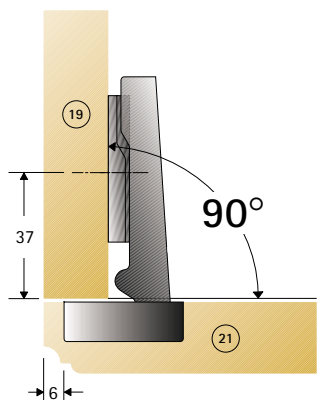

**Intermat 9943**

Cranking 0 mm  
Mounting plate distance 0 mm

Order no. 048 049  
Order no. 072 983

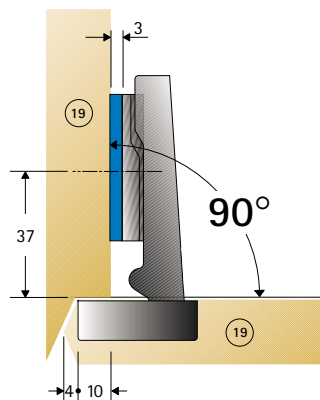

**Intermat 9943**

Cranking 0 mm  
Mounting plate distance 3 mm

Order no. 048 049  
Order no. 072 985

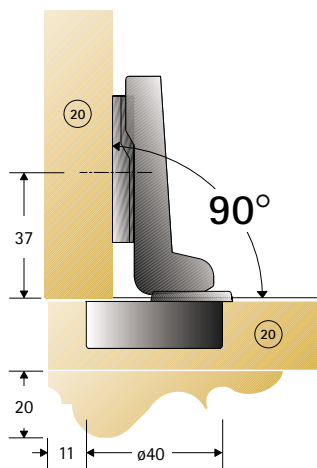

**Intermat 9935**

Cranking 5 mm  
Mounting plate distance 0 mm

Order no. 073 926  
Order no. 072 983

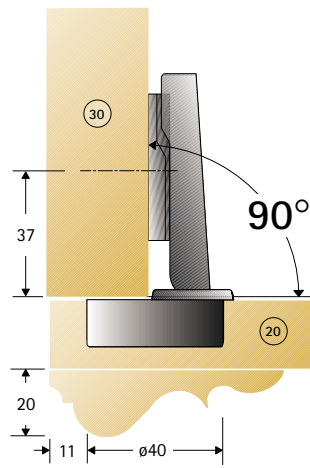

**Intermat 9935**

Cranking - 5 mm  
Mounting plate distance 0 mm

Order no. 073 925  
Order no. 072 983

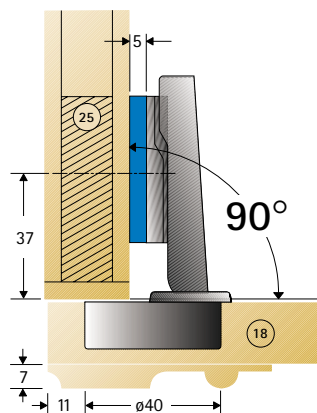

**Intermat 9935**

Cranking - 5 mm  
Mounting plate distance 5 mm

Order no. 073 925  
Order no. 072 986

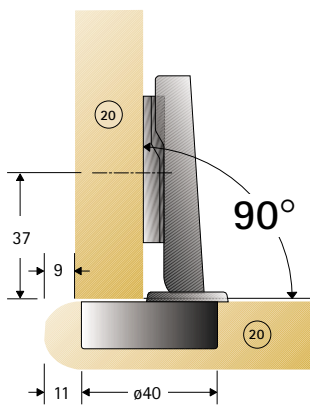

**Intermat 9935**

Cranking - 5 mm  
Mounting plate distance 0 mm

Order no. 073 925  
Order no. 072 983

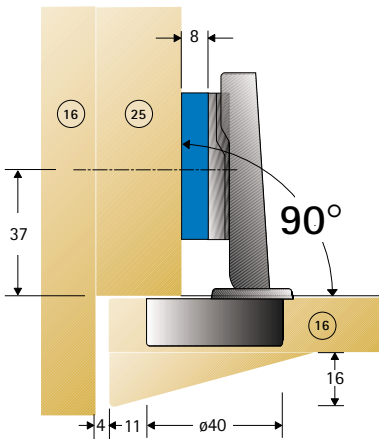

**Interimat 9935**

Cranking - 5 mm  
Mounting plate distance 8 mm

Order no. 073 925  
Order no. 072 987

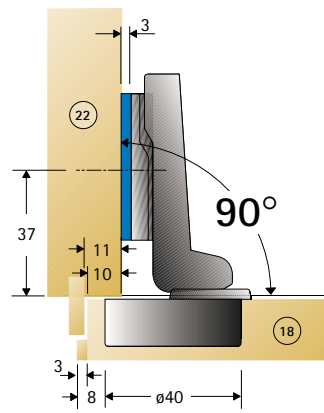

**Interimat 9935**

Cranking 5 mm  
Mounting plate distance 3 mm

Order no. 073 926  
Order no. 072 985

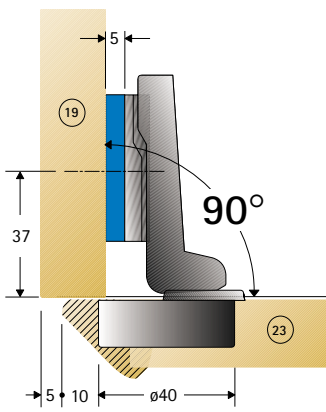

**Interimat 9935**

Cranking 5 mm  
Mounting plate distance 5 mm

Order no. 073 926  
Order no. 072 986

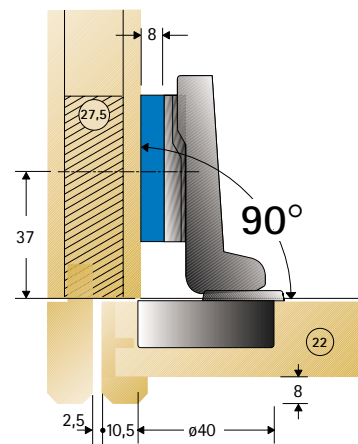

**Interimat 9935**

Cranking 5 mm  
Mounting plate distance 8 mm

Order no. 073 926  
Order no. 072 987

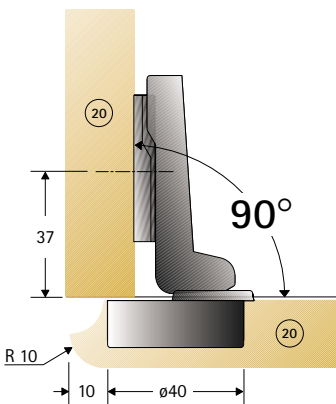

**Interimat 9935**

Cranking 5 mm  
Mounting plate distance 0 mm

Order no. 073 926  
Order no. 072 983

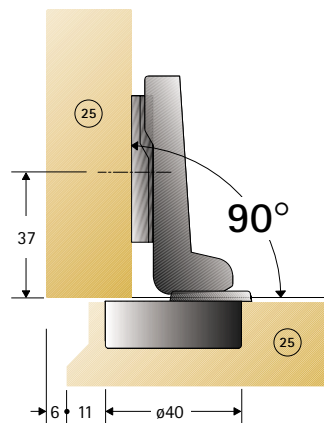

**Interimat 9935**

Cranking 5 mm  
Mounting plate distance 0 mm

Order no. 073 926  
Order no. 072 983

# Intermat mounting configurations for cabinet face angles ...

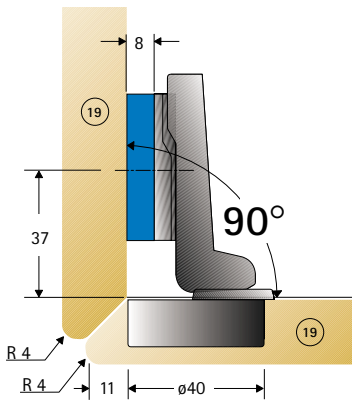

## Intermat 9935

Cranking 5 mm

Mounting plate distance 8 mm

Order no. 073 926

Order no. 072 987

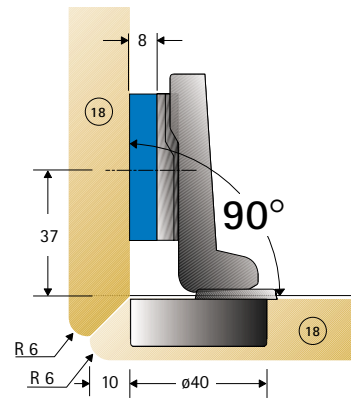

## Intermat 9935

Cranking 5 mm

Mounting plate distance 8 mm

Order no. 073 926

Order no. 072 987

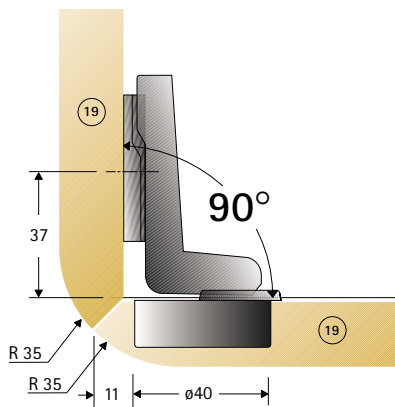

## Intermat 9935

Cranking 16 mm

Mounting plate distance 0 mm

Order no. 073 927

Order no. 072 983

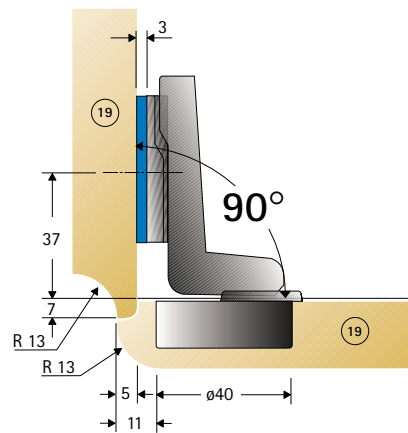

## Intermat 9935

Cranking 16 mm

Mounting plate distance 3 mm

Order no. 073 927

Order no. 072 985

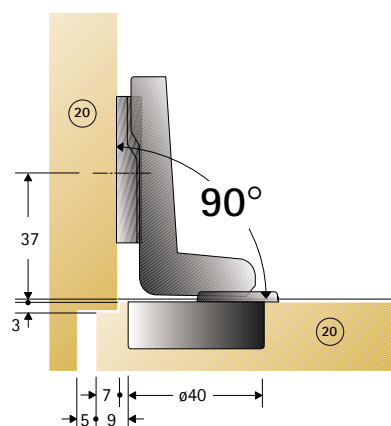

## Intermat 9935

Cranking 16 mm

Mounting plate distance 0 mm

Order no. 073 927

Order no. 072 983

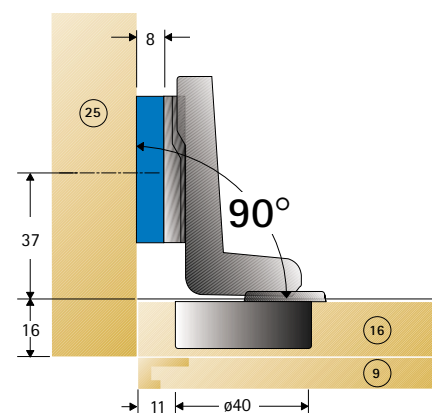

## Intermat 9935

Cranking 16 mm

Mounting plate distance 8 mm

Order no. 073 927

Order no. 072 987

3

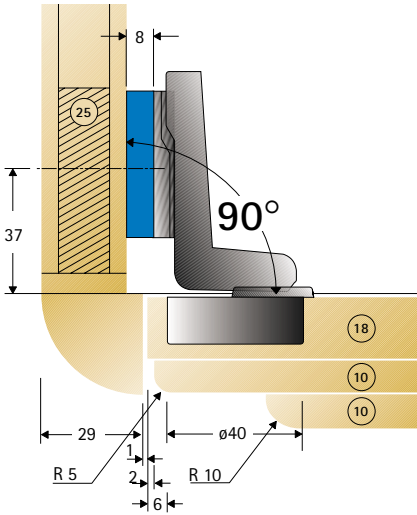

**Intermat 9935**

Cranking 16 mm  
Mounting plate distance 8 mm

Order no. 073 927  
Order no. 072 987

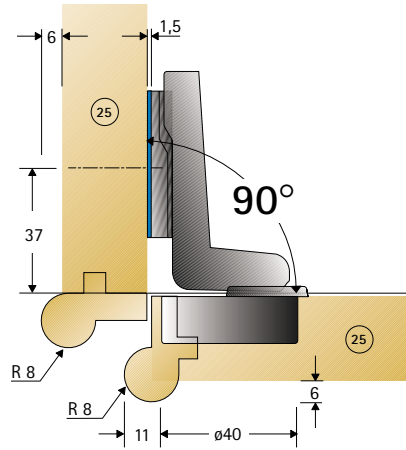

**Intermat 9935**

Cranking 16 mm  
Mounting plate distance 1,5 mm

Order no. 073 927  
Order no. 072 984

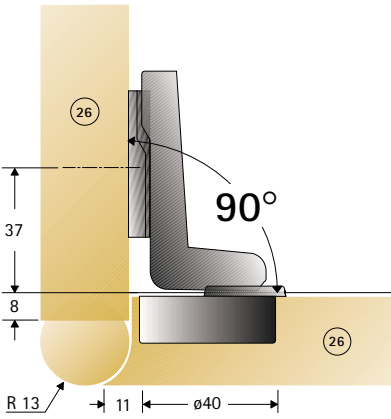

**Intermat 9935**

Cranking 16 mm  
Mounting plate distance 0 mm

Order no. 073 927  
Order no. 072 983

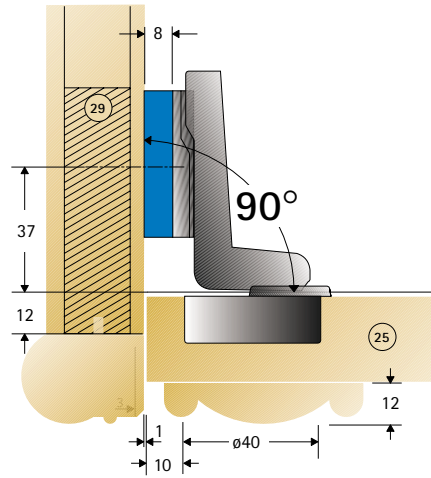

**Intermat 9935**

Cranking 16 mm  
Mounting plate distance 8 mm

Order no. 073 927  
Order no. 072 987

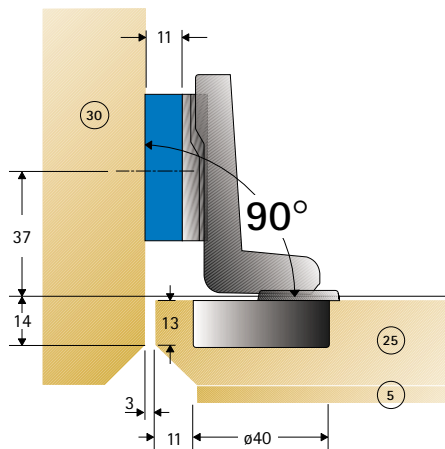

**Intermat 9935**

Cranking 16 mm  
Mounting plate distance 11 mm

Order no. 073 927  
Order no. 077 946

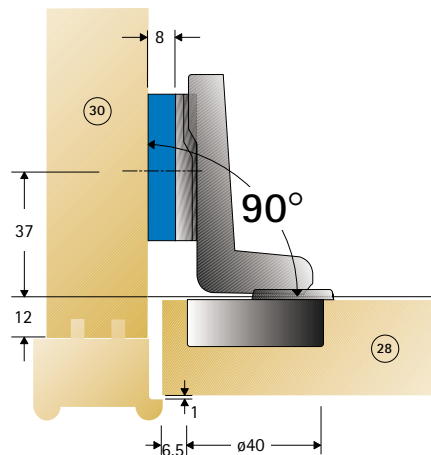

**Intermat 9935**

Cranking 16 mm  
Mounting plate distance 8 mm

Order no. 073 927  
Order no. 072 987

# Intermat mounting configurations for cabinet face angles... and face frame

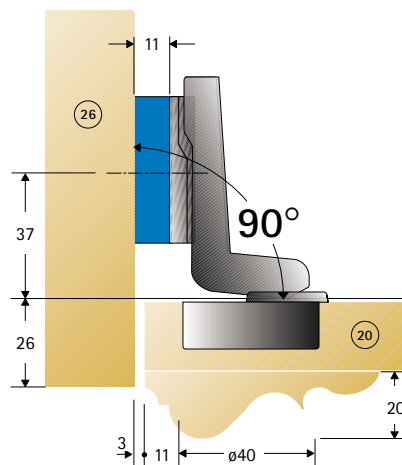
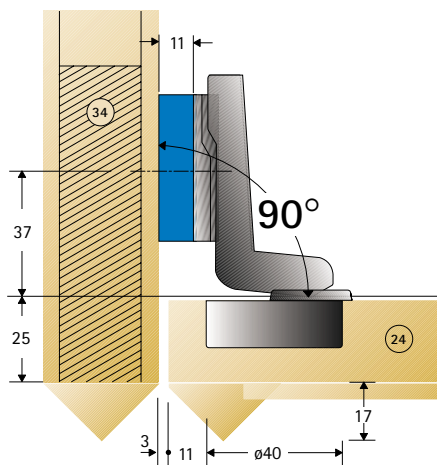

## Intermat 9935

Cranking 16 mm      Order no. 073 927  
 Mounting plate distance 11 mm      Order no. 077 946

## Intermat 9935

Cranking 16 mm      Order no. 073 927  
 Mounting plate distance 11 mm      Order no. 077 946

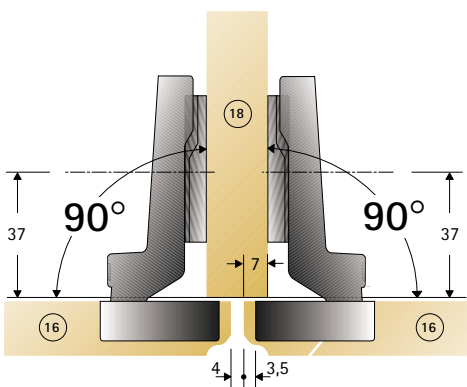

## Intermat 9943

Cranking 9,5 mm      Order no. 048 051  
 Mounting plate distance 0 mm      Order no. 072 983

## Intermat 9943

Cranking 9,5 mm      Order no. 048 051  
 Mounting plate distance 0 mm      Order no. 072 983

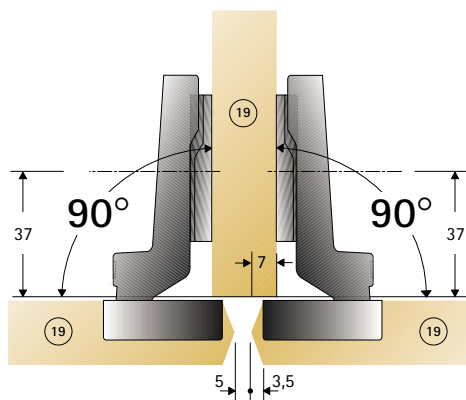

## Intermat 9943

Cranking 9,5 mm      Order no. 048 051  
 Mounting plate distance 0 mm      Order no. 072 983

## Intermat 9943

Cranking 9,5 mm      Order no. 048 051  
 Mounting plate distance 0 mm      Order no. 072 983

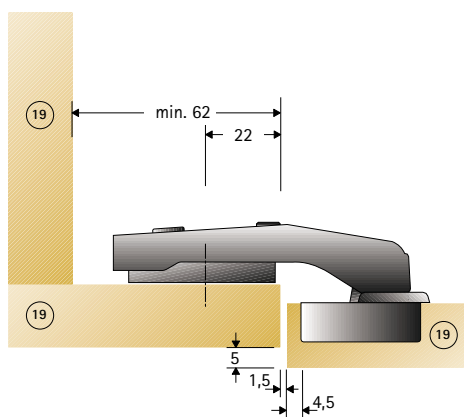

## Intermat 9936 W90

Cranking 5 mm      Order no. 077 708  
 Mounting plate distance 0 mm      Order no. 072 983

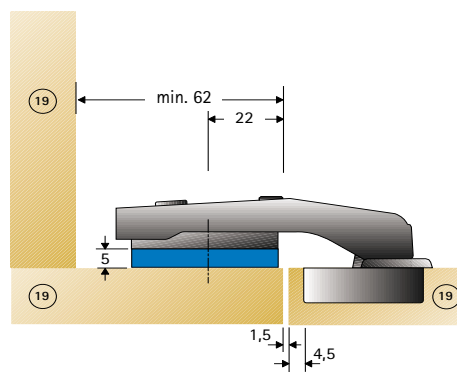

## Intermat 9936 W90

Cranking 5 mm      Order no. 077 708  
 Mounting plate distance 5 mm      Order no. 072 986

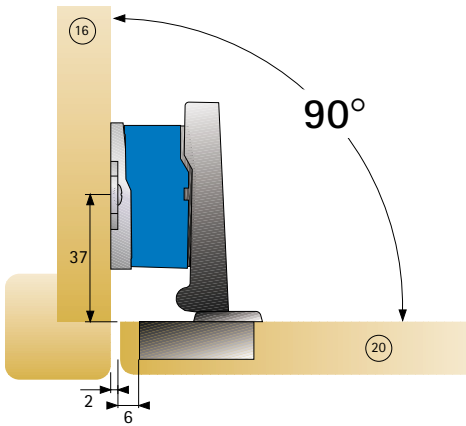

**Intermat 9936**

Cranking 0 mm                      Order no. 073913  
 Mounting plate distance 8 mm      Order no. 072987  
 Parallel adapter distance 12 mm    Order no. 043032

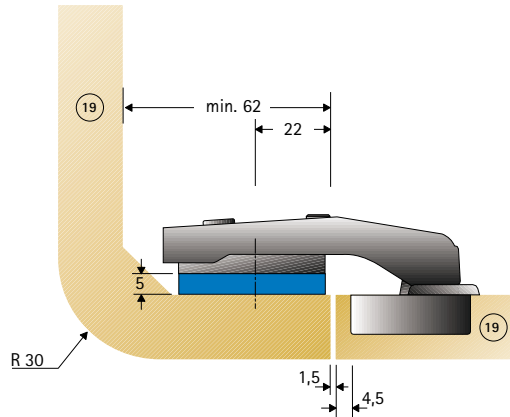

**Intermat 9936 W90**

Cranking 5 mm                      Order no. 077708  
 Mounting plate distance 5 mm      Order no. 072986

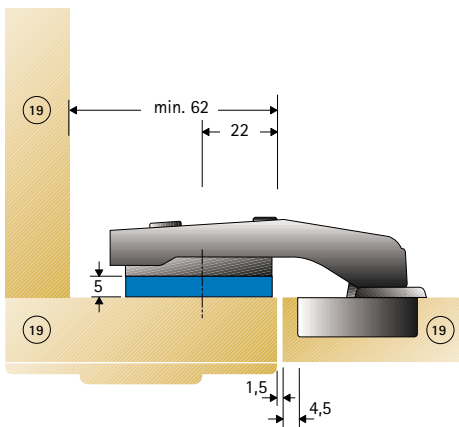

**Intermat 9936 W90**

Cranking 5 mm                      Order no. 077708  
 Mounting plate distance 5 mm      Order no. 072986

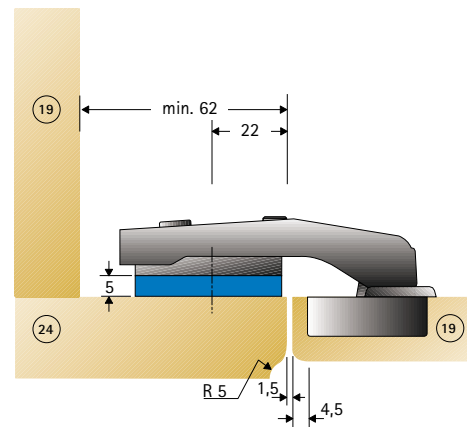

**Intermat 9936 W90**

Cranking 5 mm                      Order no. 077708  
 Mounting plate distance 5 mm      Order no. 072986

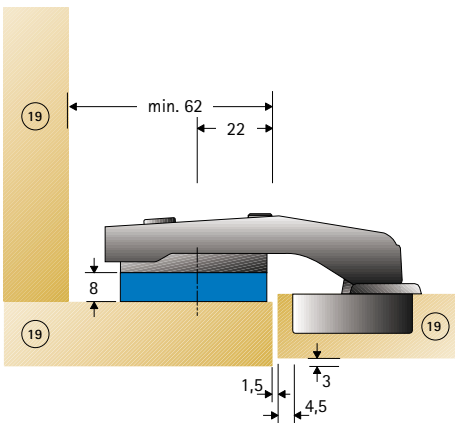

**Intermat 9936 W90**

Cranking 5 mm                      Order no. 077708  
 Mounting plate distance 8 mm      Order no. 072987

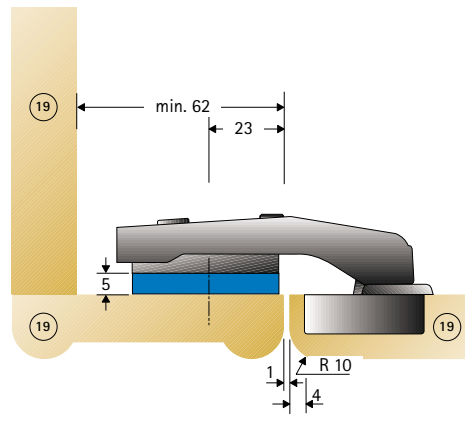

**Intermat 9936 W90**

Cranking 5 mm                      Order no. 077708  
 Mounting plate distance 5 mm      Order no. 072986

# Intermat mounting configurations for cabinet face angles...

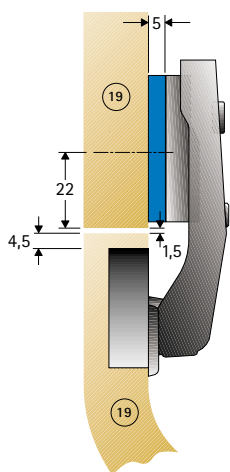

**Intermat 9936 W90**

Cranking 5 mm

Mounting plate distance 5 mm

Order no. 077 708

Order no. 072 986

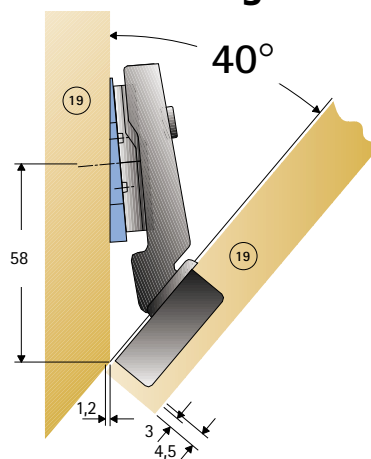

**Intermat 9944 W-45**

Cranking 10 mm

Mounting plate distance 0 mm

Angle plate 5°

Order no. 077 643

Order no. 072 983

Order no. 079 349

3

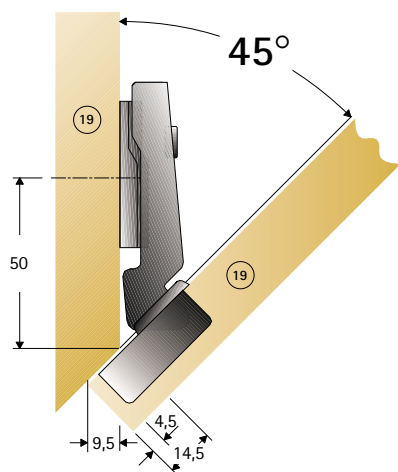

**Intermat 9944 W-45**

Cranking 10 mm

Mounting plate distance 0 mm

Order no. 077 643

Order no. 072 983

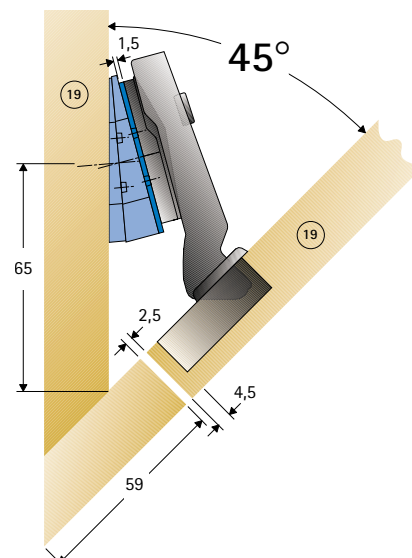

**Intermat 9944 W-30**

Cranking 12 mm

Mounting plate distance 1,5 mm

Angle plate 5°

Angle plate 10°

Order no. 073 936

Order no. 072 984

Order no. 079 349

Order no. 079 350

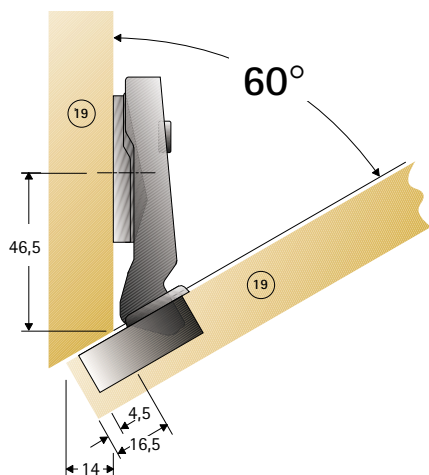

**Intermat 9944 W-30**

Cranking 12 mm

Mounting plate distance 0 mm

Order no. 073 936

Order no. 072 983

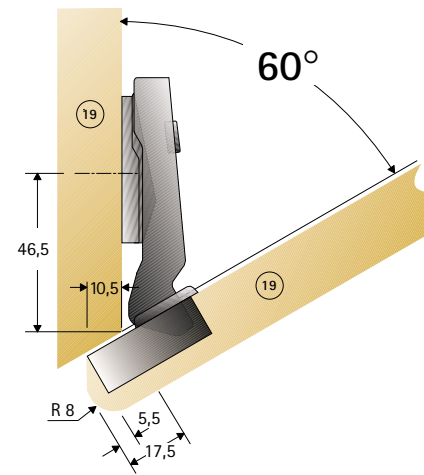

**Intermat 9944 W-30**

Cranking 12 mm

Mounting plate distance 0 mm

Order no. 073 936

Order no. 072 983

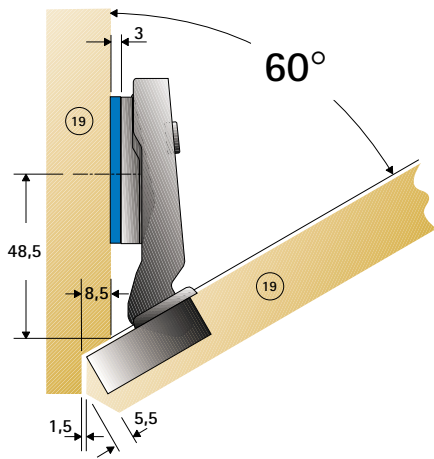

**Intermat 9944 W-30**

Cranking 12 mm

Mounting plate distance 3 mm

Order no. 073 936

Order no. 072 985

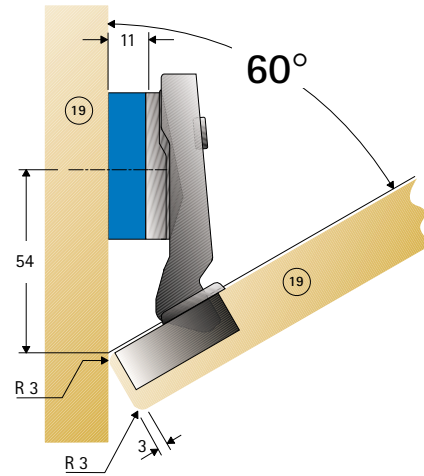

**Intermat 9944 W-30**

Cranking 12 mm

Mounting plate distance 11 mm

Order no. 073 936

Order no. 077 946

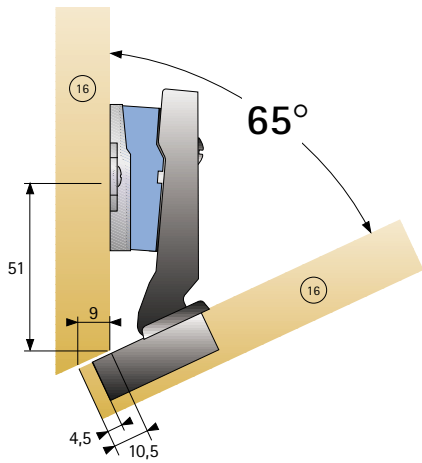

**Intermat 9944 W-30**

Cranking 12 mm

Mounting plate distance 0 mm

Angle adapter 5°

Order no. 073 936

Order no. 072 983

Order no. 043 036

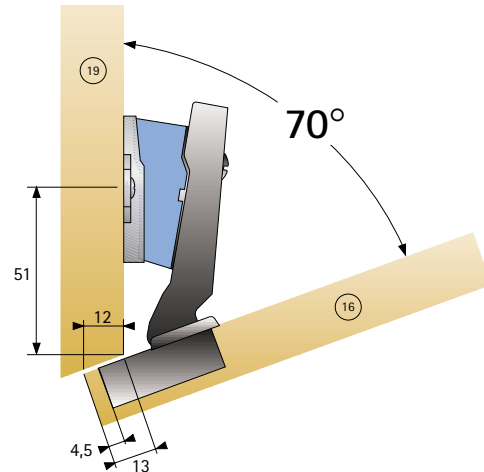

**Intermat 9944 W-30**

Cranking 12 mm

Mounting plate distance 0 mm

Angle adapter 10°

Order no. 073 936

Order no. 072 983

Order no. 043 037

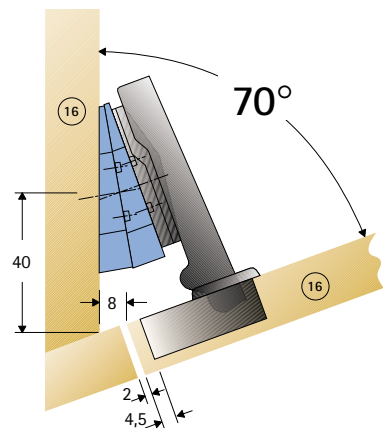

**Intermat 9943**

Cranking 0 mm

Mounting plate distance 0 mm

2 x angle plate 10°

Order no. 048 049

Order no. 072 983

Order no. 079 350

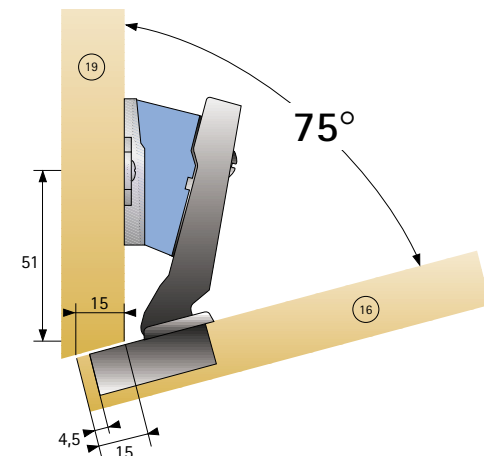

**Intermat 9944 W-30**

Cranking 12 mm

Mounting plate distance 0 mm

Angle adapter 15°

Order no. 073 936

Order no. 072 983

Order no. 043 038

# Intermat mounting solutions for cabinet face angles...

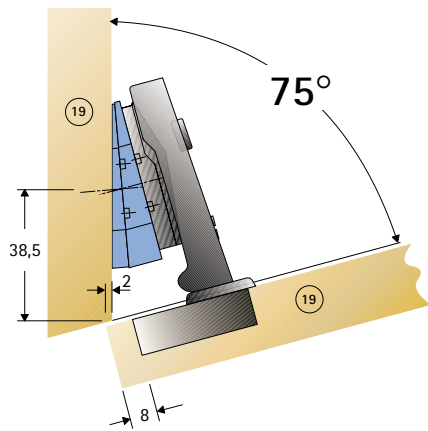

## Intermat 9936

Cranking 0 mm  
 Mounting plate distance 0 mm  
 Angle plate 10°  
 Angle plate 5°

Order no. 073 913  
 Order no. 072 983  
 Order no. 079 350  
 Order no. 079 349

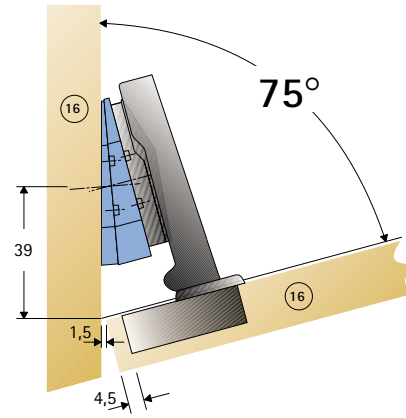

## Intermat 9943

Cranking 0 mm  
 Mounting plate distance 0 mm  
 Angle plate 10°  
 Angle plate 5°

Order no. 048 049  
 Order no. 072 983  
 Order no. 079 350  
 Order no. 079 349

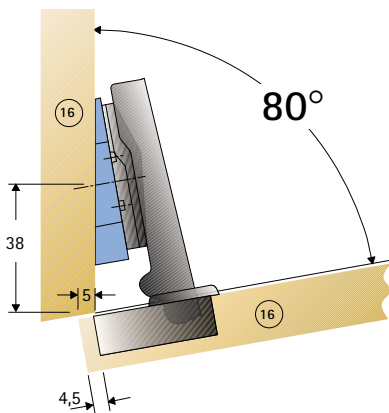

## Intermat 9943

Cranking 0 mm  
 Mounting plate distance 0 mm  
 Angle plate 10°

Order no. 048 049  
 Order no. 072 983  
 Order no. 079 350

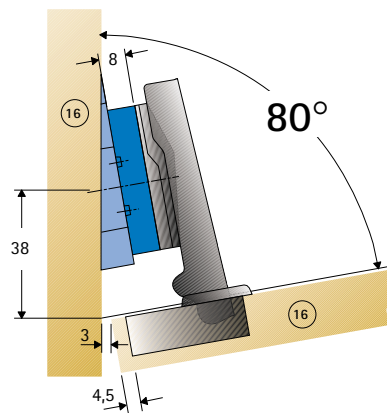

## Intermat 9943

Cranking 0 mm  
 Mounting plate distance 8 mm  
 Angle plate 10°

Order no. 048 049  
 Order no. 072 987  
 Order no. 079 350

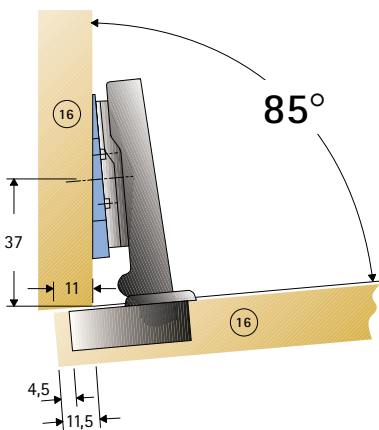

## Intermat 9943

Cranking 0 mm  
 Mounting plate distance 0 mm  
 Angle plate 5°

Order no. 048 049  
 Order no. 072 983  
 Order no. 079 349

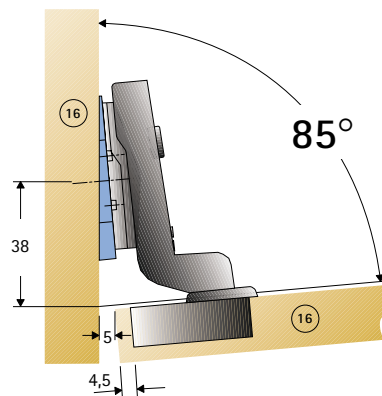

## Intermat 9943

Cranking 16 mm  
 Mounting plate distance 0 mm  
 Angle plate 5°

Order no. 048 052  
 Order no. 072 983  
 Order no. 079 349

3

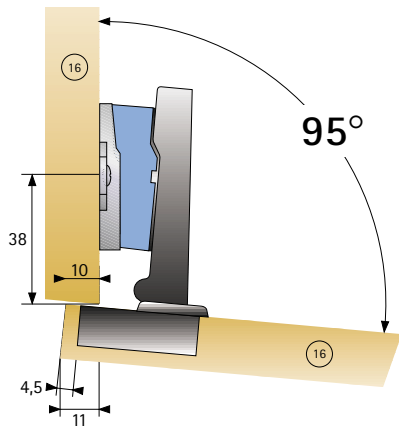

**Intermat 9943**

Cranking 0 mm  
 Mounting plate distance 0 mm  
 Angle adapter 5°

Order no. 048 049  
 Order no. 072 983  
 Order no. 043 036

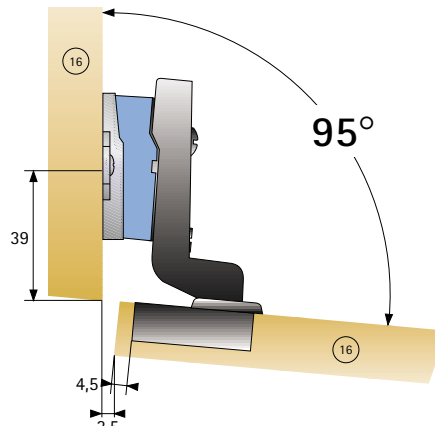

**Intermat 9943**

Cranking 16 mm  
 Mounting plate distance 0 mm  
 Angle adapter 5°

Order no. 048 052  
 Order no. 072 983  
 Order no. 043 036

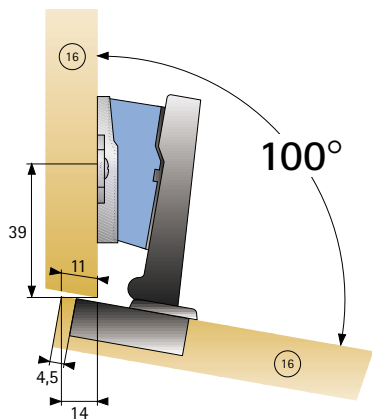

**Intermat 9943**

Cranking 0 mm  
 Mounting plate distance 0 mm  
 Angle adapter 10°

Order no. 048 049  
 Order no. 072 983  
 Order no. 043 037

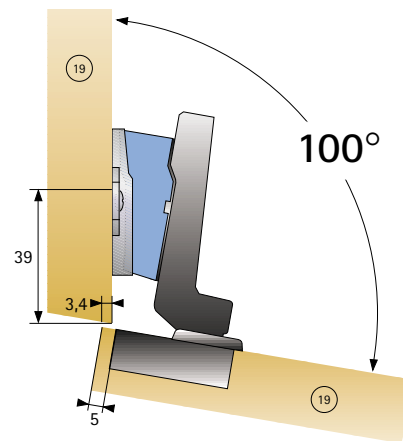

**Intermat 9943**

Cranking 9,5 mm  
 Mounting plate distance 0 mm  
 Angle adapter 10°

Order no. 048 051  
 Order no. 072 983  
 Order no. 043 037

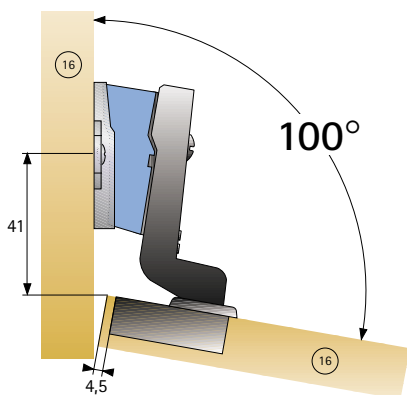

**Intermat 9943**

Cranking 16 mm  
 Mounting plate distance 0 mm  
 Angle adapter 10°

Order no. 048 052  
 Order no. 072 983  
 Order no. 043 037

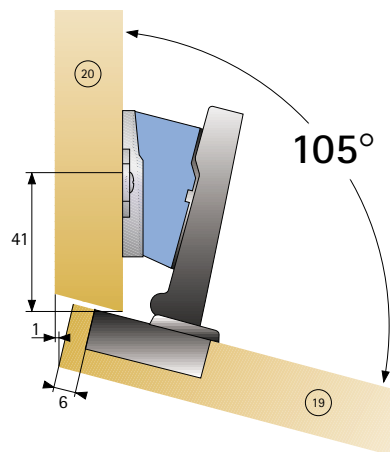

**Intermat 9943**

Cranking 0 mm  
 Mounting plate distance 0 mm  
 Angle adapter 15°

Order no. 048 049  
 Order no. 072 983  
 Order no. 043 038

# Intermat mounting solutions for cabinet face angles...

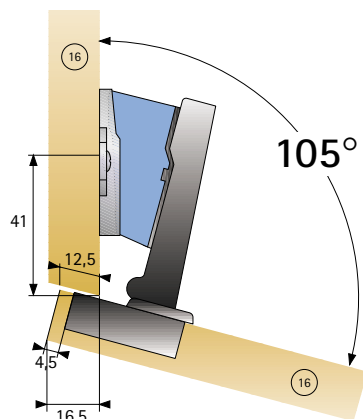

## Intermat 9943

Cranking 0 mm  
Mounting plate distance 0 mm  
Angle adapter 15°

Order no. 048 049  
Order no. 072 983  
Order no. 043 038

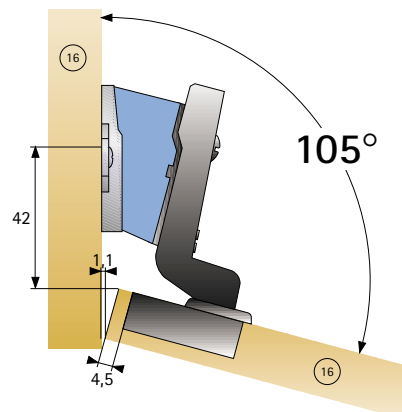

## Intermat 9943

Cranking 16 mm  
Mounting plate distance 3 mm  
Angle adapter 15°

Order no. 048 052  
Order no. 072 985  
Order no. 043 038

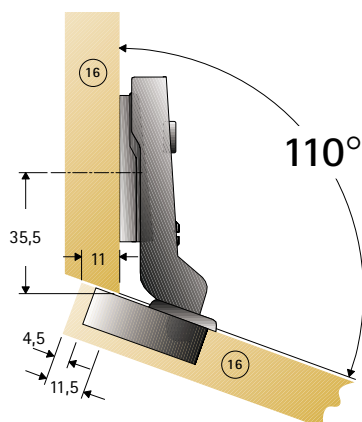

## Intermat 9936 W20

Cranking 7 mm  
Mounting plate distance 0 mm

Order no. 077 644  
Order no. 072 983

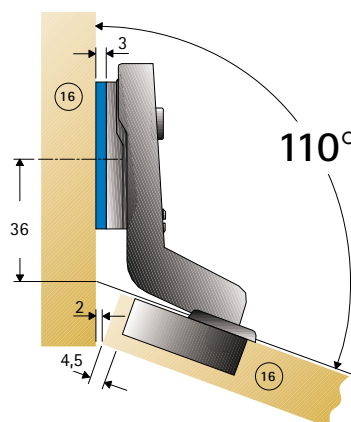

## Intermat 9936 W20

Cranking -9 mm  
Mounting plate distance 3 mm

Order no. 077 645  
Order no. 072 985

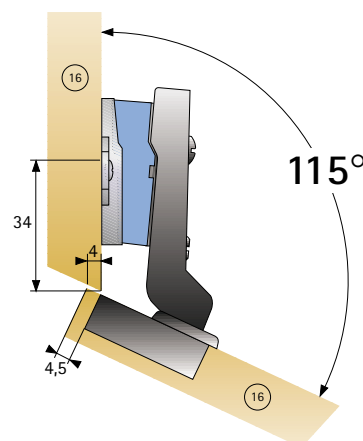

## Intermat 9936 W20

Cranking 7 mm  
Mounting plate distance 0 mm  
Angle adapter 5°

Order no. 077 644  
Order no. 072 983  
Order no. 043 036

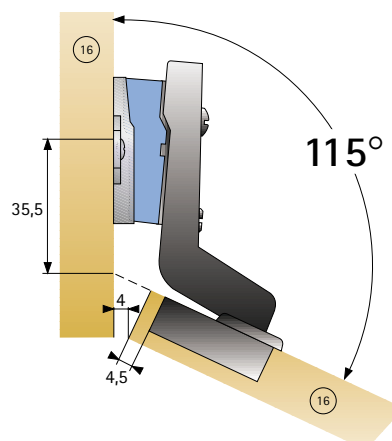

## Intermat 9936 W20

Cranking -9 mm  
Mounting plate distance 0 mm  
Angle adapter 5°

Order no. 077 645  
Order no. 072 983  
Order no. 043 036

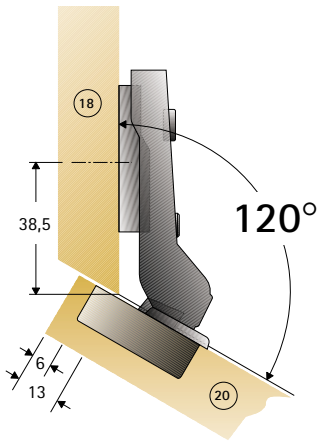

**Intermat 9936 W30**

Cranking 7 mm  
Mounting plate distance 0 mm

Order no. 077 690  
Order no. 072 983

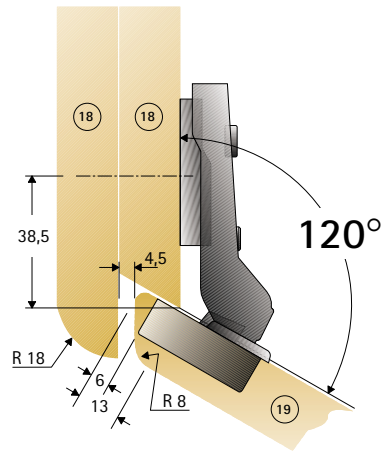

**Intermat 9936 W30**

Cranking 7 mm  
Mounting plate distance 0 mm

Order no. 077 690  
Order no. 072 983

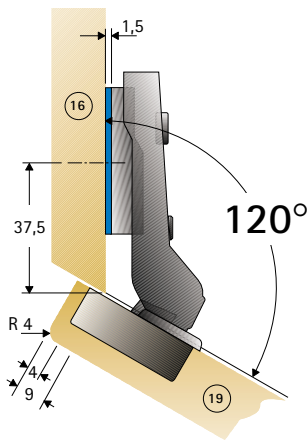

**Intermat 9936 W30**

Cranking 7 mm  
Mounting plate distance 1,5 mm

Order no. 077 690  
Order no. 072 984

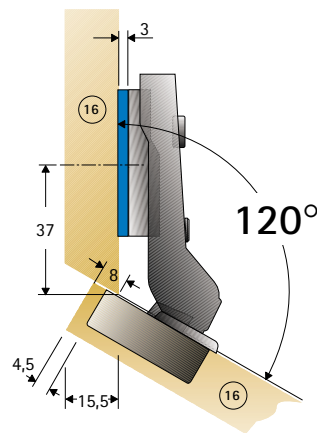

**Intermat 9936 W30**

Cranking 7 mm  
Mounting plate distance 3 mm

Order no. 077 690  
Order no. 072 985

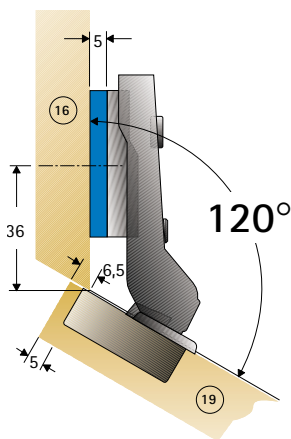

**Intermat 9936 W30**

Cranking 7 mm  
Mounting plate distance 5 mm

Order no. 077 690  
Order no. 072 986

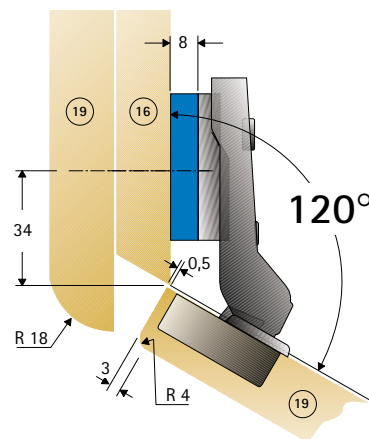

**Intermat 9936 W30**

Cranking 7 mm  
Mounting plate distance 8 mm

Order no. 077 690  
Order no. 072 987

# Intermat mounting solutions for cabinet face angles...

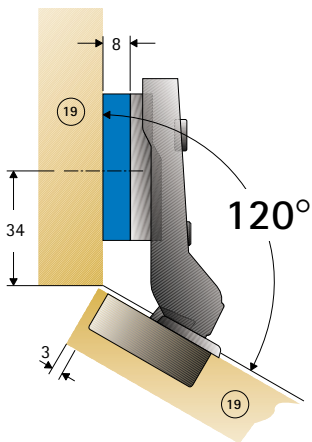

## Intermat 9936 W30

Cranking 7 mm  
Mounting plate distance 8 mm

Order no. 077 690  
Order no. 072 987

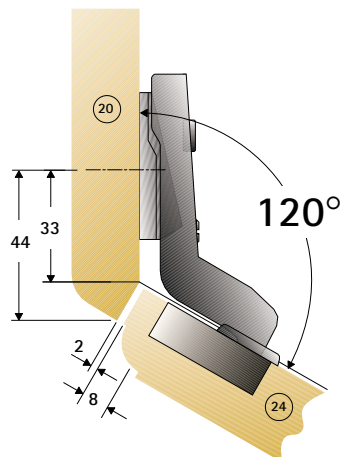

## Intermat 9936 W30

Cranking - 10 mm  
Mounting plate distance 0 mm

Order no. 073 928  
Order no. 072 983

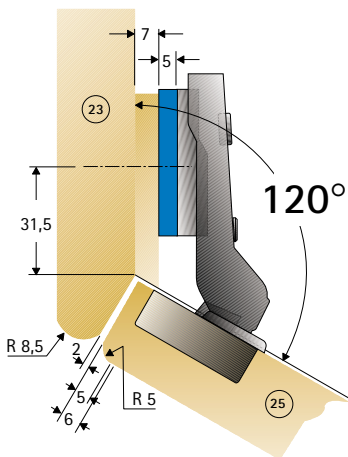

## Intermat 9936 W30

Cranking 7 mm  
Mounting plate distance 5 mm

Order no. 077 690  
Order no. 072 986

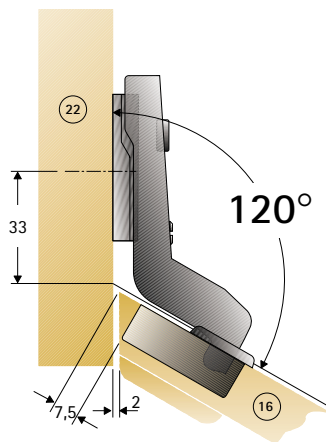

## Intermat 9936 W30

Cranking - 10 mm  
Mounting plate distance 0 mm

Order no. 073 928  
Order no. 072 983

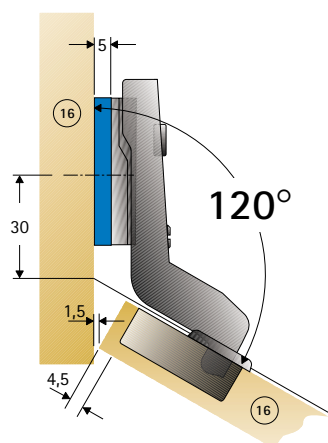

## Intermat 9936 W30

Cranking - 10 mm  
Mounting plate distance 5 mm

Bestell-Nr. 073 928  
Bestell-Nr. 072 986

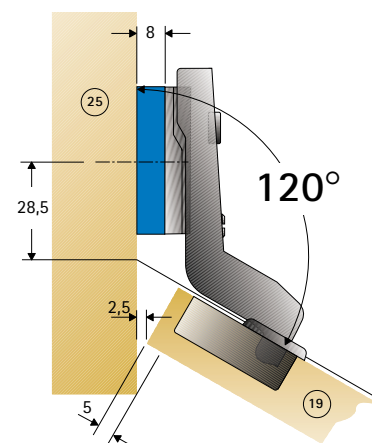

## Intermat 9936 W30

Cranking - 10 mm  
Mounting plate distance 8 mm

Order no. 073 928  
Order no. 072 987

3

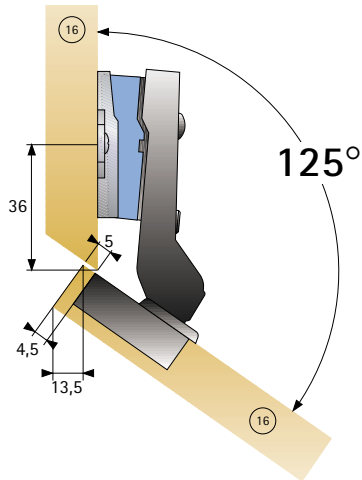

**Intermat 9936 W30**

Cranking 7 mm  
 Mounting plate distance 0 mm  
 Angle adapter 5°

Order no. 077 690  
 Order no. 072 983  
 Order no. 043 036

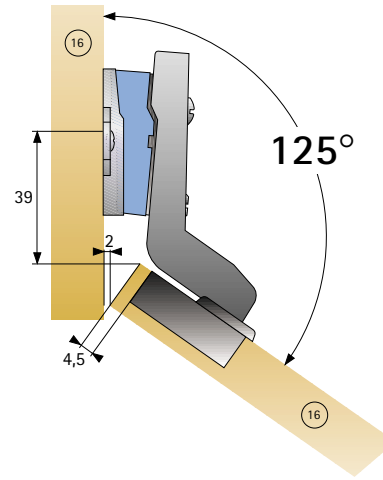

**Intermat 9936 W30**

Cranking - 10 mm  
 Mounting plate distance 0 mm  
 Angle adapter 5°

Order no. 073 928  
 Order no. 072 983  
 Order no. 043 036

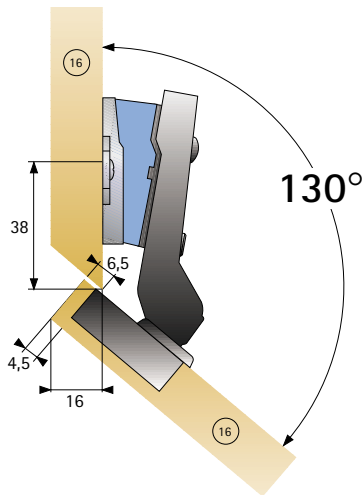

**Intermat 9936 W30**

Cranking 7 mm  
 Mounting plate distance 0 mm  
 Angle adapter 10°

Order no. 077 690  
 Order no. 072 983  
 Order no. 043 037

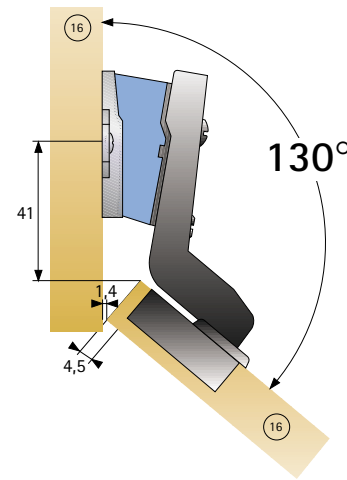

**Intermat 9936 W30**

Cranking - 10 mm  
 Mounting plate distance 1,5 mm  
 Angle adapter 10°

Order no. 073 928  
 Order no. 072 984  
 Order no. 043 037

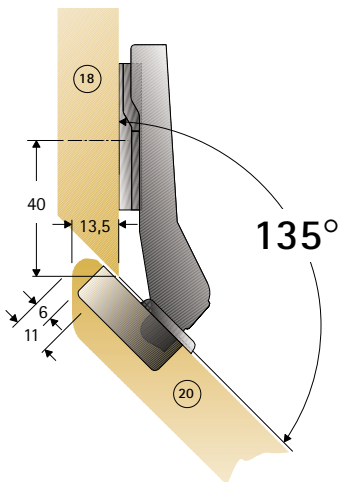

**Intermat 9936 W45**

Cranking 6 mm  
 Mounting plate distance 0 mm

Order no. 077 699  
 Order no. 072 983

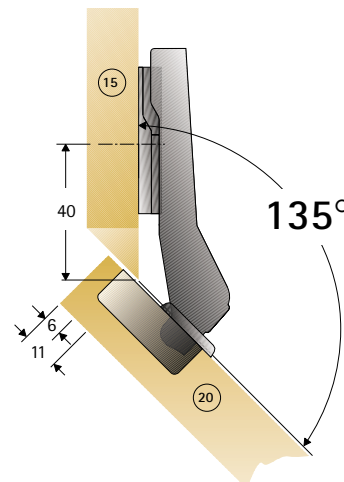

**Intermat 9936 W45**

Cranking 6 mm  
 Mounting plate distance 0 mm

Order no. 077 699  
 Order no. 072 983

# Intermat mounting solutions for cabinet face angles...

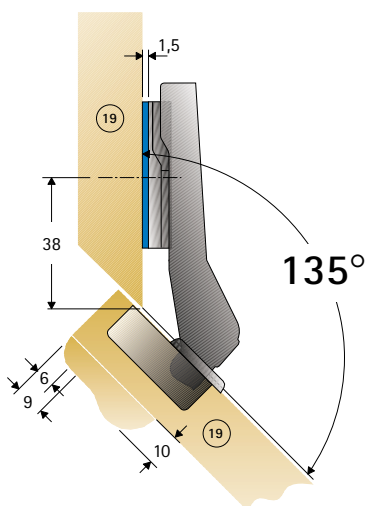

**Intermat 9936 W45**

Cranking 6 mm  
Mounting plate distance 1,5 mm

Order no. 077 699  
Order no. 072 984

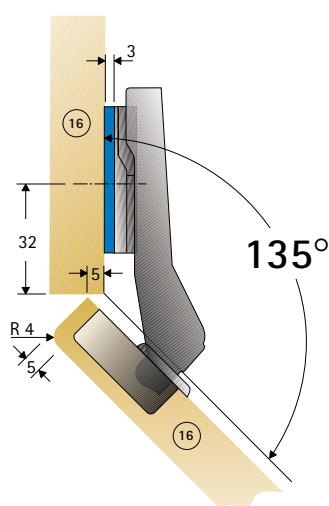

**Intermat 9936 W45**

Cranking 6 mm  
Mounting plate distance 3 mm

Order no. 077 699  
Order no. 072 985

3

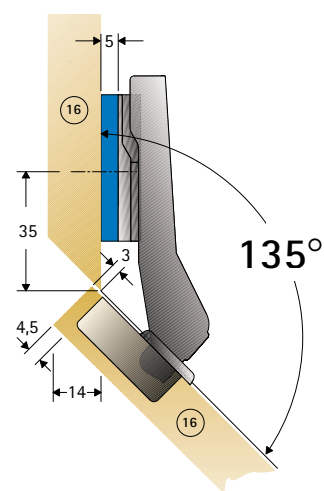

**Intermat 9936 W45**

Cranking 6 mm  
Mounting plate distance 5 mm

Order no. 077 699  
Order no. 072 986

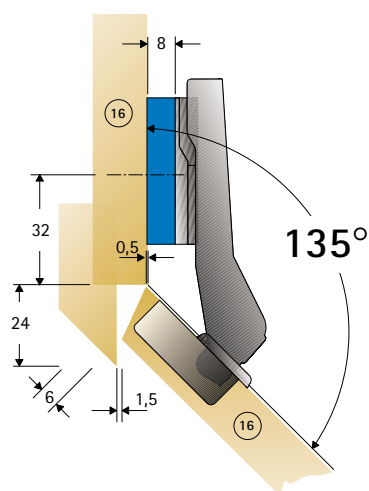

**Intermat 9936 W45**

Cranking 6 mm  
Mounting plate distance 8 mm

Order no. 077 699  
Order no. 072 987

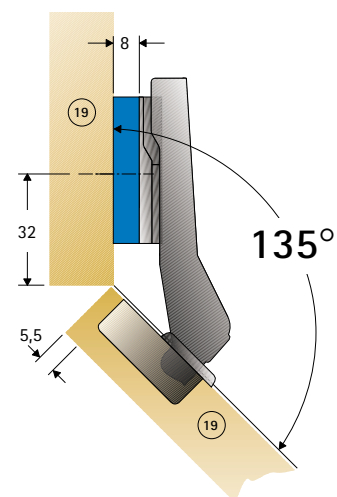

**Intermat 9936 W45**

Cranking 6 mm  
Mounting plate distance 8 mm

Order no. 077 699  
Order no. 072 987

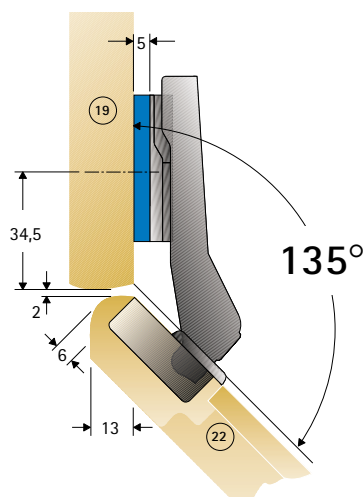

**Intermat 9936 W45**

Cranking 6 mm  
Mounting plate distance 5 mm

Order no. 077 699  
Order no. 072 986

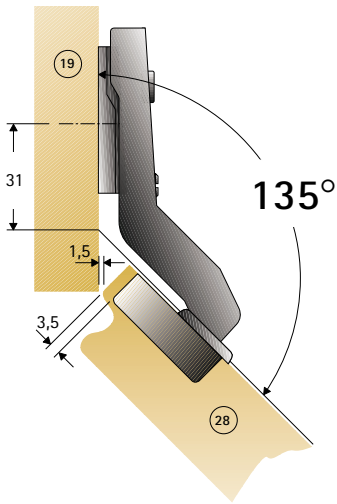

**Intermat 9936 W45**

Cranking - 17 mm

Mounting plate distance 0 mm

Order no. 073 932

Order no. 072 983

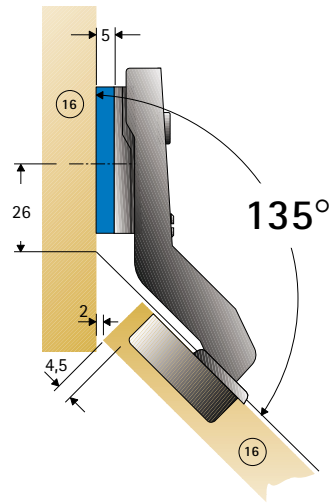

**Intermat 9936 W45**

Cranking - 17 mm

Mounting plate distance 5 mm

Order no. 073 932

Order no. 072 986

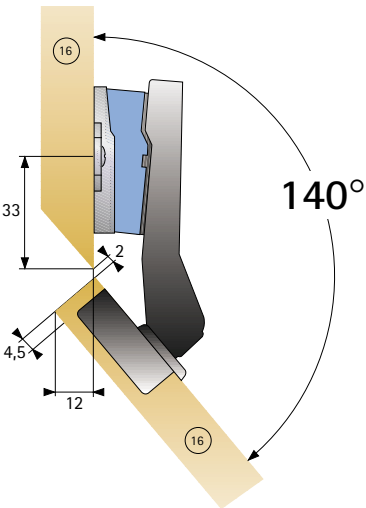

**Intermat 9936 W45**

Cranking 6 mm

Mounting plate distance 0 mm

Angle adapter 5°

Order no. 077 699

Order no. 072 983

Order no. 043 036

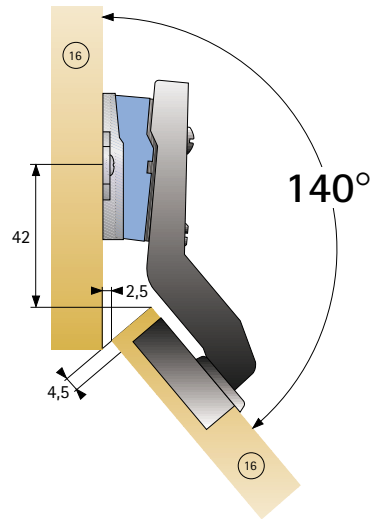

**Intermat 9936 W45**

Cranking - 17 mm

Mounting plate distance 0 mm

Angle adapter 5°

Order no. 073 932

Order no. 072 983

Order no. 043 036

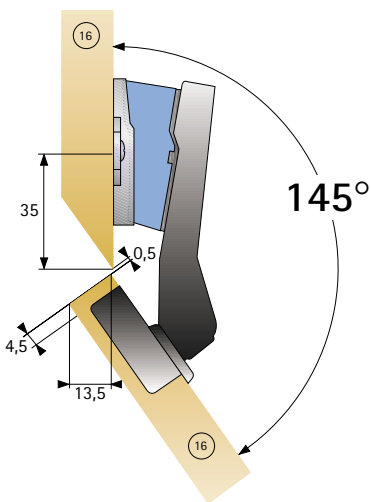

**Intermat 9936 W45**

Cranking 6 mm

Mounting plate distance 0 mm

Angle adapter 10°

Order no. 077 699

Order no. 072 983

Order no. 043 037

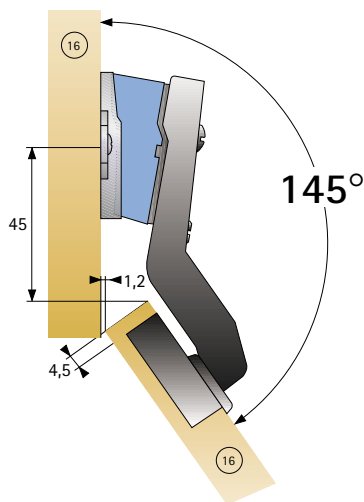

**Intermat 9936 W45**

Cranking - 17 mm

Mounting plate distance 1,5 mm

Angle adapter 10°

Order no. 073 932

Order no. 072 984

Order no. 043 037

# Intermat mounting solutions for cabinet face angles...

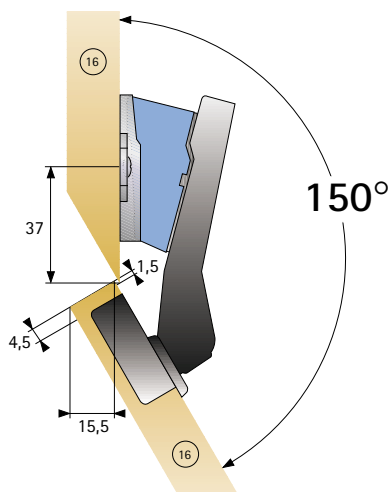

**Intermat 9936 W45**  
 Cranking 6 mm  
 Mounting plate distance 0 mm  
 Angle adapter 15°

Order no. 077 699  
 Order no. 072 983  
 Order no. 043 038

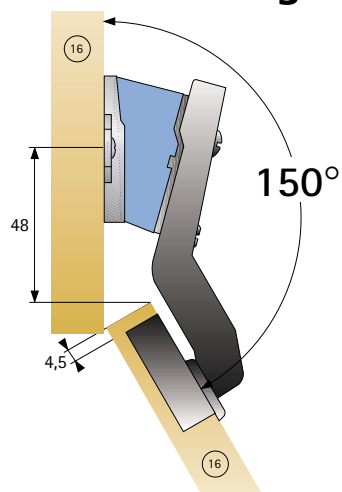

**Intermat 9936 W45**  
 Cranking - 17 mm  
 Mounting plate distance 3 mm  
 Angle adapter 15°

Order no. 073 932  
 Order no. 072 985  
 Order no. 043 038

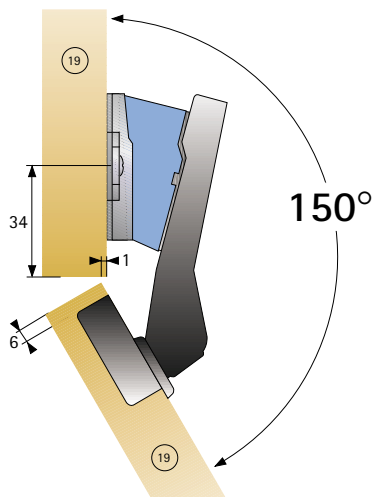

**Intermat 9936 W45**  
 Cranking 6 mm  
 Mounting plate distance 1,5 mm  
 Angle adapter 15°

Order no. 077 699  
 Order no. 072 984  
 Order no. 043 038

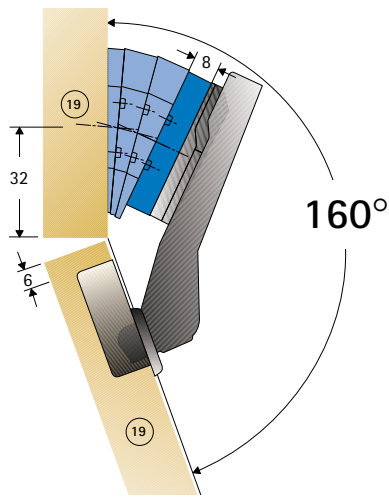

**Intermat 9936 W45**  
 Cranking 6 mm  
 Mounting plate distance 8 mm  
 2 x angle plate 10°  
 1 x angle plate 5°

Order no. 077 699  
 Order no. 072 987  
 Order no. 079 350  
 Order no. 079 349

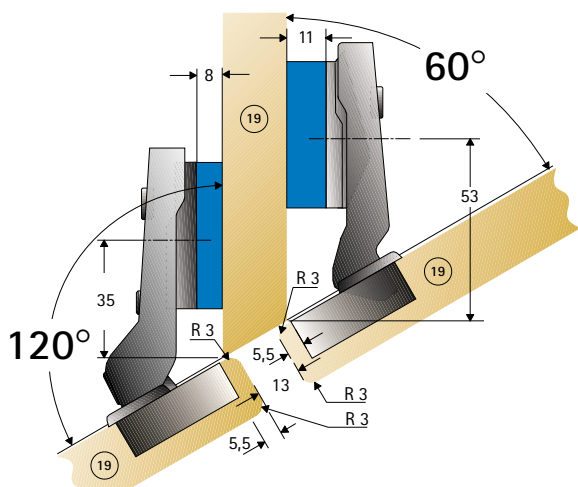

**Intermat 9936 W30**  
 Cranking 7 mm  
 Mounting plate distance 8 mm  
**Intermat 9944 W-30**  
 Cranking 12 mm  
 Mounting plate distance 11 mm

Order no. 077 690  
 Order no. 072 987  
 Order no. 073 936  
 Order no. 077 946

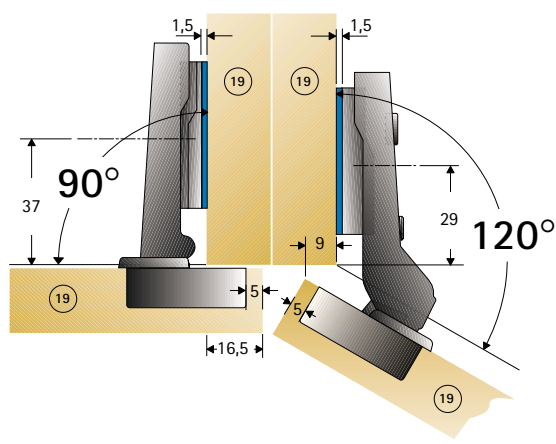

**Intermat 9943**  
 Cranking 0 mm  
 Mounting plate distance 1,5 mm  
**Intermat 9936 W30**  
 Cranking 7 mm  
 Mounting plate distance 1,5 mm

Order no. 048 049  
 Order no. 072 984  
 Order no. 077 690  
 Order no. 072 984

3

# and special variants

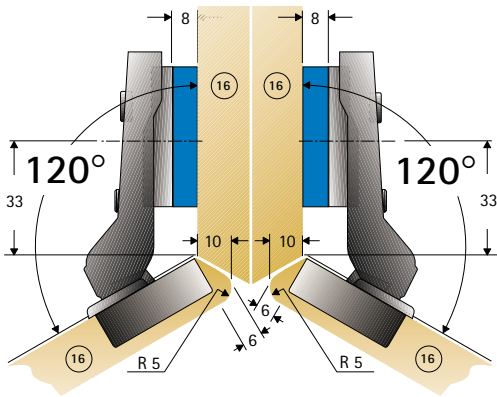

**Interimat 9936 W30**  
 Cranking 7 mm                      Order no. 077 690  
 Mounting plate distance 8 mm    Order no. 072 987

**Interimat 9936 W30**  
 Cranking 7 mm                      Order no. 077 690  
 Mounting plate distance 8 mm    Order no. 072 987

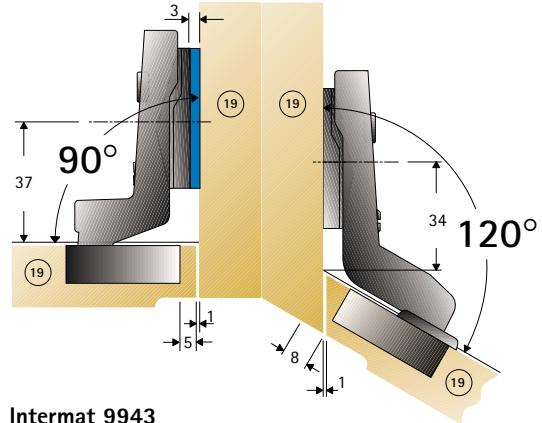

**Interimat 9943**  
 Cranking 16 mm                      Order no. 048 052  
 Mounting plate distance 3 mm    Order no. 072 985

**Interimat 9936 W30**  
 Cranking - 10 mm                      Order no. 073 928  
 Mounting plate distance 0 mm    Order no. 072 983

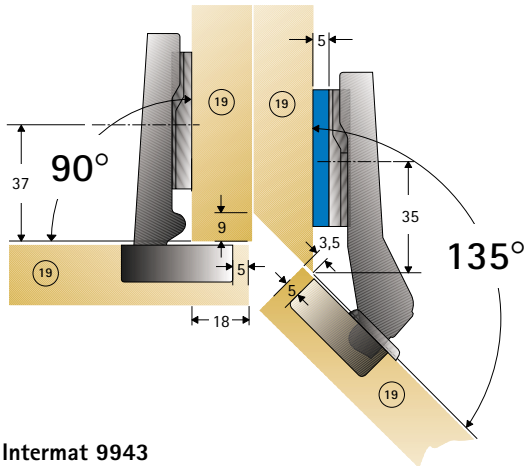

**Interimat 9943**  
 Cranking 0 mm                      Order no. 048 049  
 Mounting plate distance 0 mm    Order no. 072 983

**Interimat 9936 W45**  
 Cranking 6 mm                      Order no. 077 699  
 Mounting plate distance 5 mm    Order no. 072 986

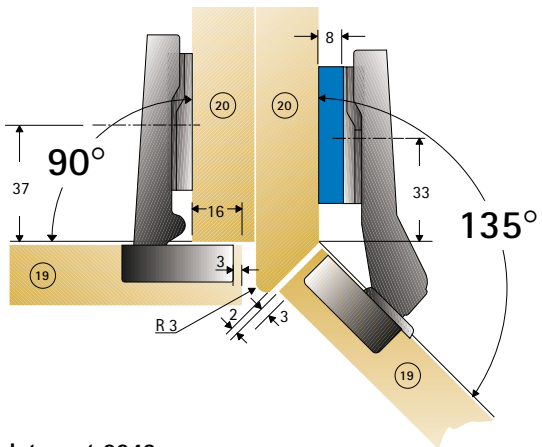

**Interimat 9943**  
 Cranking 0 mm                      Order no. 048 049  
 Mounting plate distance 0 mm    Order no. 072 983

**Interimat 9936 W45**  
 Cranking 6 mm                      Order no. 077 699  
 Mounting plate distance 8 mm    Order no. 072 987

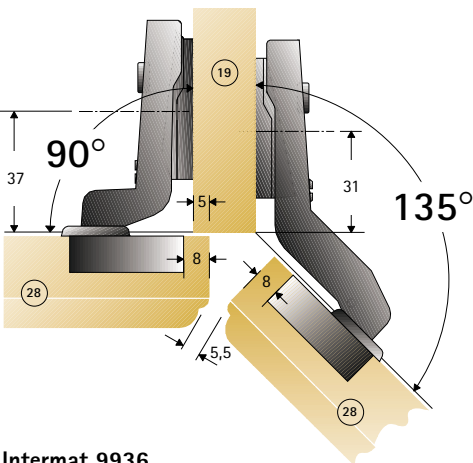

**Interimat 9936**  
 Cranking 16 mm                      Order no. 073 921  
 Mounting plate distance 0 mm    Order no. 072 983

**Interimat 9936 W45**  
 Cranking - 17 mm                      Order no. 073 932  
 Mounting plate distance 0 mm    Order no. 072 983



# Hettich Slide-on

## The Slide-on range:

|                                   |               |
|-----------------------------------|---------------|
| Technical information<br>Pages    | 3.136 - 3.137 |
| Slide-on hinge selection<br>Pages | 3.138 - 3.149 |

3



Hettich's new hinge scores points for quality and environmental awareness. Tested quality ensures full functionality for a long service life – after which the all-steel hinge can be fully recycled.

The Hettich-Direkt fixing system

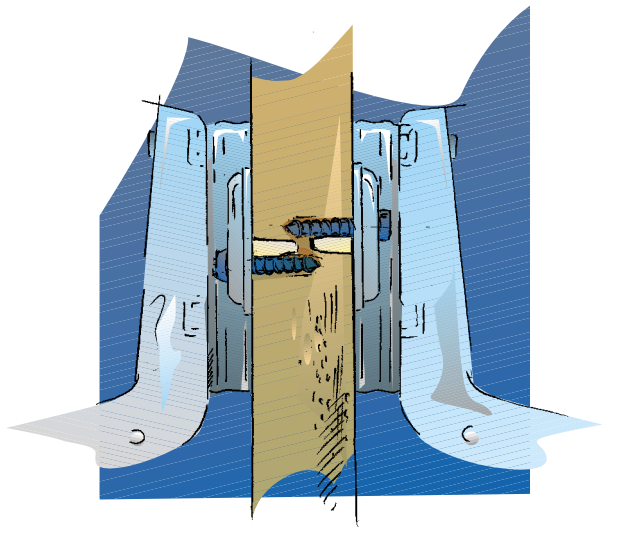
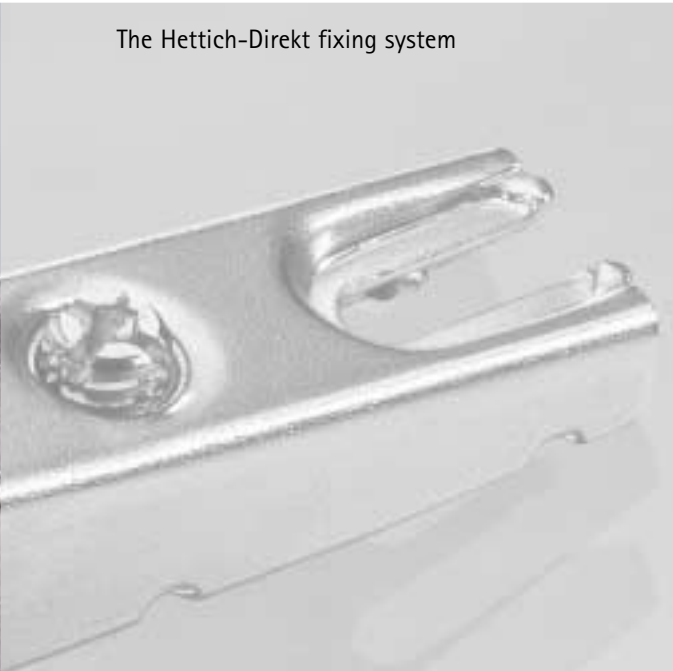

# Great hinge with clear benefits

A new Hettich hinge is making its debut. The first points to catch the eye are the compact design and the shallow cup. Then there's the tried- and trusted slide-on technology - the overlay can be adjusted without loosening any screws.

The hinge is available with different cranking for inset and offset doors and for mounting on centre panels.

The special Hettich-Direkt fixing system, with asymmetrically positioned screws, assures high tear-out values on centre panels from 15 mm thick. Assembly is made much easier by dowels integrated on the mounting plate that hold the system in place while the screws are being tightened. With Hettich-Direkt, hinge heights can still be adjusted over the full range.



# Slide-on Concealed hinges

## Technical information

### Distance

Mounting plates are available in various thicknesses with an effective height characterized by the value of the distance.

Starting point for calculating the required distance is the selected hinge with defined door overlay.

Using planned cup distance and door thickness, first read the required reveal value from the table. If this value is too large for the desired overlay, it can be reduced either by increasing the cup distance C or by chamfering the door edge.

Once the door reveal and cup distance C have been defined, the mounting plate distance can be derived from the table.

If the distance value deviates from the actual mounting plate distance shown in the catalogue, the difference can be compensated by turning the overlay adjustment screw.

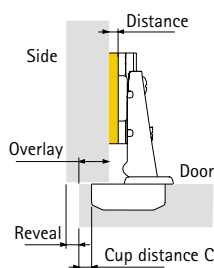

Example: Slide-on 2333 - 0 mm cranking

Fixed sizes

Overlay 15 mm

Cup distance 4,5 mm

Distance of 4 mm

The table shows a

Select a mounting plate with a distance of 3 mm and reduce the overlay by 1 mm by turning the overlay adjustment screw.

| Cup distance<br>C mm | Door overlay mm |     |     |     |     |     |     |     |     |     |
|----------------------|-----------------|-----|-----|-----|-----|-----|-----|-----|-----|-----|
|                      | 10              | 11  | 12  | 13  | 14  | 15  | 16  | 17  | 18  | 19  |
|                      | Distance D mm   |     |     |     |     |     |     |     |     |     |
| 3                    | 7,5             | 6,5 | 5,5 | 4,5 | 3,5 | 2,5 | 1,5 |     |     |     |
| 4                    | 8,5             | 7,5 | 6,5 | 5,5 | 4,5 | 3,5 | 2,5 | 1,5 |     |     |
| 4,5                  | 9,0             | 8,0 | 7,0 | 6,0 | 5,0 | 4,0 | 3,0 | 2,0 | 0,5 |     |
| 5                    | 9,5             | 8,5 | 7,5 | 6,5 | 5,5 | 4,5 | 3,5 | 2,5 | 1,5 |     |
| 6                    | 10,5            | 9,5 | 8,5 | 7,5 | 6,5 | 5,5 | 4,5 | 3,5 | 2,5 | 1,5 |

Overlay adjustment - 3 mm, + 0,5 mm

### Door adjustment

Hettich Slide-on hinges offer all the benefits of three-dimensional adjustability (vertical, lateral and depth) to get doors perfectly aligned.

#### Overlay adjustment

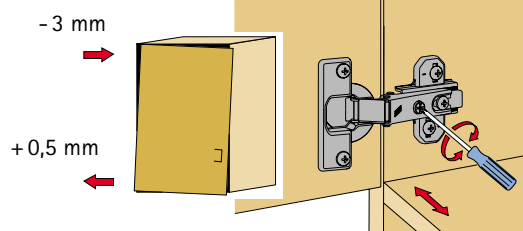

Turn screw **clockwise**: door overlay **decreases** (-)

Turn screw **anticlockwise**: door overlay **increases** (+)

#### Height adjustment

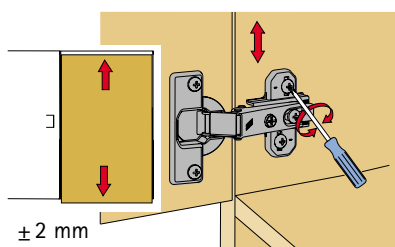

#### Depth adjustment

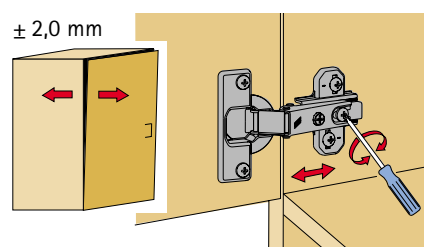

Loosen the mounting plate screws and adjust the door height. Then retighten the screws.

Loosen the screw and adjust the gap between door and cabinet. Then retighten the screw.



### Hettich-Direkt

The **Hettich-Direkt** mounting plate is ideal for **centre panels from 15 mm thickness**.

The **premounted locating pegs** are simply inserted into the **ø 5 mm hole line**. Even before being screwed into position, the mounting plate sits firmly into the drilling. This simplifies assembly not only of the centre panel, but also in the cabinet area.

The special screws, which are also pre-mounted in the mounting plate, are arranged asymmetrically so that they do not foul one another when mounted in the centre upright area.

This patented solution makes it feasible to use longer screws with better tear-out values which provide improved safety in daily use.

The entire height can be adjusted via the oval mounting holes!

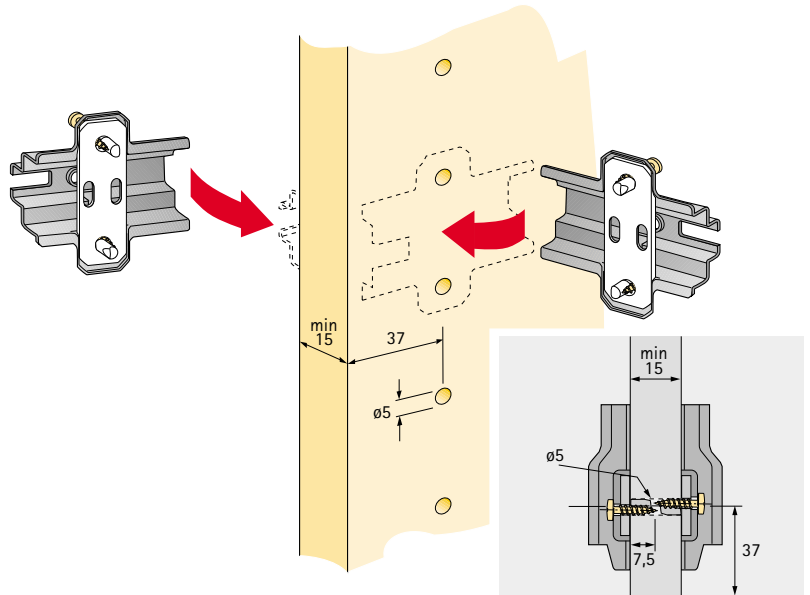

3

### Assembly

Slide the side arm of the hinge under the premounted screw on the mounting plate (1) and push home.

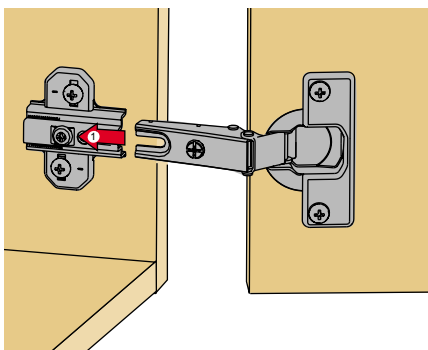

The screw is now tightened corresponding to the required depth position of the door (2).

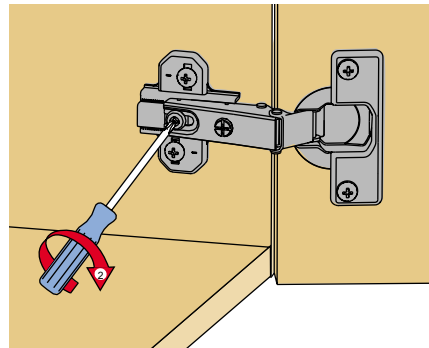

### Disassembly

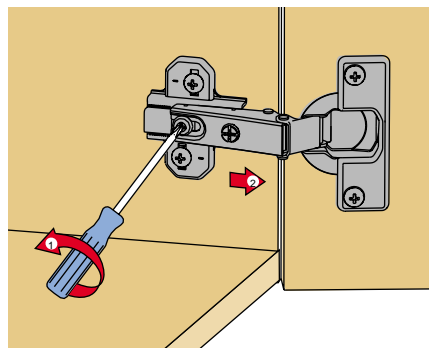

Disassemble the hinge in reverse order.

# Slide-on 2333

## Concealed hinge

### Opening angle 95°

For door thicknesses from 14 mm

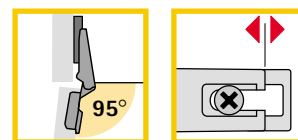

#### Concealed hinge, slide-on attachment, integrated overlay and depth adjustment

Opening angle 95°, cup diameter 35 mm.

Small hole depth for door thickness 14 mm or larger.

Slide-on-hinges are attached by sliding them onto the mounting plate.

Depth adjustment +2 mm/-2 mm.

Height adjustment via mounting plate +2 mm/-2 mm, see page 3.148.

Cup fixing screw  $\varnothing$  3,5 x 13 mm nickel-plated, for cup T42

Order no. 048 296, PU 200

#### Cup version

**Cup T42**  
Screw-on  
Nickel-plated steel



**Cup T43**  
Press-in  
Nickel-plated steel

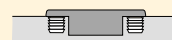

#### Hinge version

#### Mounting option

#### Article/order number

Cranking 0 mm



Full overlay

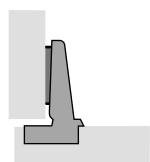

**Hettich Slide-on 2333**  
● self-closing

Packaging unit 50 pcs

● 2333-T42  
**010 189**

● 2333-T43  
**010 192**

Cranking 9,5 mm



Half overlay

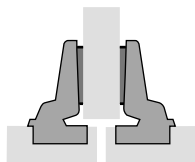

**Hettich Slide-on 2333**  
● self-closing

Packaging unit 50 pcs

● 2333-T42  
**010 190**

● 2333-T43  
**010 193**

Cranking 16 mm



Inset

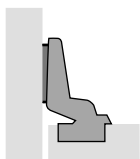

**Hettich Slide-on 2333**  
● self-closing

Packaging unit 50 pcs

● 2333-T42  
**010 191**

● 2333-T43  
**010 194**

## Specification

Hettich Slide-on 2333

Concealed hinge, slide-on attachment

Integrated overlay and depth adjustment

for door thickness from 14 mm

opening angle 95°

| Cup distance<br>C mm  | Door thickness mm |     |     |     |     |     |     |     |     |     |
|---|-------------------|-----|-----|-----|-----|-----|-----|-----|-----|-----|
|   | 16                | 17  | 18  | 19  | 20  | 21  | 22  | 23  | 24  | 25  |
| <b>Minimum reveal per door – allow for distance calculation</b> |                   |     |     |     |     |     |     |     |     |     |
| Values in table apply to doors with 0 mm radius                 |                   |     |     |     |     |     |     |     |     |     |
| 3   | 0,6               | 0,8 | 1,1 | 1,5 | 1,9 | 2,4 | 3,1 | 4,0 | 4,8 | 5,8 |
| 4   | 0,5               | 0,7 | 1,0 | 1,4 | 1,8 | 2,3 | 2,8 | 3,5 | 4,3 | 5,3 |
| 4,5   | 0,4               | 0,5 | 0,9 | 1,4 | 1,8 | 2,3 | 2,8 | 3,4 | 4,1 | 5,0 |
| 5   | 0,2               | 0,4 | 0,8 | 1,3 | 1,7 | 2,2 | 2,7 | 3,3 | 4,0 | 4,8 |
| 6   | 0                 | 0,3 | 0,7 | 1,3 | 1,6 | 2,0 | 2,5 | 3,2 | 3,8 | 4,5 |

The minimum reveal is reduced for doors with radii: 1 mm radius: table entry – 0,4 mm  
3 mm radius: table entry – 1,2 mm

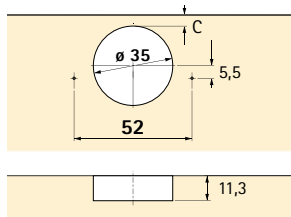

T42 hole dimensions

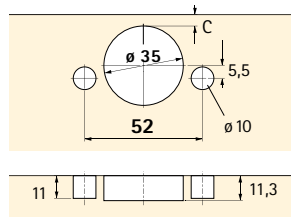

T43 hole dimensions

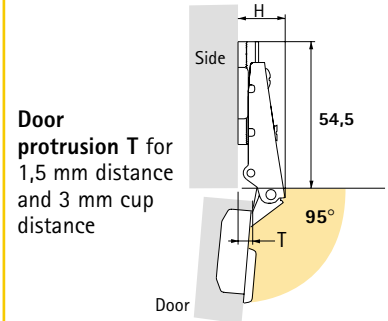

Door protrusion T for 1,5 mm distance and 3 mm cup distance

| Cranking mm | H mm | T mm |
|-------------|------|------|
| 0           | 19   | 6    |
| 9,5         | 28,5 | 15,5 |
| 16          | 35   | 22   |

3

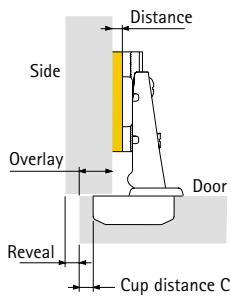

| Cup distance<br>C mm | Overlay mm |     |     |     |     |     |     |     |     |     |
|----------------------|------------|-----|-----|-----|-----|-----|-----|-----|-----|-----|
|                      | 10         | 11  | 12  | 13  | 14  | 15  | 16  | 17  | 18  | 19  |
| <b>Distance D mm</b> |            |     |     |     |     |     |     |     |     |     |
| 3                    | 7,5        | 6,5 | 5,5 | 4,5 | 3,5 | 2,5 | 1,5 |     |     |     |
| 4                    | 8,5        | 7,5 | 6,5 | 5,5 | 4,5 | 3,5 | 2,5 | 1,5 |     |     |
| 4,5                  | 9,0        | 8,0 | 7,0 | 6,0 | 5,0 | 4,0 | 3,0 | 2,0 | 0,5 |     |
| 5                    | 9,5        | 8,5 | 7,5 | 6,5 | 5,5 | 4,5 | 3,5 | 2,5 | 1,5 |     |
| 6                    | 10,5       | 9,5 | 8,5 | 7,5 | 6,5 | 5,5 | 4,5 | 3,5 | 2,5 | 1,5 |

\* Overlay adjustment – 3 mm, + 0,5 mm

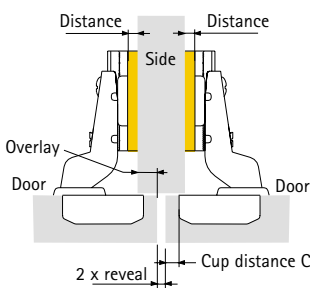

| Cup distance<br>C mm | Overlay mm |      |     |     |     |     |     |     |     |     |    |
|----------------------|------------|------|-----|-----|-----|-----|-----|-----|-----|-----|----|
|                      | 0          | 1    | 2   | 3   | 4   | 5   | 6   | 7   | 8   | 9   | 10 |
| <b>Distance D mm</b> |            |      |     |     |     |     |     |     |     |     |    |
| 3                    | 8,0        | 7,0  | 6,0 | 5,0 | 4,0 | 3,0 | 2,0 | 1,0 | 0   |     |    |
| 4                    | 9,0        | 8,0  | 7,0 | 6,0 | 5,0 | 4,0 | 3,0 | 2,0 | 1,0 | 0   |    |
| 4,5                  | 9,5        | 8,5  | 7,5 | 6,5 | 5,5 | 4,5 | 3,5 | 2,5 | 1,5 | 0,5 | 0  |
| 5                    | 10,0       | 9,0  | 8,0 | 7,0 | 6,0 | 5,0 | 4,0 | 3,0 | 2,0 | 1,0 | 0  |
| 6                    | 11,0       | 10,0 | 9,0 | 8,0 | 7,0 | 6,0 | 5,0 | 4,0 | 3,0 | 2,0 | 1  |

\* Overlay adjustment – 3 mm, + 0,5 mm

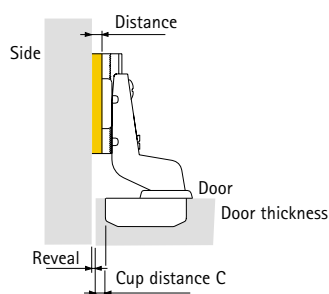

| Cup distance<br>C mm | Door thickness mm |     |     |     |     |     |     |     |     |     |
|----------------------|-------------------|-----|-----|-----|-----|-----|-----|-----|-----|-----|
|                      | 16                | 17  | 18  | 19  | 20  | 21  | 22  | 23  | 24  | 25  |
| <b>Distance D mm</b> |                   |     |     |     |     |     |     |     |     |     |
| 3                    | 2,1               | 2,3 | 2,6 | 3,0 | 3,4 | 3,9 | 4,6 | 5,5 | 6,3 | 7,3 |
| 4                    | 3,0               | 3,2 | 3,5 | 3,9 | 4,3 | 4,8 | 5,3 | 6,0 | 6,8 | 7,8 |
| 4,5                  | 3,4               | 3,5 | 3,9 | 4,4 | 4,8 | 5,3 | 5,8 | 6,4 | 7,1 | 8,0 |
| 5                    | 3,7               | 3,9 | 4,3 | 4,8 | 5,2 | 5,7 | 6,2 | 6,8 | 7,5 | 8,3 |
| 6                    | 4,5               | 4,8 | 5,2 | 5,8 | 6,1 | 6,5 | 7,0 | 7,7 | 8,3 | 9,0 |

\*Reveal adjustment + 3 mm, – 0,5 mm

# Slide-on 2356

## Concealed hinge

### Opening angle 165° – 120°

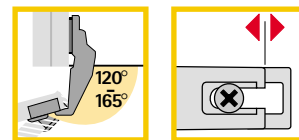

#### Concealed wide-angle hinge, slide-on attachment, integrated overlay and depth adjustment.

Opening angle 165° – the opening angle can be variably adjusted up to 120° with the adjustment screw (Order-no. 079791)\*.

Cup diameter 35 mm.

The wide-angle hinge results in optimal reveal (hairline reveal).

Negative door protrusion.

Slide-on 2356 hinges are attached by sliding them onto the mounting plate.

Depth adjustment +2 mm/-2 mm.

Height adjustment via mounting plate +2 mm/-2 mm, see page 3.148.

Cup fixing screw  $\varnothing$  3,5 x 13 mm nickel-plated, for cup T 42

Order no. 048 296, PU 200

#### Cup version

##### Cup T 42

Screw-on  
Nickel-plated steel

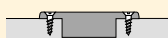

##### Cup T 43

Press-in  
Nickel-plated steel

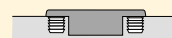

#### Hinge version

#### Mounting option

#### Article/order number

Cranking 0 mm

Full overlay

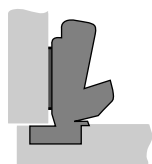

#### Hettich Slide-on 2356

- self-closing

Packaging unit 50 pcs

● 2356-T42

013 090

● 2356-T43

013 092

Cranking 9,5 mm

Half overlay

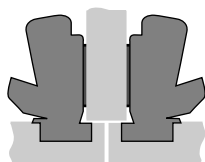

#### Hettich Slide-on 2356

- self-closing

Packaging unit 50 pcs

● 2356-T42

013 091

● 2356-T43

013 093

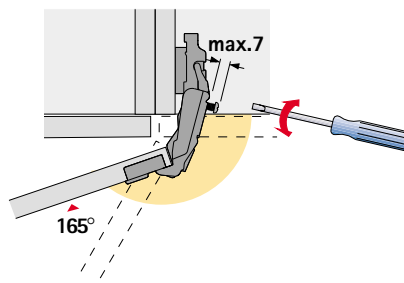
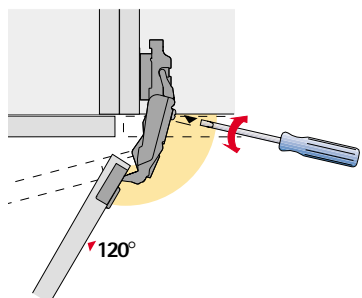

\* Opening angle 165° – stepless adjustment of the opening angle up to 120° via the adjustment screw M5x14 mm.

Adjustment screw M5 x14 mm

| Order no. | PU     |
|-----------|--------|
| 079 791   | 50 pcs |

## Specification

Hettich Slide-on 2356

Concealed hinge, slide-on attachment

Integrated overlay and depth adjustment

Hairline reveal for up to 19 mm doors, negative door protrusion

Stepless adjustment of opening angle 165° – 120°

| Cup distance<br>C mm | Door thickness mm |    |    |    |
|----------------------|-------------------|----|----|----|
|                      | 16                | 17 | 18 | 19 |

**Minimum reveal per door** – allow for distance calculation  
Values in table apply to doors with 0 mm radius

|     |   |   |   |   |
|-----|---|---|---|---|
| 3   | 0 | 0 | 0 | 0 |
| 4   | 0 | 0 | 0 | 0 |
| 4,5 | 0 | 0 | 0 | 0 |
| 5   | 0 | 0 | 0 | 0 |
| 6   | 0 | 0 | 0 | 0 |

The minimum reveal for doors up to 19 mm thick is 0 mm.  
A trial assembly is recommended for doors thicker than 19 mm (max. door thickness 25 mm).

The minimum reveal is reduced for doors with radii: 1 mm radius: table entry – 0,4 mm  
3 mm radius: table entry – 1,2 mm

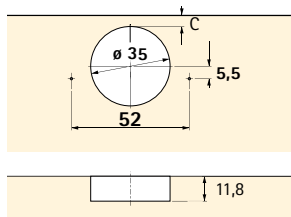

T42 hole dimensions

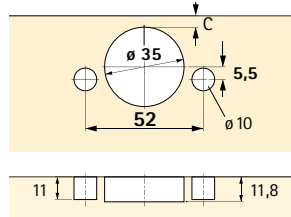

T43 hole dimensions

No door protrusion T for 0 mm distance and 3 mm cup distance, unrestricted runner movement

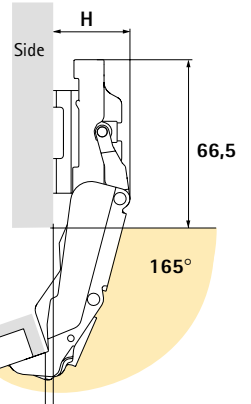

| Cranking mm | H mm | T mm |
|-------------|------|------|
| 0           | 40,5 | -1,4 |
| 9,5         | 51   | 8,1  |

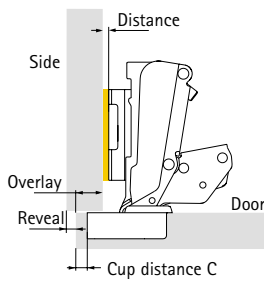

| Cup distance<br>C mm | Overlay mm |     |     |     |     |     |     |     |     |     |
|----------------------|------------|-----|-----|-----|-----|-----|-----|-----|-----|-----|
|                      | 10         | 11  | 12  | 13  | 14  | 15  | 16  | 17  | 18  | 19  |
| 3                    | 7,5        | 6,5 | 5,5 | 4,5 | 3,5 | 2,5 | 1,5 | 0,5 |     |     |
| 4                    | 8,5        | 7,5 | 6,5 | 5,5 | 4,5 | 3,5 | 2,5 | 1,5 | 0,5 |     |
| 4,5                  | 9,0        | 8,0 | 7,0 | 6,0 | 5,0 | 4,0 | 3,0 | 2,0 | 1,0 |     |
| 5                    | 9,5        | 8,5 | 7,5 | 6,5 | 5,5 | 4,5 | 3,5 | 2,5 | 1,5 | 0,5 |
| 6                    | 10,5       | 9,5 | 8,5 | 7,5 | 6,5 | 5,5 | 4,5 | 3,5 | 2,5 | 1,5 |

\* Overlay adjustment – 3 mm, + 0,5 mm

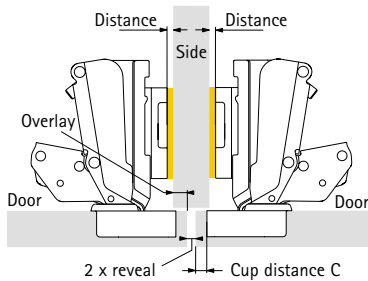

| Cup distance<br>C mm | Overlay mm |      |     |     |     |     |     |     |     |     |
|----------------------|------------|------|-----|-----|-----|-----|-----|-----|-----|-----|
|                      | 0          | 1    | 2   | 3   | 4   | 5   | 6   | 7   | 8   | 9   |
| 3                    | 8,0        | 7,0  | 6,0 | 5,0 | 4,0 | 3,0 | 2,0 | 1,0 |     |     |
| 4                    | 9,0        | 8,0  | 7,0 | 6,0 | 5,0 | 4,0 | 3,0 | 2,0 | 1,0 |     |
| 4,5                  | 9,5        | 8,5  | 7,5 | 6,5 | 5,5 | 4,5 | 3,5 | 2,5 | 1,5 | 0,5 |
| 5                    | 10,0       | 9,0  | 8,0 | 7,0 | 6,0 | 5,0 | 4,0 | 3,0 | 2,0 | 1,0 |
| 6                    | 11,0       | 10,0 | 9,0 | 8,0 | 7,0 | 6,0 | 5,0 | 4,0 | 3,0 | 2,0 |

\* Overlay adjustment – 3 mm, + 0,5 mm

# Slide-on 2336 W30 Concealed hinge for corner cabinets Opening angle 95°

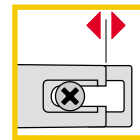
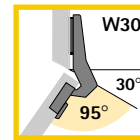

## Concealed hinge, slide-on attachment, integrated door overlay and depth adjustment.

Opening angle with 95°, cup diameter 35 mm.

For corner cupboards and cabinets with 30° face angle.

Slide-on 2336 W30 hinges are attached by sliding them onto the mounting plate.

Depth adjustment +2 mm/-2 mm.

Height adjustment via mounting plate +2 mm/-2 mm, see page 3.148.

Cup fixing screw  $\varnothing$  3,5 x 13 mm nickel-plated, for cup T 42

Order no. 048 296, PU 200

### Cup version

#### Cup T 42

Screw-on  
Nickel-plated steel

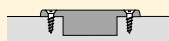

#### Cup T 43

Press-in  
Nickel-plated steel

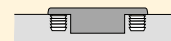

### Hinge version



Cranking 8 mm

### Mounting option

Full overlay

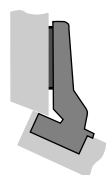

### Article/order number

#### Hettich Slide-on 2336 W30

● self-closing

Packaging unit 50 pcs

● 2336 W30-T42

013 094

● 2336 W30-T43

013 095

### Mounting example Slide-on 2336 W30 Full overlay

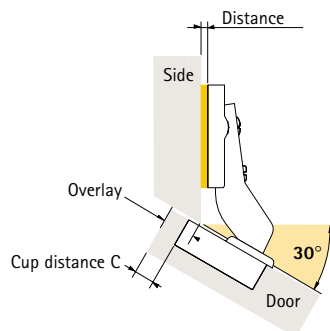

## Specification

Hettich Slide-on 2336 W30

Concealed hinge, slide-on attachment

Integrated overlay and depth adjustment

for 30° face angle applications

opening angle 95°

| Cup distance<br>C mm  | Door thickness mm |     |     |     |     |     |     |     |     |     |     |     |     |     |     |     |     |
|---|-------------------|-----|-----|-----|-----|-----|-----|-----|-----|-----|-----|-----|-----|-----|-----|-----|-----|
|   | 16                | 17  | 18  | 19  | 20  | 21  | 22  | 23  | 24  | 25  | 26  | 27  | 28  | 29  | 30  | 31  | 32  |
| <b>Minimum reveal per door – allow for distance calculation</b> |                   |     |     |     |     |     |     |     |     |     |     |     |     |     |     |     |     |
| Values in table apply to doors with 0 mm radius                 |                   |     |     |     |     |     |     |     |     |     |     |     |     |     |     |     |     |
| 3   | 0,4               | 0,6 | 0,8 | 1,0 | 1,2 | 1,5 | 1,8 | 2,1 | 2,5 | 2,9 | 3,4 | 4,0 | 4,9 | 5,7 | 6,6 | 7,5 | 8,4 |
| 4   | 0,4               | 0,6 | 0,8 | 1,0 | 1,2 | 1,5 | 1,8 | 2,1 | 2,5 | 2,8 | 3,3 | 3,8 | 4,5 | 5,3 | 6,1 | 7,0 | 7,9 |
| 4,5   | 0,4               | 0,6 | 0,8 | 1,0 | 1,2 | 1,5 | 1,8 | 2,1 | 2,5 | 2,8 | 3,3 | 3,7 | 4,3 | 5,1 | 5,9 | 6,8 | 7,7 |
| 5   | 0,4               | 0,6 | 0,8 | 1,0 | 1,2 | 1,4 | 1,7 | 2,0 | 2,4 | 2,7 | 3,2 | 3,6 | 4,2 | 4,9 | 5,7 | 6,5 | 7,4 |
| 6   | 0,4               | 0,6 | 0,8 | 1,0 | 1,2 | 1,4 | 1,7 | 2,0 | 2,3 | 2,6 | 3,1 | 3,5 | 4,0 | 4,6 | 5,3 | 6,1 | 6,9 |
| 7   | 0,4               | 0,5 | 0,7 | 0,9 | 1,1 | 1,3 | 1,6 | 1,9 | 2,2 | 2,6 | 3,0 | 3,4 | 3,9 | 4,4 | 5,0 | 5,7 | 6,5 |
| 8   | 0,4               | 0,5 | 0,7 | 0,9 | 1,1 | 1,3 | 1,6 | 1,8 | 2,1 | 2,5 | 2,9 | 3,3 | 3,7 | 4,2 | 4,8 | 5,4 | 6,1 |

The minimum reveal is reduced for doors with radii: 1 mm radius: table entry – 0,4 mm  
3 mm radius: table entry – 1,2 mm

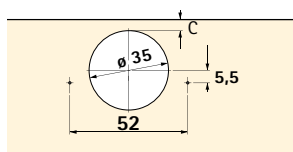

T42 hole dimensions

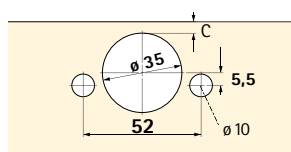

T43 hole dimensions

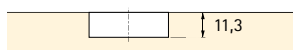

### Note:

Drawings on this page are to full scale and show the hinges plus mounting plate distances. By drawing in the required cup distance C (3–8 mm), the door overlay can be measured directly from the applicable distance line.

The distance from the **cabinet front edge to X** on the selected distance line is also equal to the hole line distance from the cabinet front edge.

### Full overlay

\* Overlay adjustment +0,5 mm / –3 mm

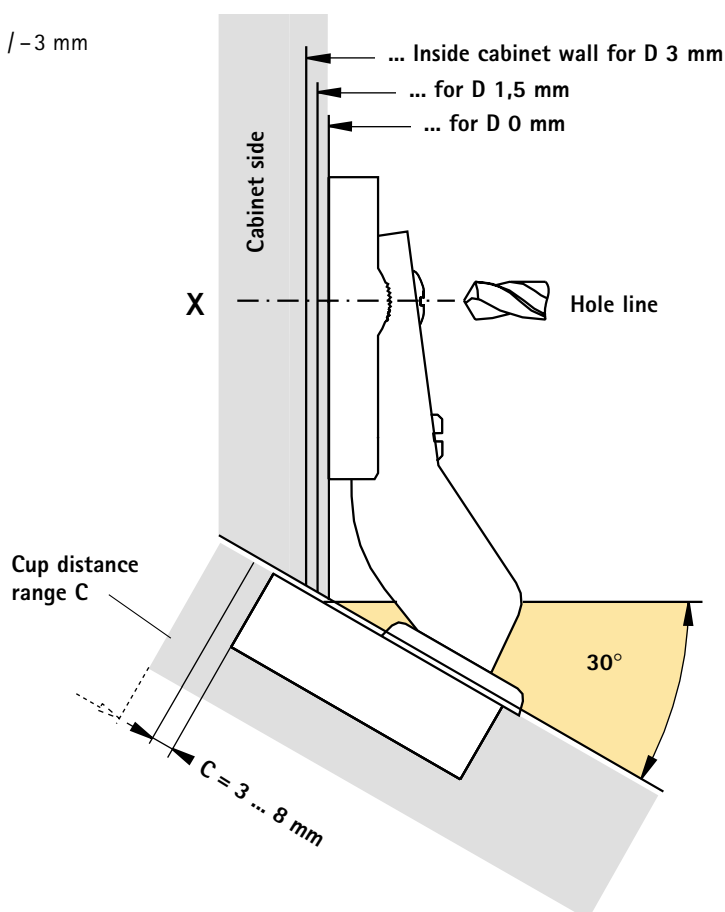

Scale 1:1

# Slide-on 2336 W45 Concealed hinge for corner cabinets Opening angle 95°

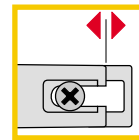
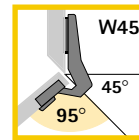

## Concealed hinge, slide-on attachment, integrated door overlay and depth adjustment.

Opening angle with 95°, cup diameter 35 mm.

For corner cupboards and cabinets with 45° face angle.

Slide-on 2336 W45 hinges are attached by sliding them onto the mounting plate.

Depth adjustment +2 mm/-2 mm.

Height adjustment via mounting plate +2 mm/-2 mm, see page 3.148.

Cup fixing screw  $\varnothing$  3,5 x 13 mm nickel-plated, for cup T 42

Order no. 048 296, PU 200

### Cup version

#### Cup T 42

Screw-on  
Nickel-plated steel

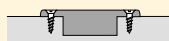

#### Cup T 43

Press-in  
Nickel-plated steel

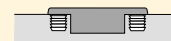

### Hinge version



### Mounting option

Full overlay

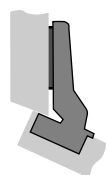

### Article/order number

#### Hettich Slide-on 2336 W45

- self-closing

Packaging unit 50 pcs

- 2336 W45-T42

013 096

- 2336 W45-T43

013 100

### Mounting example Slide-on 2336 W45 Full overlay

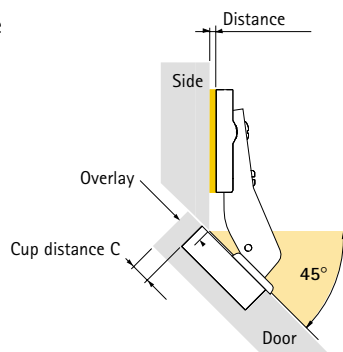

## Specification

Hettich Slide-on 2336 W45

Concealed hinge, slide-on attachment

Integrated overlay and depth adjustment

for 45° face angle applications

opening angle 95°

| Cup distance<br>C mm  | Door thickness mm |     |     |     |     |     |     |     |     |     |     |     |     |     |     |     |     |
|---|-------------------|-----|-----|-----|-----|-----|-----|-----|-----|-----|-----|-----|-----|-----|-----|-----|-----|
|   | 16                | 17  | 18  | 19  | 20  | 21  | 22  | 23  | 24  | 25  | 26  | 27  | 28  | 29  | 30  | 31  | 32  |
| <b>Minimum reveal per door – allow for distance calculation</b> |                   |     |     |     |     |     |     |     |     |     |     |     |     |     |     |     |     |
| Values in table apply to doors with 0 mm radius                 |                   |     |     |     |     |     |     |     |     |     |     |     |     |     |     |     |     |
| 3   | 0,4               | 0,6 | 0,8 | 1,0 | 1,2 | 1,5 | 1,8 | 2,1 | 2,5 | 2,9 | 3,4 | 4,0 | 4,9 | 5,7 | 6,6 | 7,5 | 8,4 |
| 4   | 0,4               | 0,6 | 0,8 | 1,0 | 1,2 | 1,5 | 1,8 | 2,1 | 2,5 | 2,8 | 3,3 | 3,8 | 4,5 | 5,3 | 6,1 | 7,0 | 7,9 |
| 4,5   | 0,4               | 0,6 | 0,8 | 1,0 | 1,2 | 1,5 | 1,8 | 2,1 | 2,5 | 2,8 | 3,3 | 3,7 | 4,3 | 5,1 | 5,9 | 6,8 | 7,7 |
| 5   | 0,4               | 0,6 | 0,8 | 1,0 | 1,2 | 1,4 | 1,7 | 2,0 | 2,4 | 2,7 | 3,2 | 3,6 | 4,2 | 4,9 | 5,7 | 6,5 | 7,4 |
| 6   | 0,4               | 0,6 | 0,8 | 1,0 | 1,2 | 1,4 | 1,7 | 2,0 | 2,3 | 2,6 | 3,1 | 3,5 | 4,0 | 4,6 | 5,3 | 6,1 | 6,9 |
| 7   | 0,4               | 0,5 | 0,7 | 0,9 | 1,1 | 1,3 | 1,6 | 1,9 | 2,2 | 2,6 | 3,0 | 3,4 | 3,9 | 4,4 | 5,0 | 5,7 | 6,5 |
| 8   | 0,4               | 0,5 | 0,7 | 0,9 | 1,1 | 1,3 | 1,6 | 1,8 | 2,1 | 2,5 | 2,9 | 3,3 | 3,7 | 4,2 | 4,8 | 5,4 | 6,1 |

The minimum reveal is reduced for doors with radii: 1 mm radius: table entry – 0,4 mm  
3 mm radius: table entry – 1,2 mm

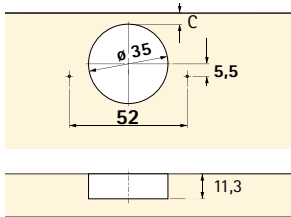

T42 hole dimensions

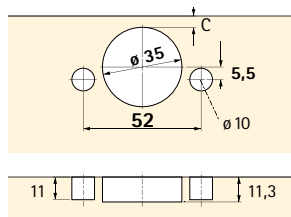

T43 hole dimensions

### Note:

Drawings on this page are to full scale and show the hinges plus mounting plate distances. By drawing in the required cup distance C (3–8 mm), the door overlay can be measured directly from the applicable distance line.

The distance from the **cabinet front edge to X** on the selected distance line is also equal to the hole line distance from the cabinet front edge.

### Full overlay

\* Overlay adjustment +0,5 mm / –3 mm

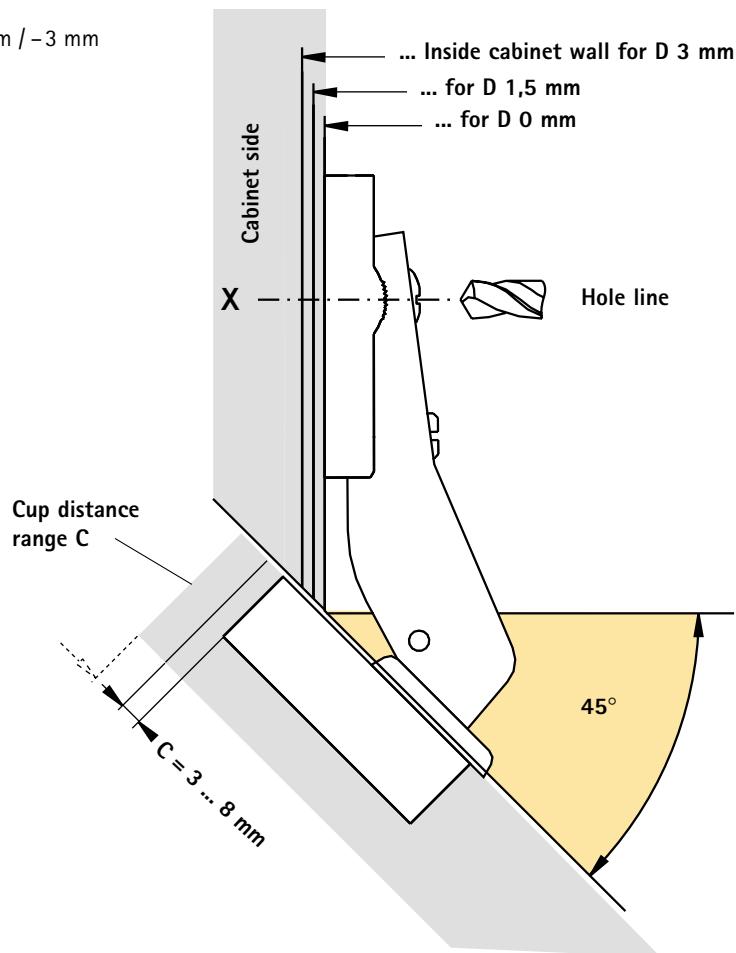

Scale 1:1

# Slide-on 2336 W90 Concealed hinge for face frame cabinets Opening angle 95°

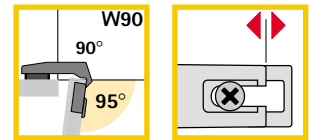

**Concealed hinge, slide-on attachment, integrated door overlay and reveal adjustment.**

Opening angle with 95°, cup diameter 35 mm.

For face frame cabinets.

Slide-on 2336 W90 hinges are attached by sliding them onto the mounting plate.

Depth adjustment +2 mm/-2 mm.

Height adjustment via mounting plate +2 mm/-2 mm, see page 3.148.

Cup fixing screw  $\varnothing$  3,5 x 13 mm nickel-plated, for cup T 42

Order no. 048 296, PU 200

## Cup version

### Cup T 42

Screw-on  
Nickel-plated steel

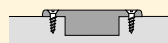

### Cup T 43

Press-in  
Nickel-plated steel



## Hinge version



Cranking 7,5 mm

## Mounting option

Inset

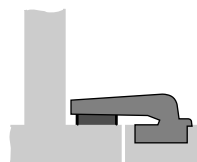

## Article/order number

### Hettich Slide-on 2336 W90

● self-closing

Packaging unit 50 pcs

● 2336 W90-T42

013 101

● 2336 W90-T43

013 102

## Specification

Hettich Slide-on 2336 W90

Concealed hinge

Slide-on assembly

Integrated door overlay and depth adjustment for 90° face frame applications

Opening angle 95°

| Cup distance<br>C mm  | Door thickness mm |     |     |     |     |     |     |     |     |     |     |     |     |     |     |     |     |
|---|-------------------|-----|-----|-----|-----|-----|-----|-----|-----|-----|-----|-----|-----|-----|-----|-----|-----|
|   | 16                | 17  | 18  | 19  | 20  | 21  | 22  | 23  | 24  | 25  | 26  | 27  | 28  | 29  | 30  | 31  | 32  |
| <b>Minimum reveal per door – allow for distance calculation</b> |                   |     |     |     |     |     |     |     |     |     |     |     |     |     |     |     |     |
| Values in table apply to doors with 0 mm radius                 |                   |     |     |     |     |     |     |     |     |     |     |     |     |     |     |     |     |
| 3   | 0,4               | 0,6 | 0,8 | 1,0 | 1,2 | 1,5 | 1,8 | 2,1 | 2,5 | 2,9 | 3,4 | 4,0 | 4,9 | 5,7 | 6,6 | 7,5 | 8,4 |
| 4   | 0,4               | 0,6 | 0,8 | 1,0 | 1,2 | 1,5 | 1,8 | 2,1 | 2,5 | 2,8 | 3,3 | 3,8 | 4,5 | 5,3 | 6,1 | 7,0 | 7,9 |
| 4,5   | 0,4               | 0,6 | 0,8 | 1,0 | 1,2 | 1,5 | 1,8 | 2,1 | 2,5 | 2,8 | 3,3 | 3,7 | 4,3 | 5,1 | 5,9 | 6,8 | 7,7 |
| 5   | 0,4               | 0,6 | 0,8 | 1,0 | 1,2 | 1,4 | 1,7 | 2,0 | 2,4 | 2,7 | 3,2 | 3,6 | 4,2 | 4,9 | 5,7 | 6,5 | 7,4 |
| 6   | 0,4               | 0,6 | 0,8 | 1,0 | 1,2 | 1,4 | 1,7 | 2,0 | 2,3 | 2,6 | 3,1 | 3,5 | 4,0 | 4,6 | 5,3 | 6,1 | 6,9 |
| 7   | 0,4               | 0,5 | 0,7 | 0,9 | 1,1 | 1,3 | 1,6 | 1,9 | 2,2 | 2,6 | 3,0 | 3,4 | 3,9 | 4,4 | 5,0 | 5,7 | 6,5 |
| 8   | 0,4               | 0,5 | 0,7 | 0,9 | 1,1 | 1,3 | 1,6 | 1,8 | 2,1 | 2,5 | 2,9 | 3,3 | 3,7 | 4,2 | 4,8 | 5,4 | 6,1 |

The minimum reveal is reduced for doors with radii: 1 mm radius: table entry – 0,4 mm  
3 mm radius: table entry – 1,2 mm

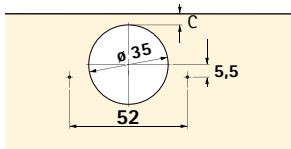

T42 hole dimensions

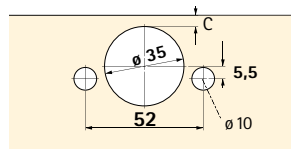

T43 hole dimensions

## Mounting example

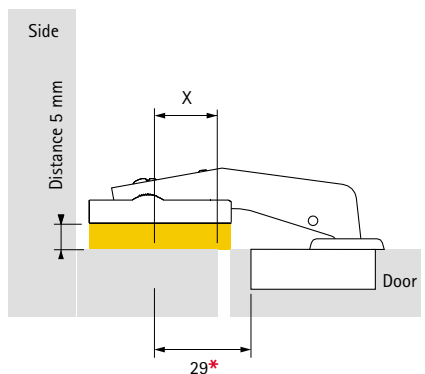
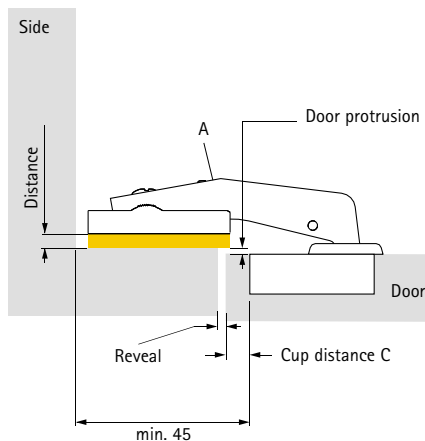

## Calculating distance

$$\text{Distance} = 6,5 \text{ mm} - \text{door protrusion}$$

The hinges are adjusted correctly ex factory.

The door protrusion can be adjusted if necessary.

Turn screw (A) clockwise:

The door protrusion can be adjusted by up to 3,5 mm (+0,5 mm/-3 mm), but not with C-dimension > 4 and 3 and 5 mm distance.

The back of the door and front panel will be flush if a mounting plate with distance 5 mm is used.







\* The hole distance X, cup distance C and the reveal must always add up to 29!

$$X + \text{cup distance C} + \text{reveal} = 29$$

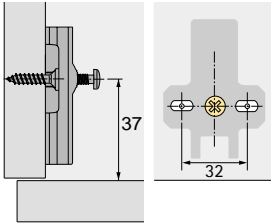
## Calculating hole distance "X"

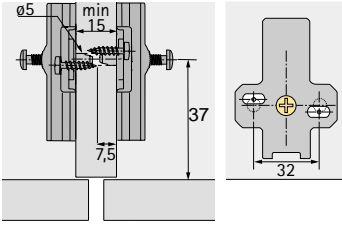
| Cup distance<br>C mm | Reveal mm |      |      |      |      |      |      |
|----------------------|-----------|------|------|------|------|------|------|
|                      | 0         | 0,5  | 1,0  | 1,5  | 2,0  | 2,5  | 3,0  |
| 3                    | 25,0      | 24,5 | 24,0 | 23,5 | 23,0 | 22,5 | 22,0 |
| 3,5                  | 24,5      | 24,0 | 23,5 | 23,0 | 22,5 | 22,0 | 21,5 |
| 4                    | 24,0      | 23,5 | 23,0 | 22,5 | 22,0 | 21,5 | 21,0 |
| 4,5                  | 23,5      | 23,0 | 22,5 | 22,0 | 21,5 | 21,0 | 20,5 |
| 5                    | 23,0      | 22,5 | 22,0 | 21,5 | 21,0 | 20,5 | 20,0 |
| 5,5                  | 22,5      | 22,0 | 21,5 | 21,0 | 20,5 | 20,0 | 19,5 |
| 6                    | 22,0      | 21,5 | 21,0 | 20,5 | 20,0 | 19,5 | 19,0 |
| 7                    | 21,0      | 20,5 | 20,0 | 19,5 | 19,0 | 18,5 | 18,0 |
| 8                    | 20,0      | 19,5 | 19,0 | 18,5 | 18,0 | 17,5 | 17,0 |

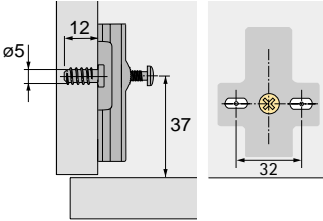
# Mounting plate system 2006 for Slide-on hinges

| Article   |   | Distance Hole line                    | Distance (D) | Total height | Order no. |
|---|---|---------------------------------------|--------------|--------------|-----------|
| <b>Screw-on wing mounting plate</b><br>Hole distance 32 mm, with oblong holes $\varnothing$ 5,4 mm for height adjustment, premounted hinge arm fixing screw<br>nickel-plated steel<br>PU = 50 pcs   |     | <b>37 mm</b>                          | 0 mm         | 6,5 mm       | 013 103*  |
|   |   |                                       | 1,5 mm       | 8,0 mm       | 010 195   |
|   |   |                                       | 3,0 mm       | 9,5 mm       | 010 196   |
|   |   |                                       | 5,0 mm       | 11,5 mm      | 010 197   |
| * not suitable for 2333 cranking 0 mm<br><br>Fixing with countersunk wood screws $\varnothing$ 4,5 mm   |   |                                       |              |              |           |
| <b>Patented screw-on wing mounting plate "Hettich Direkt"</b><br>Hole distance 32 mm, with premounted hinge arm fixing screw, pre-mounted locating pegs and asymmetrically positioned special screws for drillings $\varnothing$ 5 x 7,5 mm<br>Oblong holes for height adjustment, nickel-plated steel<br>PU = 50 pcs |      | <b>37 mm</b>                          | 1,5 mm       | 8,0 mm       | 010 201   |
|   |   |                                       | 3,0 mm       | 9,5 mm       | 010 202   |
|   |   |                                       | 5,0 mm       | 11,5 mm      | 010 203   |
|   |   | * not suitable for 2333 cranking 0 mm |              |              |           |
| <b>Screw-on wing mounting plate</b><br>Hole distance 32 mm, with premounted hinge arm fixing screw, premounted Euro screws for drillings $\varnothing$ 5 x 12 mm oblong holes for height adjustment, nickel-plated steel<br>PU = 50 pcs   |    | <b>37 mm</b>                          | 0 mm         | 9,0 mm       | 013 120*  |
|   |   |                                       | 1,5 mm       | 10,5 mm      | 010 198   |
|   |   |                                       | 3,0 mm       | 12,0 mm      | 010 199   |
|   |   |                                       | 5,0 mm       | 14,0 mm      | 010 200   |
| * not suitable for 2333 cranking 0 mm   |   |                                       |              |              |           |

3

# System 2006 angle mounting plates and parallel distance plates for Slide-on hinges



| Article  | Distance Hole line | Distance                    | Total height                | Order no.                     |
|--|--------------------|-----------------------------|-----------------------------|-------------------------------|
| <p><b>Angle plate for wing mounting plate</b><br/>silver-grey plastic<br/>PU = 50 pcs</p> <p>Only suitable for use with screw-on wing mounting plates order no. 013 103, 010 195 – 010 197 (see page 3.148)</p>  | 37 mm              | 5°<br>10°                   | 5,0 mm<br>10,0 mm           | 079 349<br>079 350            |
| <p><b>Assembly note angle plates 5°/10°:</b></p> <p><b>1. Sockets</b></p> <p>Socket no. 41<br/>Order no. 048 575<br/>PU 200 pcs</p> <p>or</p> <p>Socket no. 42<br/>Order no. 048 574<br/>PU 200 pcs</p> <p>Insert in ø 5 mm hole line drilling.</p> <p><b>2. Mounting and angle plates</b><br/>Fasten with chipboard screws ø 4 mm or ø 4,5 mm.</p> <p>Simply turn the plastic angle mounting plates to either increase or reduce the cabinet angle. Angle mounting plates and parallel distance plates are stackable.</p> |                    |                             |                             |                               |
| <p><b>Distance spacer plate for wing mounting plate</b><br/>Silver-grey plastic<br/>PU = 50 pcs</p> <p>Only suitable for use with screw-on wing mounting plates order no. 013 103, 010 195 – 010 197 (see page 3.148)</p>  | 37 mm              | 3,0 mm<br>5,0 mm<br>10,0 mm | 3,0 mm<br>5,0 mm<br>10,0 mm | 079 323<br>079 324<br>079 325 |



# Unimat



# Unimat – new hinge generation with instant design appeal



3

Unimat is Hettich's new, integral hinge family. Unimat is a completely new hinge type - a one-piece hinge with an enchantingly attractive design. The smooth curves of tough steel and their petite size add to the many benefits offered by the Unimat hinge.

## All of a piece

As a one-piece hinge with captive screws, a Unimat has a component count of precisely one. Unimat – simply unique in the world of hinges.

The hinge body and mounting plate are all in one, with captive screws. Logistics and scheduling are easier with Unimat!



design award  
winner  
**2002**

# Unimat

## Deceptive simplicity, sophisticated engineering



For all its aesthetic appeal, Unimat is far more than just an attractive design and a quality finish. Hettich development engineers have devised a hinge where stability, quality and practicality can count as best in class. Fast and easy fitting and no possibility of errors benefits manufacturers and end-users alike. Unimat is right for standard doors and frame constructions.

The cup depth of 10 mm reduces this important parameter to a minimum, making Unimat ideal for use with very thin chip-board. Compatible with System 32, Unimat

is right for the popular 37 mm hole line with different crankings for full overlay, half overlay and inset doors. Easy-adjust screws align the door in seconds.

A bevel around the cup covers any rough edges round the drill hole in the wood – a fast and effective way to achieve a neat, well-fitting look.





3



# Unimat

The patented Hettich Direkt principle is fully implemented with Unimat too, ensuring maximum pull-out strength and allowing it to be used even with 15 mm thick centre uprights.

No mounting errors, so simple to fit, stable in place - it's all so easy with Unimat.

Locating pegs combined with asymmetrically rounded, pre-mounted special screws.

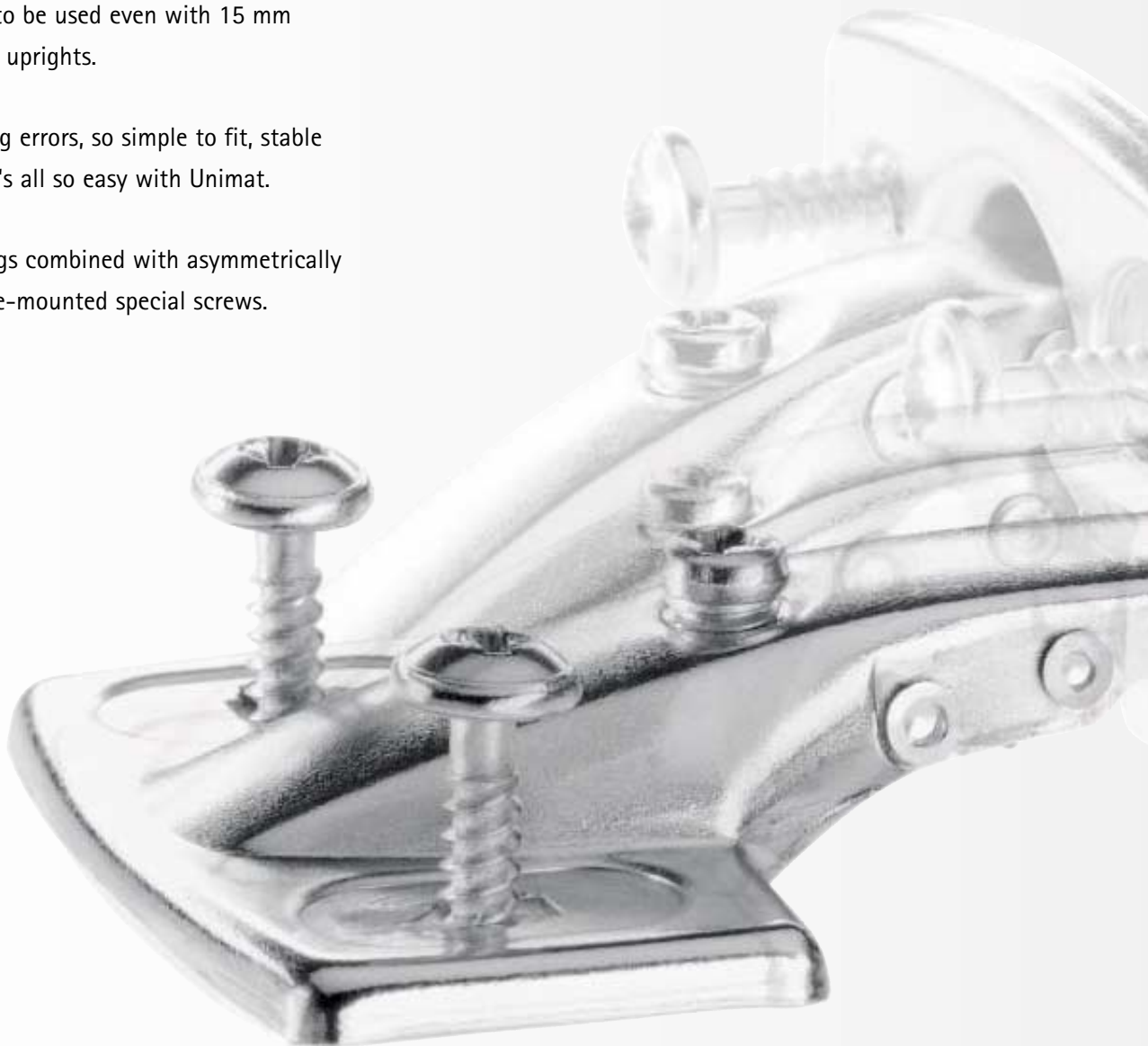



**Hettich-Direkt:** an idea carries the day

3



# Technical information

## Mounting options:

There are three basic methods of mounting hinges

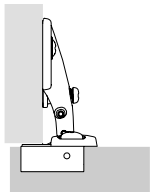

### Full overlay:

In this configuration, the door is positioned in front of a cabinet side panel. The reveal at one side is such that the door can be opened safely.

Cranking 0/4 mm

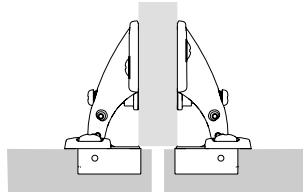

### Half overlay:

In this configuration, two doors are positioned in front of the middle wall of a cabinet. The distance between the doors is the total required reveal. The door overlay is reduced which necessitates the use of cranked hinges.

Cranking 8 mm

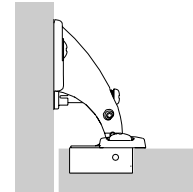

### Inset:

In this configuration, the door is positioned inside a cabinet side panel. A reveal is required for opening the door. This configuration necessitates the use of heavily cranked hinges.

Cranking 15,5 mm

## Minimum door reveal:

The minimum reveal, also referred to as the door clearance, is the space that has to be allowed at the side for a door to open. The minimum reveal dimension depends on the cup distance C and the door thickness, as well as the type of hinge used A radius at the door edge reduces the door clearance. The minimum reveal required is shown in the chart for the type of hinge.

In the case of a half overlay application, the total gap between the doors should be not less than twice the door clearance, to allow both doors to be opened at the same time.

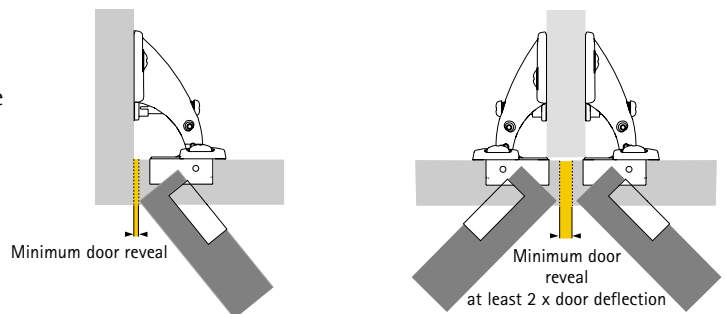

## Cup distance C

The cup distance C is the distance between the edge of the door and the edge of the cup hole. The larger the cup distance, the smaller the required minimum reveal.

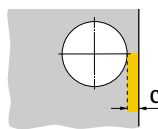

## Overlay A (Door overlay):

The door overlay is the distance by which the door projects over the cabinet front.

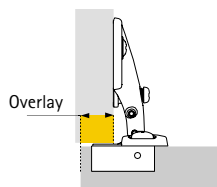

## Reveal

The reveal is the distance between the outer edge of the door and the outer side of the cabinet (full overlay), the distance between two doors (half overlay), the distance between the outer edge of the door and the inner side of the cabinet (inset).

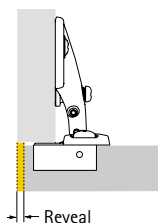

## Number of hinges per door:

Door width, door height, door weight and door material are the key factors for determining the required number of hinges. In practice, these factors are very variable. The numbers listed in the diagram are for reference only. A trial mounting is recommended if in doubt.

Maximum stability is obtained by choosing the distance between hinges as large as possible.

**X = Distance between two hinges**

(Reference values for 19 mm thick chipboard with a density of 750 kg/m<sup>3</sup>)

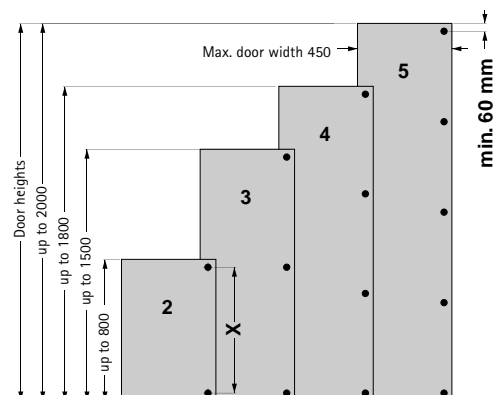



## Assembly

Unimat hinges are preassembled for fast and easy furniture assembly.

### 1 Inserting

First insert the hinge cup centrally in the hole of the door.

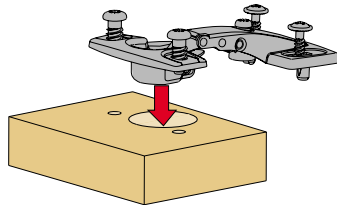

### 2 Screw in

Then tighten the premounted screws (e.g. using a cordless screwdriver)

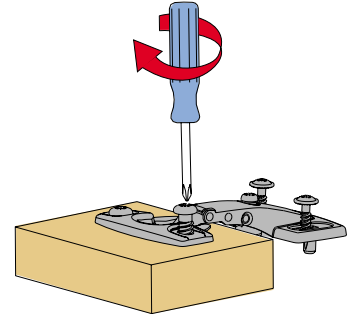

### 3 Plug in

With the hinge fixed to the door insert the Hettich-Direkt pilot pins in the standard hole line of the side panel.

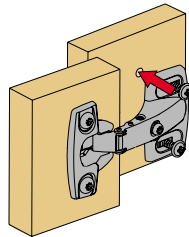

### 4 Screw fixing

Finally tighten the screws of the Hettich-Direkt system.

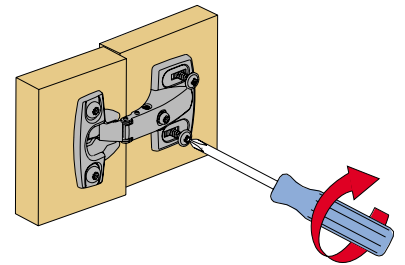

3

## Door adjustment:

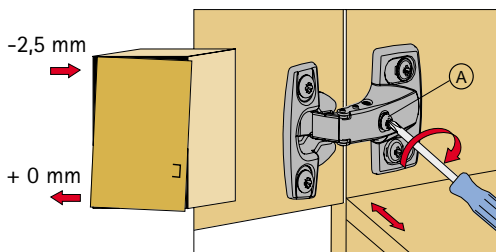

### Overlay adjustment

Turn screw (A) in the centre of the hinge arm clockwise to reduce the door overlay (side adjustment).

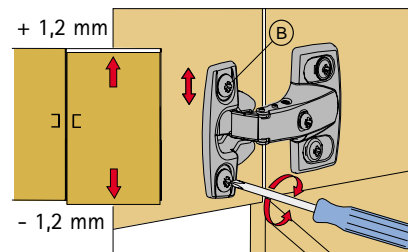

### Height adjustment

Adjust the door height by slightly loosening screws (B) on all hinge cups. Adjust the height of the door by hand, then retighten the screws.

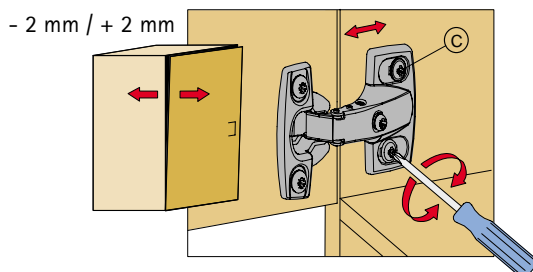

### Depth adjustment

Adjust the hinge depth by slightly loosening screws (C) on the hinge arm. Adjust the clearance between door and cabinet by hand, then retighten the screws.

# Unimat 1128

## Design mini hinge

### Opening angle 95°

For door thicknesses from 14 mm

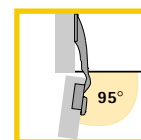

#### Unimat

**Design mini hinge with an integral mounting plate in the hinge arm, self-closing and with overlay adjustment.**

**Attractive design, concealed spring system, cup with rim.**

Opening angle 95°, cup diameter 26 mm.

Pre-mounted self-tapping screws or Euro screws in the hinge cup.

Hettich Direkt mounting system with locating pegs and pre-mounted special screws for holes dia. 5 x 7,5 mm.

Depth adjustment via oval holes in hinge arm + 2 mm/- 2 mm.

Height adjustment via oval holes in hinge head + 1,2 mm/-1,2 mm.

The mounting plates with sockets are colour-coded to facilitate the correct choice of hinge cranking: blue 0 mm, yellow 4 mm, green 8 mm, white 15,5 mm cranking.

#### Cup version

##### Cup T42/33

Screw-on  
with pre-mounted  
chipboard screws  
Nickel-plated steel

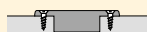

##### Cup T42/30

Screw-on  
with pre-mounted  
Euro screws  
Nickel-plated steel



#### Hinge version

Cranking 0 mm



#### Mounting option

Full overlay

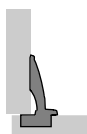

#### Article/order number

##### Unimat 1128

● self-closing

Packaging unit 50 pcs

● 1128 -  
T42/33

042 523

● 1128 -  
T42/30

042 527

Cranking 4 mm



Full overlay

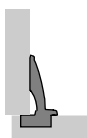

##### Unimat 1128

● self-closing

Packaging unit 50 pcs

● 1128 -  
T42/33

042 524

● 1128 -  
T42/30

042 528

Cranking 8 mm



Half overlay

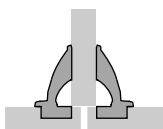

##### Unimat 1128

● self-closing

Packaging unit 50 pcs

● 1128 -  
T42/33

042 525

● 1128 -  
T42/30

042 529

Cranking 15,5 mm



Inset

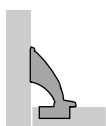

##### Unimat 1128

● self-closing

Packaging unit 50 pcs

● 1128 -  
T42/33

042 526

● 1128 -  
T42/30

042 531

## Specification

Hettich Unimat 1128

Design mini hinge

Hinge and mounting plate all in one

Cup diameter 26 mm

for doors with narrow frames

| Cup distance<br>C mm  | Door thickness mm |     |     |     |     |     |     |     |
|---|-------------------|-----|-----|-----|-----|-----|-----|-----|
|   | 14                | 15  | 16  | 17  | 18  | 19  | 20  | 21  |
| <b>Minimum reveal per door – allow for in distance calculation</b><br>Table entries apply to doors with 0 mm radius |                   |     |     |     |     |     |     |     |
| 3,0   | 0,6               | 0,8 | 1,1 | 1,3 | 1,7 | 2,0 | 2,8 | 3,7 |
| 3,5   | 0,6               | 0,8 | 1,1 | 1,3 | 1,7 | 2,0 | 2,6 | 3,5 |
| 4,0   | 0,6               | 0,8 | 1,0 | 1,3 | 1,6 | 2,0 | 2,4 | 3,2 |
| 4,5   | 0,6               | 0,8 | 1,0 | 1,3 | 1,6 | 1,9 | 2,3 | 3,0 |
| 5,0   | 0,6               | 0,7 | 1,0 | 1,3 | 1,6 | 1,9 | 2,3 | 2,8 |

The minimum reveal is reduced for doors with radii: 1 mm radius: table entry – 0,3 mm  
3 mm radius: table entry – 0,7 mm

Values in the shaded area of the chart are not suitable for inset applications.

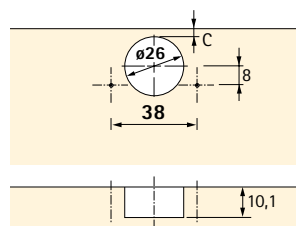

T42/33 hole dimensions

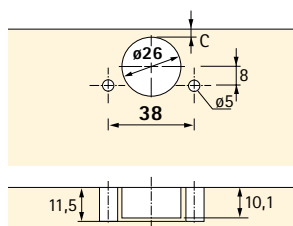

T42/30 hole dimensions

### Door protrusion T

Dimensions refer to a 3 mm cup distance, without using overlay adjustment

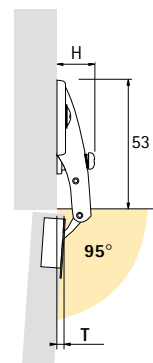

| Cranking mm | H mm | T mm |
|-------------|------|------|
| 0           | 15   | 7    |
| 4           | 19   | 11   |
| 8           | 21   | 15   |
| 15,5        | 28,4 | 22,5 |

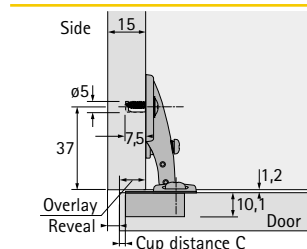

### Cup distance C mm

### Overlay mm

|     |      |
|-----|------|
| 3   | 12   |
| 3,5 | 12,5 |
| 4   | 13   |
| 4,5 | 13,5 |
| 5   | 14   |

\* Overlay adjustment + 0 mm, – 2,5 mm

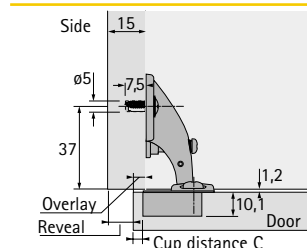

### Cup distance C mm

### Overlay mm

|     |     |
|-----|-----|
| 3   | 8   |
| 3,5 | 8,5 |
| 4   | 9   |
| 4,5 | 9,5 |
| 5   | 10  |

\* Overlay adjustment + 0 mm, – 2,5 mm

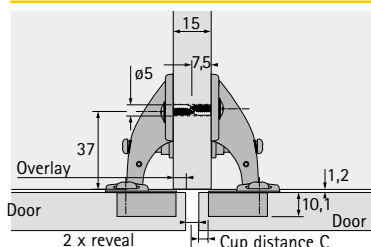

### Cup distance C mm

### Overlay mm

|     |     |
|-----|-----|
| 3   | 4   |
| 3,5 | 4,5 |
| 4   | 5   |
| 4,5 | 5,5 |
| 5   | 6   |

\* Overlay adjustment + 0 mm, – 2,5 mm

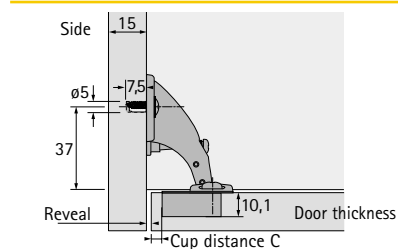

### Cup distance C mm

### Reveal mm

|     |     |
|-----|-----|
| 3   | 3,5 |
| 3,5 | 3   |
| 4   | 2,5 |
| 4,5 | 2   |
| 5   | 1,5 |

\* Overlay adjustment – 0 mm, + 2,5 mm

# Unimat 1108

## Design mini hinge for glass doors

### Opening angle 95°

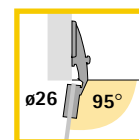

#### Unimat

**Design mini hinge for glass doors with an integral mounting plate in the hinge arm, self-closing and with overlay adjustment. Concealed spring system, cup with rim.**

Opening angle 95°, cup diameter 26 mm.

Hettich Direkt mounting system with locating pegs and pre-mounted special screws for holes dia. 5 x 7,5 mm.

For glass doors with a glass panel thickness of 4 - 6,5 mm.

For a glass panel thickness from 5,5 mm, order 2 x cup fixing screws – Order no. 069 611, PU 1000.

Decorative caps in various finishes, see page 3.161.

Depth adjustment via oval holes in hinge arm + 2 mm/- 2 mm.

The mounting plates with sockets are colour-coded to facilitate the correct choice of hinge cranking: blue 0 mm, yellow 4 mm, green 8 mm, white 15,5 mm cranking.

#### Cup version

##### Cup T1

Screw-on  
Black plastic



#### Hinge version

Cranking 0 mm



#### Mounting option

Full overlay

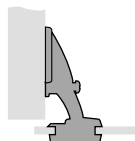

#### Article/order number

##### Unimat 1108

● self-closing

Packaging unit 50 pcs

● 1108 - T1

048 367

Cranking 4 mm



Full overlay

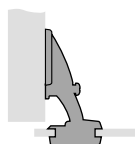

##### Unimat 1108

● self-closing

Packaging unit 50 pcs

● 1108 - T1

048 368

Cranking 8 mm



Half overlay

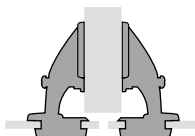

##### Unimat 1108

● self-closing

Packaging unit 50 pcs

● 1108 - T1

048 370

Cranking 15,5 mm



Inset

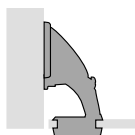

##### Unimat 1108

● self-closing

Packaging unit 50 pcs

● 1108 - T1

048 371

## Specification

Hettich Unimat 1108

Design mini hinge for glass doors

Hinge and mounting plate all in one

Cup diameter 26 mm

| Finish            | Order no. | PU |
|-------------------|-----------|----|
| high-gloss gold   | 040 340   | 50 |
| high-gloss chrome | 040 341   | 50 |
| black             | 070 051   | 50 |
| matt nickel       | 070 712   | 50 |
| metallic brown    | 040 342   | 50 |

Door protrusion T  
for 0 mm  
distance  
and 5,5 mm  
cup distance

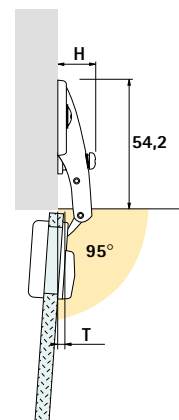

### Decorative cap A

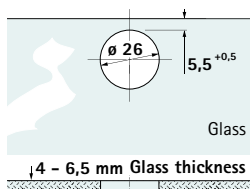

### T1 hole dimensions

| Cranking<br>mm | H<br>mm | T<br>mm |
|----------------|---------|---------|
| 0              | 15      | 7       |
| 4              | 19      | 11      |
| 8              | 21      | 15      |
| 15,5           | 28,4    | 22,5    |

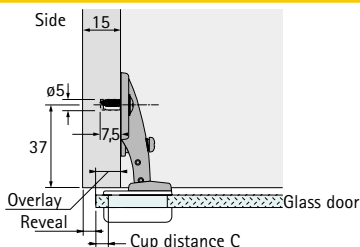

Cranking 0 mm  
Cup distance 5,5 mm  
C distance 5,5 mm  
Overlay 14,5 mm

\* Overlay adjustment + 0 mm, - 2,5 mm

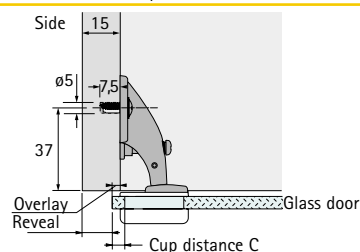

Cranking 4 mm  
Cup distance 5,5 mm  
C distance 5,5 mm  
Overlay 10,5 mm

\* Overlay adjustment + 0 mm, - 2,5 mm

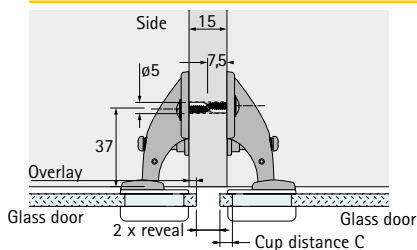

Cranking 8 mm  
Cup distance 5,5 mm  
C distance 5,5 mm  
Overlay 6,5 mm

\* Overlay adjustment + 0 mm, - 2,5 mm

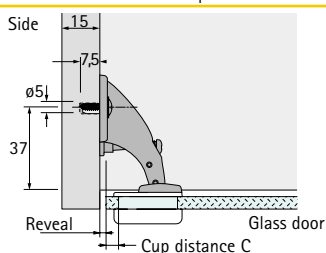

Cranking 15,5 mm  
Cup distance 5,5 mm  
C distance 5,5 mm  
Reveal 1 mm

\* Reveal adjustment - 0 mm, + 2,5 mm

# Perfekt



## Concealed hinge for display cases and corner cabinets

Modern furniture design often requires extraordinary technical solutions. With its special hinge programme for display cases and corner cabinets, once again Hettich demonstrates its ability to offer an optimal solution for any fitting problem.

### **Proven function**

Proven spring mechanism for high load.  
With self-closing function.

### **Completely in metal**

All hinges are entirely in metal and therefore extremely hard-wearing.

### **Also for frame doors**

The hinges with a 26 mm cup diameter are particularly suitable for doors with narrow frames.

### **For all mounting types**

The angle hinges can be used for overlay and inset door mountings. Glass door hinges are also included in the program.



Modern furniture design requires extraordinary solutions ...

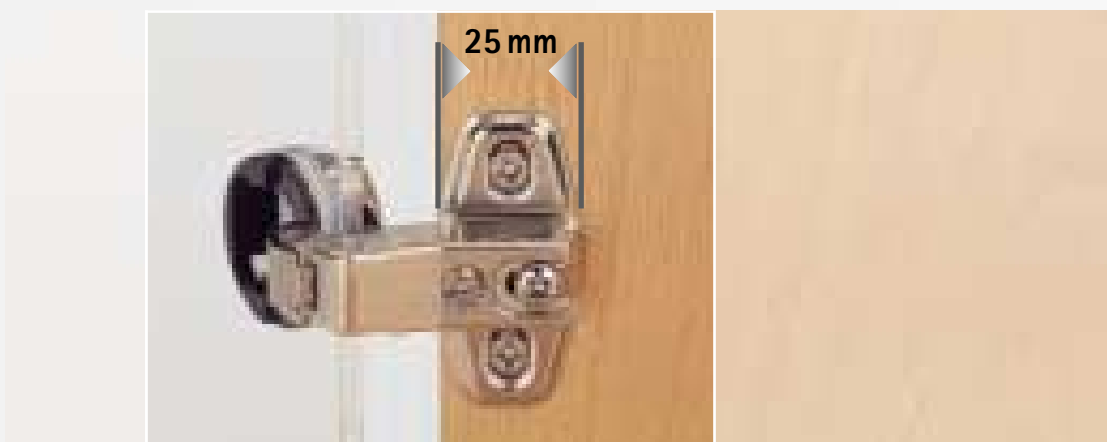

# Perfekt 5737 W45 Perfekt 5224 W45 Concealed hinge for 45° face angle

**Specification**  
Hettich Perfekt 5737 W45  
Hettich Perfekt 5224 W45  
Inset  
45° face angle  
Slide on assembly  
Opening angle 95°  
For cabinets with blind panels

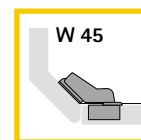

Hinge version



**Hettich Perfekt 5737 W45**  
**Concealed hinge with short hinge arm for inset doors.**  
Opening angle 95°, cup diameter 35 mm.  
For corner cabinets with blind panels.  
Perfekt hinges are attached by sliding them onto the mounting plate.  
Height adjustment via mounting plate +1,5/-1,5 mm.

### Cup version

**Cup T42**  
Screw-on  
Nickel-plated steel

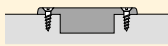

### Article/order number

**Perfekt 5737 W45**  
**with mounting plate**

● self-closing

PU 10 pcs

● **5737 W45-T42**  
**069 597**

### Mounting example

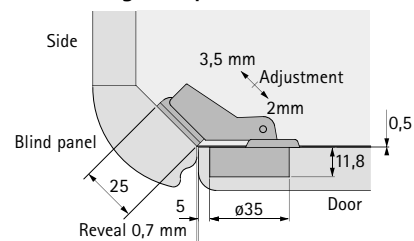

**Screw-on wing mounting plate**  
with oblong holes  $\varnothing$  4,2 mm

Distance 0 mm

Nickel-plated steel

Fixing with countersunk screws  $\varnothing$  4 mm



Hinge version



**Hettich Perfekt 5224 W45**  
**Concealed hinge with short hinge arm for inset doors.**  
Opening angle 95°, cup diameter 26 mm.  
For small cabinets with blind panels.  
Perfekt hinges are attached by sliding them onto the mounting plate.  
Height adjustment via mounting plate +1,5/-1,5 mm.

### Cup version

**Cup T42/26**  
Screw-on  
Nickel-plated steel

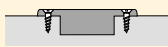

### Article/order number

**Perfekt 5224 W45**  
**with mounting plate**

● self-closing

PU 10 pcs

● **5224 W45-T42**  
**069 599**

### Mounting example

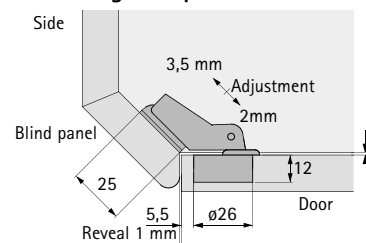

**Screw-on wing mounting plate**  
with oblong holes  $\varnothing$  4,2 mm

Distance 0 mm

Nickel-plated steel

Fixing with countersunk screws  $\varnothing$  4 mm

# Perfekt 5204 W45 Concealed glass door hinge for 45° face angle

**Specification**  
Hettich Perfekt 5204 W45  
Inset  
45° face angle  
Slide-on assembly  
Opening angle 95°  
for glass doors  
door hole  $\varnothing$  26 mm, glass thickness 4 - 6,5 mm

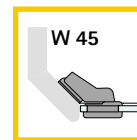

Hinge version

## Hettich Perfekt 5204 W45 Concealed glass door hinge with short hinge arm for inset doors.

Opening angle 95°, glass door hole 26 mm, for a glass panel thickness of 4 - 6,5 mm.

For a glass panel thickness from 5,5 mm cup fixing screws are supplied

For corner cabinets with blind panels.

Perfekt hinges are attached by sliding them onto the mounting plate.

Height adjustment via mounting plate +1,5/-1,5 mm.

### Cup version

**Cup T1**  
Screw-on  
Black plastic

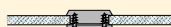

### Mounting example

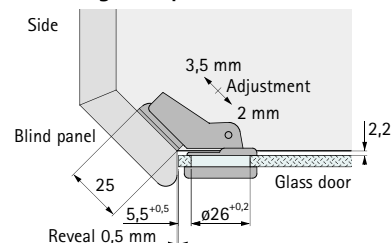

Article/order number

### Perfekt 5204 W45 with mounting plate

- self-closing

PU 10 pcs

● 5204 W45-T1  
**069 600**

### Screw-on wing mounting plate with oblong holes $\varnothing$ 4,2 mm

Distance 0 mm

Nickel-plated steel

Fixing with countersunk screws  $\varnothing$  4 mm



Decorative cap A



Decorative cap B



| Finish            | Order no. | VE |
|-------------------|-----------|----|
| high-gloss gold   | 040 340   | 50 |
| high-gloss chrome | 040 341   | 50 |
| black             | 070 051   | 50 |
| matt nickel       | 070 712   | 50 |
| metallic brown    | 040 342   | 50 |

| Finish            | Order no. | VE |
|-------------------|-----------|----|
| high-gloss gold   | 040 494   | 50 |
| high-gloss chrome | 040 495   | 50 |
| black             | 070 052   | 50 |
| matt nickel       | 070 713   | 50 |

# Perfekt 5224 W60 Perfekt 5204 W60 Concealed hinges for 60° face angle

**Specification**  
Hettich Perfekt 5224 W60  
Cup diameter  $\varnothing$  26 mm  
Hettich Perfekt 5204 W60  
for glass doors, cup hole  $\varnothing$  26 mm,  
glass thickness 4 - 6,5 mm  
60° face angle, slide-on assembly  
Opening angle 95°

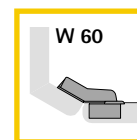

Hinge version



## Hettich Perfekt 5224 W60 Concealed hinge with short hinge arm for inset doors.

Opening angle 95°, cup diameter 26 mm.  
For small cabinets with blind panels.  
Perfekt hinges are attached by sliding them onto the mounting plate.  
Height adjustment via mounting plate +1,5/-1,5 mm.

### Cup version

**Cup T 42**  
Screw-on  
Nickel-plated steel

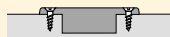

### Article/order number

**Perfekt 5224 W60  
with mounting plate**  
● self-closing **PU 10 pcs**

● **5224 W60-T 42/26**  
**069 601**

### Mounting example

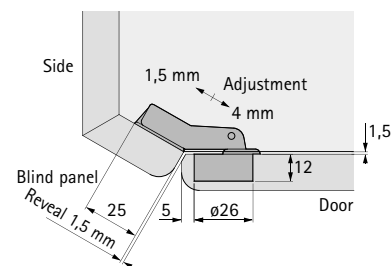

**Screw-on wing mounting plate**  
with oblong holes  $\varnothing$  4,2 mm

Distance 0 mm  
Nickel-plated steel  
Fixing with countersunk screws  $\varnothing$  4 mm



Hinge version



## Hettich Perfekt 5204 W60 Concealed glass door hinge with short side arm for inset doors.

Opening angle 95°, glass door hole 26 mm, for a glass panel thickness of 4 - 6,5 mm. For a glass panel thickness from 5,5 mm cup fixing screws are supplied.  
For corner cabinets with blind panels.  
Perfekt hinges are attached by sliding them onto the mounting plate.  
Height adjustment via mounting plate +1,5/-1,5 mm.  
For decorative caps, see page 3.165

### Cup version

**Cup T 1**  
Screw-on  
Black plastic



### Article/order number

**Perfekt 5204 W60  
with mounting plate**  
● self-closing **PU 10 pcs**

● **5204 W60-T 1**  
**069 602**

### Mounting example

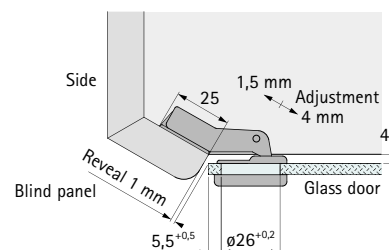

**Screw-on wing mounting plate**  
with oblong holes  $\varnothing$  4,2 mm

Distance 0 mm  
Nickel-plated steel  
Fixing with countersunk screws  $\varnothing$  4 mm

# Perfekt 5734 W90 Perfekt 5737 W90 Concealed hinges for cabinets with blind panels

**Specification**  
Hettich Perfekt 5734 W90  
Hettich Perfekt 5737 W90  
**Overlay or inset**  
For 90° cabinet constructions  
Slide-on assembly  
Opening angle 95°

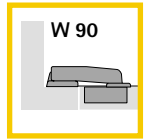

Hinge version



## Hettich Perfekt 5737 W90 Concealed hinge with short hinge arm for inset doors.

Opening angle 95°, cup diameter 35 mm.  
For corner cabinets with blind panels.  
Perfekt hinges are attached by sliding them onto the mounting plate.  
Height adjustment via mounting plate +1,5/-1,5 mm.

### Cup version

**Cup T 42**  
Screw-on  
Nickel-plated steel



### Article/order number

#### Perfekt 5737 W90 with mounting plate

- self-closing

PU 10 pcs

● 5737 W90-T 42  
**069 603**

### Mounting example

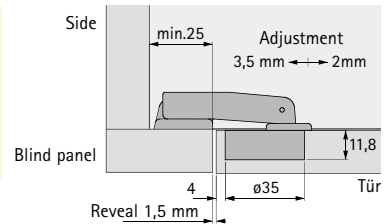

#### Screw-on wing mounting plate with oblong holes ø 4,2 mm

Distance 0 mm  
Nickel-plated steel  
Fixing with countersunk screws ø 4 mm

3



Hinge version



## Hettich Perfekt 5734 W90 Concealed hinge with short hinge arm for overlay doors.

Opening angle 95°, cup diameter 35 mm.  
For corner cabinets with blind panels.  
Perfekt hinges are attached by sliding them onto the mounting plate.  
Height adjustment via mounting plate +1,5/-1,5 mm.

### Cup version

**Cup T 42**  
Screw on  
Nickel-plated steel

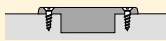

### Article/order number

#### Perfekt 5734 W90 with mounting plate

- self-closing

PU 10 pcs

● 5734 W90-T 42  
**069 605**

### Mounting example

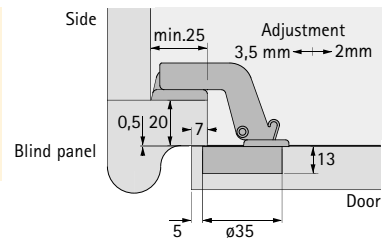

#### Screw-on wing mounting plate with oblong holes ø 4,2 mm

Distance 0 mm  
Nickel-plated steel  
Fixing with countersunk screws ø 4 mm

# Perfekt 5224 W90 Perfekt 5204 W90 Concealed hinges for 90° face angle

## Specification

Hettich Perfekt 5224 W90

Cup diameter  $\varnothing$  26 mm

Hettich Perfekt 5204 W90

For glass doors, cup diameter  $\varnothing$  26 mm,

glass thickness 4 - 6,5 mm

for 90° cabinet constructions

Slide-on attachment, opening angle 90°

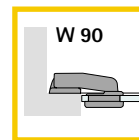
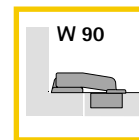

Hinge version



## Hettich Perfekt 5224 W90

Concealed hinge with short hinge arm for inset doors.

Opening angle 95°, cup diameter 26 mm.

For small cabinets with blind panels.

Perfekt hinges are attached by sliding them onto the mounting plate.

Height adjustment via mounting plate +1,5/-1,5 mm.

### Cup version

Cup T 42/26

Screw-on

Nickel-plated steel

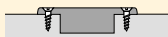

### Mounting example

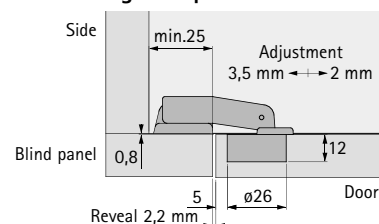

### Article/order number

Perfekt 5224 W90

with mounting plate

● self-closing

PU 10 pcs

● 5224 W90-T 42/26

069 609

Screw-on wing mounting plate

with oblong holes  $\varnothing$  4,2 mm

Distance 0 mm

Nickel-plated steel

Fixing with countersunk screws  $\varnothing$  4 mm



Hinge version



## Hettich Perfekt 5204 W90

Concealed glass door hinge with short side arm for inset doors.

Opening angle 95°, glass door hole 26 mm, for a glass panel thickness of 4 - 6,5 mm.

For a glass panel thickness from 5,5 mm cup fixing screws are supplied

For corner cabinets with blind panels.

Perfekt hinges are attached by sliding them onto the mounting plate.

Height adjustment via mounting plate +1,5/-1,5 mm.

For decorative caps, see page 3.169

### Cup version

Cup T 1

Screw-on

Black plastic



### Mounting example

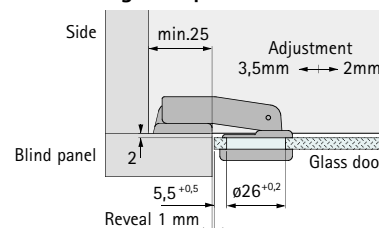

### Article/order number

Perfekt 5204 W90

with mounting plate

● self-closing

PU 10 pcs

● 5204 W90-T 1

069 607

Screw-on wing mounting plate

with oblong holes  $\varnothing$  4,2 mm

Distance 0 mm

Nickel-plated steel

Fixing with countersunk screws  $\varnothing$  4 mm

---

Decorative cap A



| Finish            | Order no. | PU |
|-------------------|-----------|----|
| high-gloss gold   | 040 340   | 50 |
| high-gloss chrome | 040 341   | 50 |
| black             | 070 051   | 50 |
| matt nickel       | 070 712   | 50 |
| metallic brown    | 040 342   | 50 |

Decorative cap B



| Finish            | Order no. | PU |
|-------------------|-----------|----|
| high-gloss gold   | 040 494   | 50 |
| high-gloss chrome | 040 495   | 50 |
| black             | 070 052   | 50 |
| matt nickel       | 070 713   | 50 |

# Selekta Pro 2000

## The program

- opening angles 180°, 230° and 270°
- for single cabinet and storage wall construction
- with and without self-closing  
... for different constructions
- with pre-mounted pan-head screws
- with eccentric height adjustment  $\pm 2$  mm

3

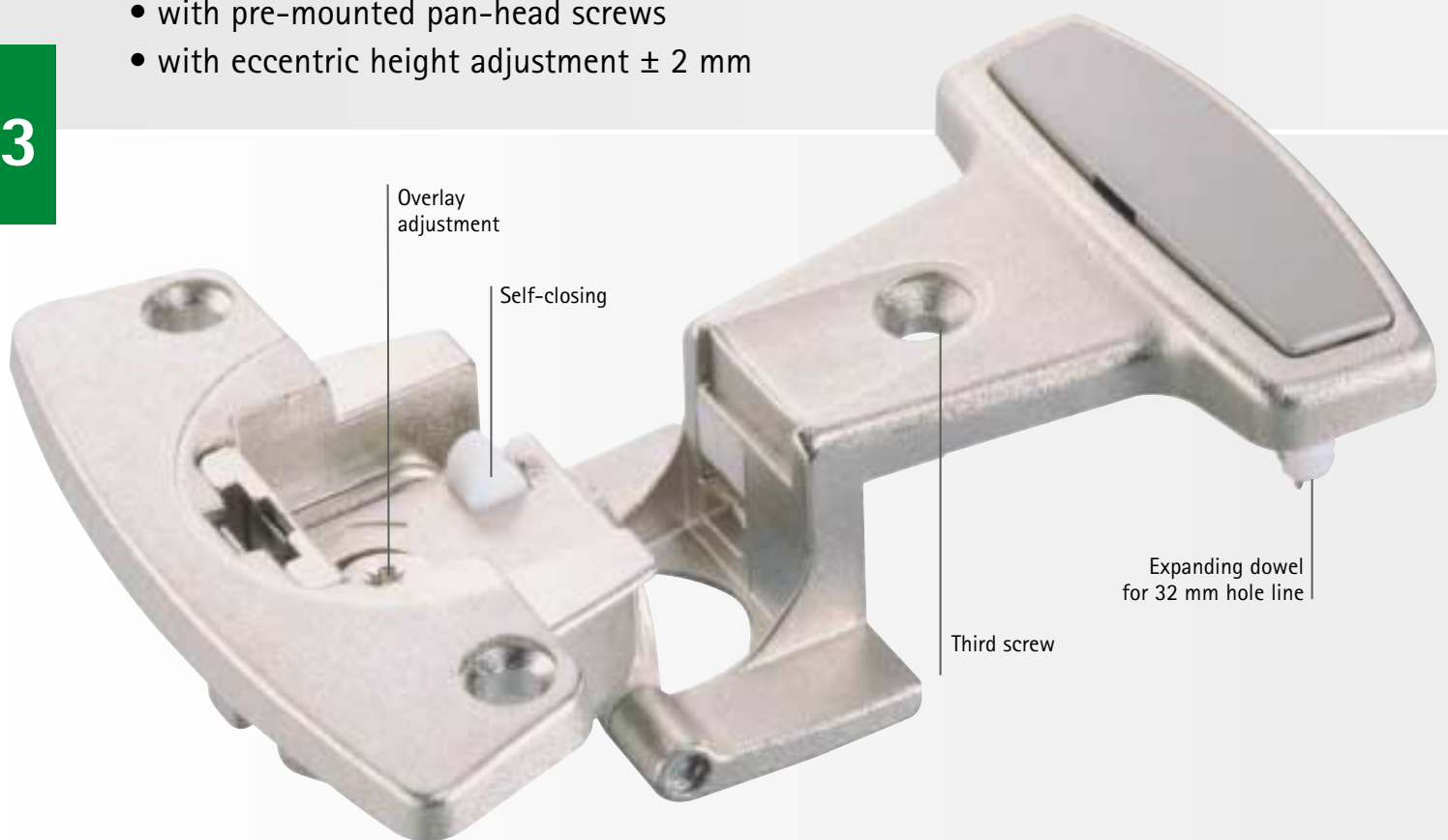

Perfect **Function**  
**attractive** design

# Fast-assembly hinge for office and commercial furniture

Light finger pressure is enough  
and the hinge is securely and  
quickly mounted.



Disassembly  
with a screw driver



Overlay adjustment  
with eccentric screw (-2 mm)



Height adjustment  
with eccentric screw ( $\pm 2$  mm)



# Selekta Pro 2000



Cup depth 13 mm for all Selekta Pro 2000 hinges



Selekta Pro 2000  
Opening angle stop for 90° and 115°

3

## Assembly Opening angle stop for Selekta Pro 2000

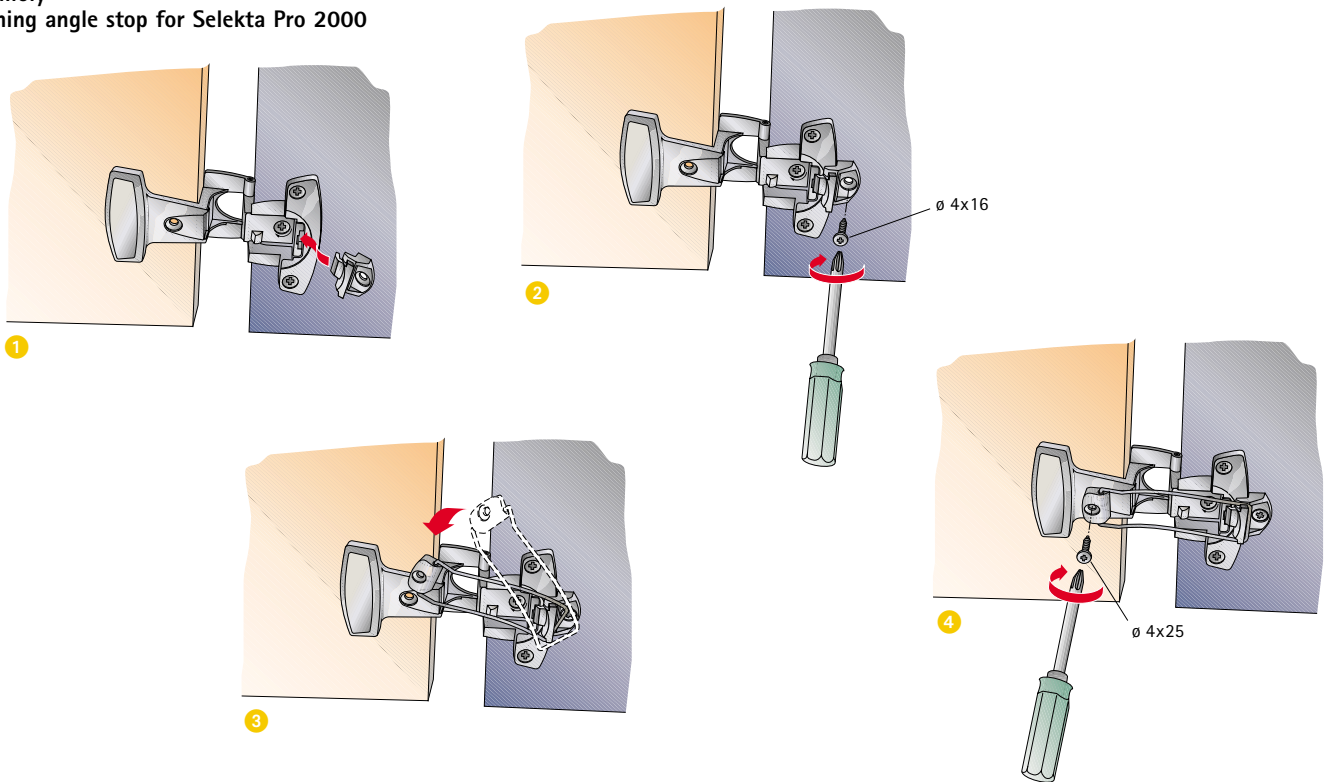

Selekta Pro 2000  
Door buffer  
for drilling diameter 8 mm  
Plastic





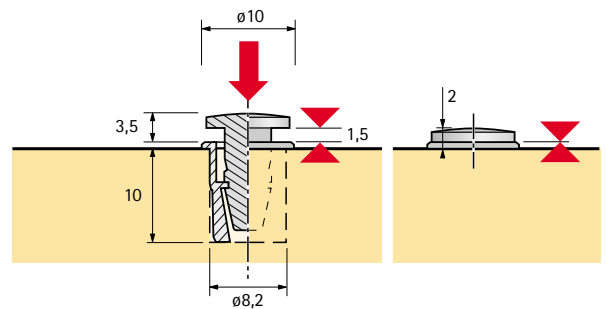





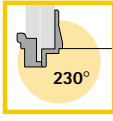
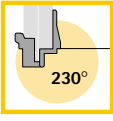
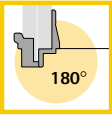

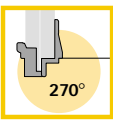

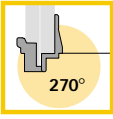

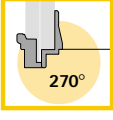
| Article     | Finish                    | Order no. | PU  |
|-------------|---------------------------|-----------|-----|
| Door buffer | white/transparent plastic | 045 151   | 100 |
|             | grey/transparent plastic  | 045 152   | 100 |

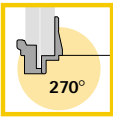

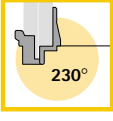
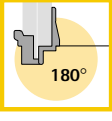
# Selekta Pro 2000 / 2000 E and 2035

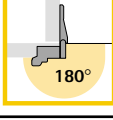
## Programme overview

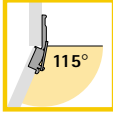
|   | Corner hinge for single cabinet construction  | Corner hinge for cabinet and wall-to-wall design                                    | Twin hinge for cabinet and wall-to-wall design                                      | Reveal mm | Side/door | see page    |
|---|---|---|---|-----------|-----------|-------------|
|    |    |    |    | 8         | 19/19     | 3.174-3.175 |
|    | —   |    | —   | 4         | 19/19     | 3.176-3.177 |
|    | —   |    | —   | 3         | 19/19     | 3.176-3.177 |
|    | —   |    | —   | 4         | 16/16     | 3.178-3.179 |
|  | —   |   | —   | 4         | 16/19     | 3.178-3.179 |
|  | —   |  |  | 6         | 19/19     | 3.180-3.181 |
|  |  | —   | —   | —         | 19/19     | 3.182-3.183 |
|  |  | —   | —   | —         | 19/19     | 3.184-3.185 |

### Number of hinges per door:

Door width, door height, door weight plus material quality of the door are key factors for determining the required number of hinges. In practice, these factors are very variable.

The numbers given in the diagram are for reference only. A trial mounting is recommended if in doubt. For stability, the distance between hinges should be chosen as large as possible.

**X = Distance between two hinges**

(Reference values for 19 mm thick chipboard with a density of 750 kg/m<sup>3</sup>)

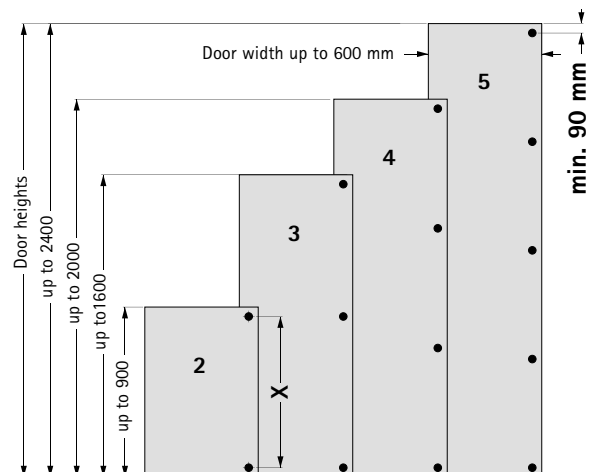

# Selekta Pro 2000

## Single-pivot hinge with snap-on assembly for storage wall and single cabinet construction, 19 mm sides/doors

### Opening angle 180°/230°, hole line 32 mm

For hole line 32 mm, spacing 37 mm

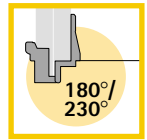
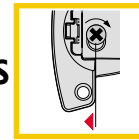

Single pivot hinge with visible knuckle, for storage wall and single cabinet construction, with 19 mm sides/door, precision die-cast zinc  
Opening angle 180°/230, cup diameter 35 mm, door overlay 11 or 5,5 mm. Knuckle diameter 7,0 mm, knuckle length 39 mm.

Separate mounting of cup and hinge arm.

Hinge arm with **expanding dowel** and **pre-mounted pan-head screws**.

Fast-assembly of doors via snap-on attachment, without tools.

High degree of protection against unintentional detachment: The lock can only be released with a screwdriver.

No door protrusion at an opening angle of 180° or greater, leaving interior free for drawers.

Overlay adjustment via eccentric screw -2 mm.

Height adjustment + 2 mm/- 2 mm

by means of eccentric screw in hinge arm.



Fixing countersunk screw  $\varnothing$  3,5 x 16 mm for cup T22, T22/9 and TB22

| Finish        | Order number | PU      |
|---------------|--------------|---------|
| nickel-plated | 071 925      | 200 pcs |

Seleakta Pro 2000 hinge = Hinge arm + cup

#### Hinge version

**Corner hinge for single cabinet construction**  
Door overlay 11 mm  
Opening angle 230°



#### Mounting option

Knuckle flush

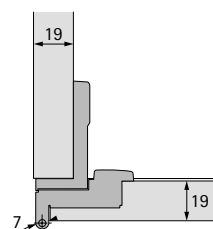

#### Article/order number

Hinge arm (order cups separately, see page 3.175)

| Seleakta Pro 2000 Die-cast zinc with self-closing | PU 50 pcs | Seleakta Pro 2000 Die-cast zinc without self-closing | PU 50 pcs |
|---|-----------|--|-----------|
| nickel-plated                                     | 045 065   | nickel-plated  | 045 057   |

**Corner hinge for storage wall and cabinet construction**  
Door overlay 5,5 mm  
Opening angle 230°



Knuckle central

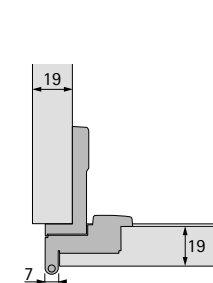

| Seleakta Pro 2000 Die-cast zinc with self-closing | PU 50 pcs | Seleakta Pro 2000 Die-cast zinc without self-closing | PU 50 pcs |
|---|-----------|--|-----------|
| nickel-plated                                     | 045 066   | nickel-plated  | 045 058   |

**Twin hinge storage wall construction**  
Door overlay 5,5 mm  
Opening angle 180°



Knuckle central

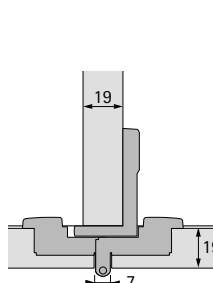

| Seleakta Pro 2000 Die-cast zinc with self-closing | PU 50 pcs | Seleakta Pro 2000 Die-cast zinc without self-closing | PU 50 pcs |
|---|-----------|--|-----------|
| nickel-plated                                     | 045 067   | nickel-plated  | 045 059   |

## Specification

Hettich-Selekta Pro 2000 for storage wall and single cabinet construction with 19 mm sides/doors

Single pivot hinge with snap-on assembly

Overlay and height adjustment via eccentric screw

Hinge arm with expanding dowel and pre-mounted pan-head screws

Hole line 32 mm, opening angle 180°/230°, precision die-cast zinc

### Cup T 22

Screw-on  
Die-cast zinc

### Cup T 23

Press-in  
Die-cast zinc

### Cup T 22/9

Screw-on  
Die-cast zinc

### Cup T 23/9

Press-in  
Die-cast zinc

### Cup TB 22

Screw-on  
Die-cast zinc

### Cup TB 23

Press-in  
Die-cast zinc

| Finish        | Order no. | Finish        | Order no. | Finish        | Order no. | Finish        | Order no. | Finish        | Order no. | Finish        | Order no. |
|---------------|-----------|---------------|-----------|---------------|-----------|---------------|-----------|---------------|-----------|---------------|-----------|
| nickel-plated | 077 734   | nickel-plated | 077 735   | nickel-plated | 077 736   | nickel-plated | 077 887   | nickel-plated | 010 074   | nickel-plated | 077 942   |

### T22 hole dimensions

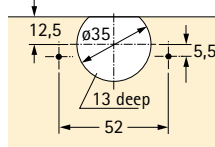

### T23 hole dimensions

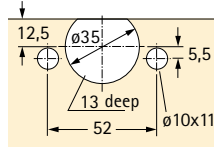

### T22/9 hole dimensions

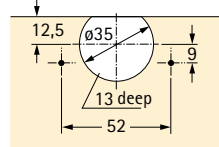

### T23/9 hole dimensions

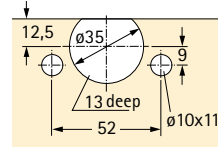

### TB22 hole dimensions

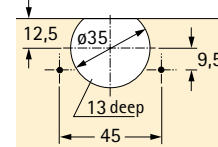

### TB23 hole dimensions

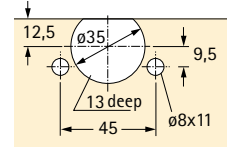

### Mounting example

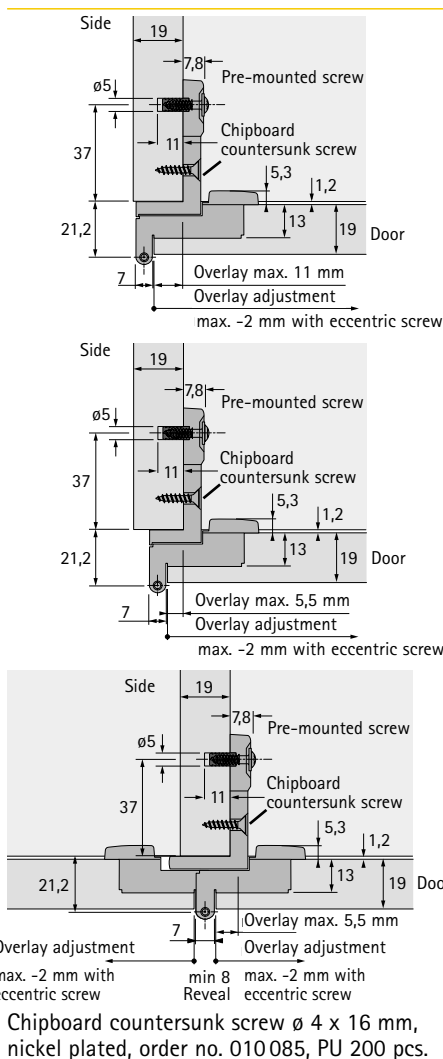

### Accessories

**Cover cap for Selektta Pro 2000**  
Silver-grey plastic  
Order no. 010 067 PU 50 pcs

**Opening angle stop**  
Nickel-plated finish  
PU 50 sets

- 1 set contains:
- Runner clip, screw  $\varnothing$  4 x 16 mm,
  - Wire spring with fastening plate,
  - Screw 4 x 25 mm

| Article                 | Order no. |
|-------------------------|-----------|
| Opening angle stop 90°  | 043 039   |
| Opening angle stop 115° | 043 052   |

### Insertion dies for drilling machine

| Hole dimension | Order no. |
|----------------|-----------|
| T23            | 010 079   |
| T23/9          | 079 240   |
| TB23           | 010 080   |

**Selekta Pro 2000 Door buffer**  
for drilling diameter 8 mm  
Plastic

| Article     | Finish                    | Order no. | PU  |
|-------------|---------------------------|-----------|-----|
| Door buffer | white/transparent plastic | 045 151   | 100 |
|             | grey/transparent plastic  | 045 152   | 100 |

### Door adjustment



**Overlay adjustment**  
Turn eccentric screw (A) to right, the overlay can be reduced max. -2 mm.

**Eccentric height adjustment ( $\pm$  2 mm)**  
Turn eccentric screw (B) to right or left to lower or raise the door height. Then screw in the chipboard countersunk screws (C)  $\varnothing$  4 x 16 mm, order no. 010 085, PU 200 pcs.

### Clothing protection

white plastic  
Order no. 046 847 PU 50



# Selekta Pro 2000

## Single pivot hinge with snap-on assembly

### For single cabinets, 19 mm sides/doors

### Opening angle 270°, hole line 32 mm

For hole line 32 mm,  
spacing 37 mm

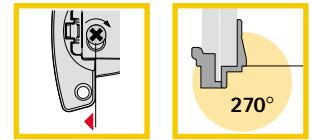

Single pivot hinge with visible knuckle, for cabinet construction and 19 mm sides/doors, precision die-cast zinc

Opening angle 270°, cup diameter 35 mm, door overlay 15 or 16 mm. Knuckle diameter 5,4 mm, knuckle length 39 mm.

Separate mounting of cup and hinge arm.

Hinge arm with **expanding dowel** and **pre-mounted pan-head screws**.

Fast-assembly of doors via snap-on attachment, without tools.

High degree of protection against unintentional detachment: The lock can only be released with a screwdriver.

No door protrusion with 270° opening angle, free interior space for pull out elements.

Overlay adjustment via eccentric screw -2 mm.

Height adjustment + 2 mm/- 2 mm

by means of eccentric screw in hinge arm



Fixing countersunk screw  $\varnothing 3,5 \times 16$  mm  
for cup T22/9 and TB22

| Finish        | Order number | PU      |
|---------------|--------------|---------|
| nickel-plated | 071 925      | 200 pcs |

Selekta Pro 2000  
hinge =  
Hinge arm + cup

#### Hinge version

##### Corner hinge for single cabinet construction

Door overlay 15 mm  
Opening angle 270°



#### Mounting option

Knuckle flush

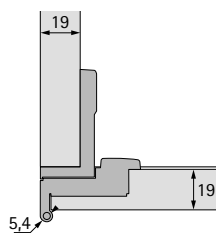

#### Article/order number

Hinge arm (order cups separately, see page 3.177)

| Selekta Pro 2000<br>Die-cast zinc<br>with self-closing | PU 50 pcs | Selekta Pro 2000<br>Die-cast zinc<br>without self-closing | PU 50 pcs |
|--|-----------|---|-----------|
|--|-----------|---|-----------|

|               |         |               |         |
|---------------|---------|---------------|---------|
| nickel-plated | 045 044 | nickel-plated | 045 049 |
|---------------|---------|---------------|---------|

##### Corner hinge for single cabinet construction

Door overlay 16 mm  
Opening angle 270°



Knuckle flush

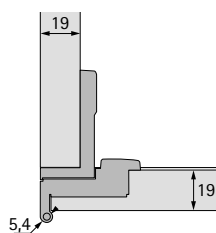

| Selekta Pro 2000<br>Die-cast zinc<br>with self-closing | PU 50 pcs | Selekta Pro 2000<br>Die-cast zinc<br>without self-closing | PU 50 pcs |
|--|-----------|---|-----------|
|--|-----------|---|-----------|

|               |         |               |         |
|---------------|---------|---------------|---------|
| nickel-plated | 045 045 | nickel-plated | 045 051 |
|---------------|---------|---------------|---------|

#### Selekta Pro 2000 Door buffer

for drilling diameter 8 mm  
Plastic



| Article     | Finish                    | Order no. | PU  |
|-------------|---------------------------|-----------|-----|
| Door buffer | white/transparent plastic | 045 151   | 100 |
|             | grey/transparent plastic  | 045 152   | 100 |

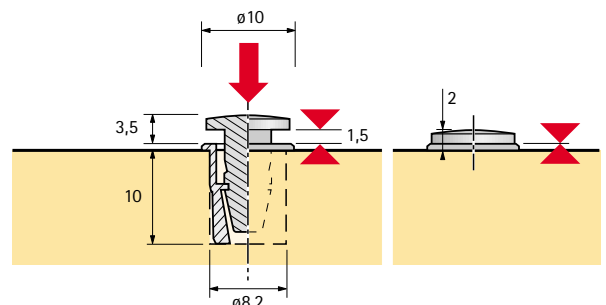

## Specification

Hettich-Selekta Pro 2000 for cabinet construction and 19 mm sides/doors

Single pivot hinge with snap-on assembly

Overlay and height adjustment via eccentric screw

Hinge arm with expanding dowel and pre-mounted pan-head screws

Hole line 32 mm, opening angle 270°, precision die-cast zinc

### Cup T 22/9

Screw-on  
Die-cast zinc

### Cup T 23/9

Press-in  
Die-cast zinc

### Cup TB 22

Screw-on  
Die-cast zinc

### Cup TB 23

Press-in  
Die-cast zinc

| Finish        | Order no. | Finish        | Order no. | Finish        | Order no. | Finish        | Order no. |
|---------------|-----------|---------------|-----------|---------------|-----------|---------------|-----------|
| nickel-plated | 077 736   | nickel-plated | 077 887   | nickel-plated | 010 074   | nickel-plated | 077 942   |

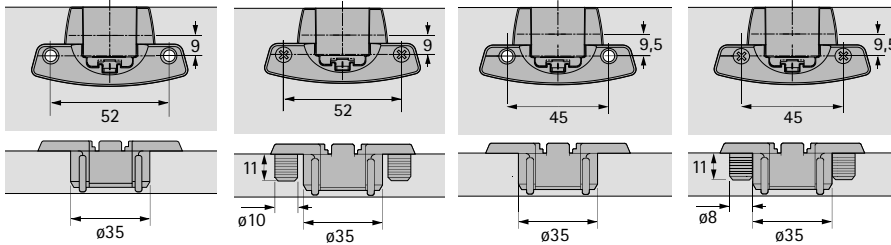

### T22/9 hole dimensions

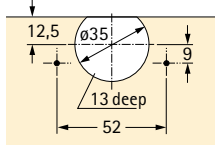

### T23/9 hole dimensions

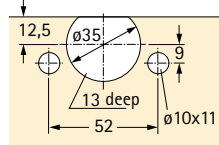

### TB22 hole dimensions

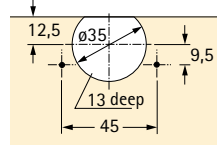

### TB23 hole dimensions

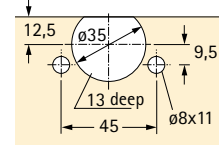

### Mounting example

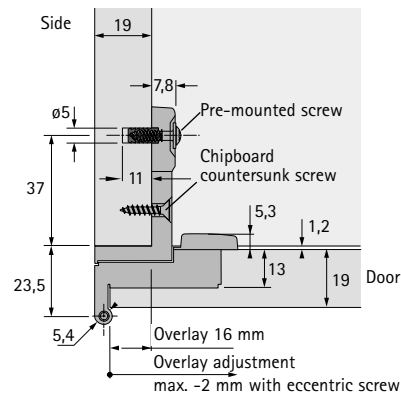
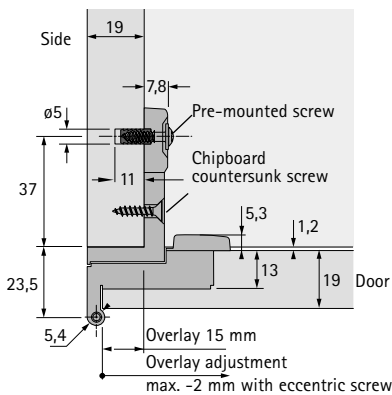

Chipboard countersunk screw  $\varnothing$  4 x 16 mm, nickel plated, order no. 010 085, PU 200 pcs.

### Accessories

#### Cover cap for Seleakta Pro 2000

Silver-grey plastic

Order no. 010 067 PU 50 pcs



#### Opening angle stop

Nickel-plated finish  
PU 50 sets



1 set contains:

- Runner clip, screw 4 x 16 mm,
- Wire spring with fastening plate,
- Screw 4 x 25 mm

| Article                 | Order no. |
|-------------------------|-----------|
| Opening angle stop 90°  | 043 039   |
| Opening angle stop 115° | 043 052   |

#### Insertion dies for drilling machine

| Hole dimension | Order no. |
|----------------|-----------|
| T23/9          | 079 240   |
| TB23           | 010 080   |

### Door adjustment



#### Overlay adjustment

Turn eccentric screw (A) to right, the overlay can be reduced max. -2 mm.

#### Eccentric height adjustment ( $\pm$ 2 mm)

Turn eccentric screw (B) to right or left to lower or raise the door height. Then screw in the **chipboard countersunk screws** (C)  $\varnothing$  4 x 16 mm, order no. 010085, PU 200 pcs.

#### Clothing protection

white plastic

Order no. PU  
046 847 50

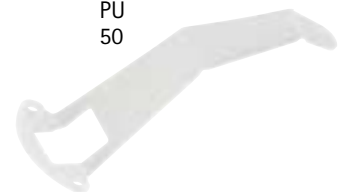

# Selekta Pro 2000

## Single pivot hinge with snap-on assembly for single cabinet construction, 16 mm sides and 16/19 mm doors

### Opening angle 270°, hole line 32 mm

For hole line 32 mm, spacing 37 mm

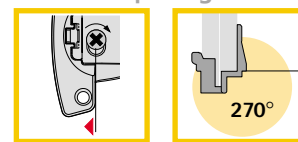

Single pivot hinge with visible knuckle, for cabinet construction, 16 mm sides and 16/19 mm doors, precision die-cast zinc

Opening angle 270°, cup diameter 35 mm, door overlay 12 mm, knuckle diameter 5,4 mm, knuckle length 39 mm.

Separate mounting of cup and hinge arm.

Hinge arm with **expanding dowel** and **pre-mounted pan-head screws**.

Fast-assembly of doors via snap-on attachment, without tools.

High degree of protection against unintentional detachment: The lock can only be released with a screwdriver.

No door protrusion with 270° opening angle, free interior space for pull out elements.

Overlay adjustment via eccentric screw -2 mm.

Height adjustment + 2 mm/- 2 mm

by means of eccentric screw in hinge arm



Fixing countersunk screw  $\varnothing 3,5 \times 16$  mm for cup T 22, T 22/9 and TB 22

| Finish        | Order number | PU      |
|---------------|--------------|---------|
| nickel-plated | 071 925      | 200 pcs |

Selekta Pro 2000 hinge = Hinge arm + cup

#### Hinge version

Corner hinge for single cabinet construction  
Door overlay 12 mm  
Opening angle 270°



#### Mounting option

Knuckle flush

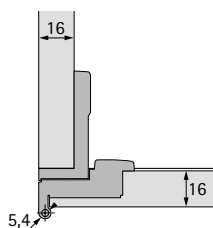

#### Article/order number

Hinge arm (order cups separately, see page 3.179)

| Selekta Pro 2000 Die-cast zinc with self-closing | PU 50 pcs | Selekta Pro 2000 Die-cast zinc without self-closing | PU 50 pcs |
|--|-----------|---|-----------|
| nickel-plated                                    | 045 046   | nickel-plated                                       | 045 052   |

Corner hinge for single cabinet construction  
Door overlay 12 mm  
Opening angle 270°



Knuckle flush

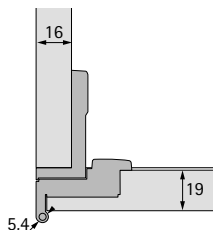

| Selekta Pro 2000 Die-cast zinc with self-closing | PU 50 pcs | Selekta Pro 2000 Die-cast zinc without self-closing | PU 50 pcs |
|--|-----------|---|-----------|
| nickel-plated                                    | 045 047   | nickel-plated                                       | 045 053   |

Selekta Pro 2000 Door buffer  
for drilling diameter 8 mm  
Plastic



| Article     | Finish                    | Order no. | PU  |
|-------------|---------------------------|-----------|-----|
| Door buffer | white/transparent plastic | 045 151   | 100 |
|             | grey/transparent plastic  | 045 152   | 100 |

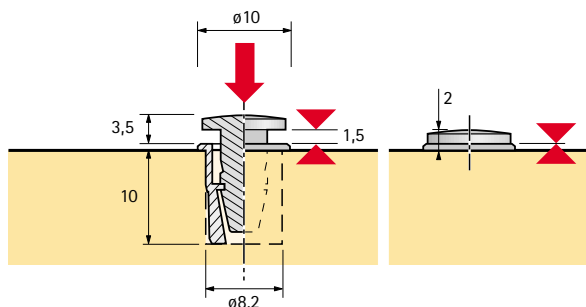

## Specification

Hettich-Selekta Pro 2000 for cabinet construction 16 mm sides and 16/19 mm doors

Single pivot hinge with snap-on assembly

Overlay and height adjustment via eccentric screw

Hinge arm with expanding dowel and pre-mounted pan-head screws

Hole line 32 mm, opening angle 270°, precision die-cast zinc

**Cup T 22**  
Screw-on  
Die-cast zinc

**Cup T 23**  
Press-in  
Die-cast zinc

**Cup T 22/9**  
Screw-on  
Die-cast zinc

**Cup T 23/9**  
Press-in  
Die-cast zinc

**Cup TB 22**  
Screw-on  
Die-cast zinc

**Cup TB 23**  
Press-in  
Die-cast zinc

**Finish**    **Order no.**  
nickel-plated 077 734

**Finish**    **Order no.**  
nickel-plated 077 735

**Finish**    **Order no.**  
nickel-plated 077 736

**Finish**    **Order no.**  
nickel-plated 077 887

**Finish**    **Order no.**  
nickel-plated 010 074

**Finish**    **Order no.**  
nickel-plated 077 942

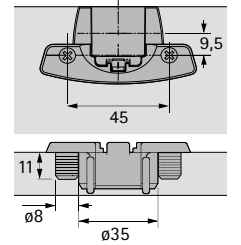
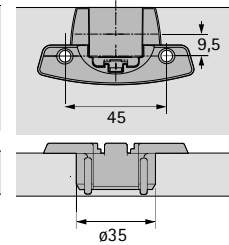
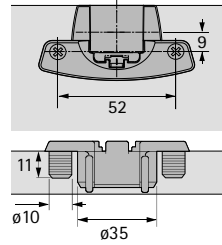
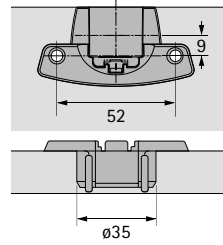
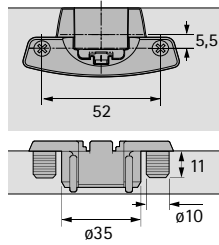
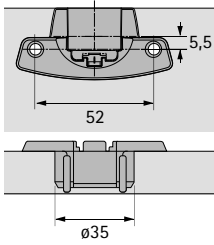

**T22 hole dimensions**

**T23 hole dimensions**

**T22/9 hole dimensions**

**T23/9 hole dimensions**

**TB22 hole dimensions**

**TB23 hole dimensions**

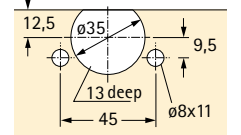
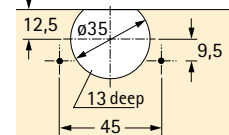
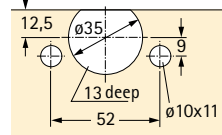
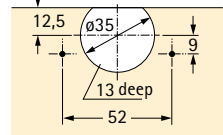
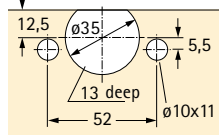
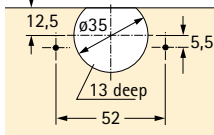

### Mounting example

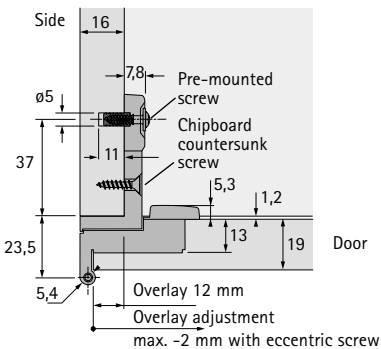
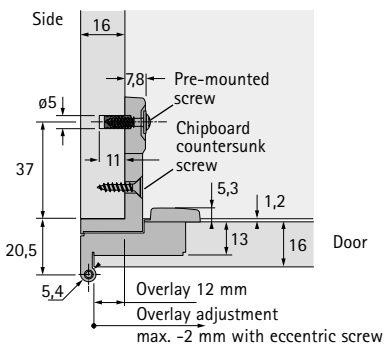

Chipboard countersunk screw  $\varnothing$  4 x 16 mm, nickel plated, order no. 010 085, PU 200 pcs.

### Accessories

#### Cover cap for Selektta Pro 2000

Silver-grey plastic

Order no. 010 067      PU 50 pcs



#### Opening angle stop

Nickel-plated finish  
PU 50 sets



1 set contains:

- Runner clip, screw 4 x 16 mm,
- Wire spring with fastening plate,
- Screw 4 x 25 mm

| Article                 | Order no. |
|-------------------------|-----------|
| Opening angle stop 90°  | 043 039   |
| Opening angle stop 115° | 043 052   |

#### Insertion dies for drilling machine

| Hole dimension | Order no. |
|----------------|-----------|
| T23            | 010 079   |
| T23/9          | 079 240   |
| TB23           | 010 080   |

### Door adjustment



#### Overlay adjustment

Turn eccentric screw (A) to right, the overlay can be reduced max. -2 mm.

#### Height adjustment ( $\pm$ 2 mm)

Turn eccentric screw (B) to right or left to lower or raise the door height. Then screw in the **chipboard countersunk screws (C)**  $\varnothing$  4 x 16 mm, order no. 010 085, PU 200 pcs.

#### Clothing protection

white plastic

Order no.      PU  
046 847      50



# Selekta Pro 2000

## Single-pivot hinge with snap-on assembly for storage wall and single cabinet construction, 19 mm sides/doors

### Opening angle 180°/230°, hole line 32 mm

For hole line 32 mm,  
spacing 37 mm

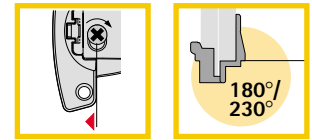

Single pivot hinge with visible knuckle, for storage wall and single cabinet construction, with 19 mm sides/door, precision die-cast zinc

Opening angle 180°/230°, cup diameter 35 mm, door overlay 6,5 mm.  
Knuckle diameter 5,4 mm, knuckle length 39 mm.

Separate mounting of cup and hinge arm.

Hinge arm with **expanding dowel** and **pre-mounted pan-head screws**.

Fast-assembly of doors via snap-on attachment, without tools.

High degree of protection against unintentional detachment: The lock can only be released with a screwdriver.

No door protrusion with 180° opening angle, free interior space for pull out elements.

Overlay adjustment via eccentric screw -2 mm.

Height adjustment + 2 mm/- 2 mm

by means of eccentric screw in hinge arm



Fixing countersunk screw  $\varnothing$  3,5 x 16 mm  
for cup T 22, T 22/9 and TB 22

| Finish        | Order number | PU      |
|---------------|--------------|---------|
| nickel-plated | 071 925      | 200 pcs |

Seleakta Pro 2000  
hinge =  
Hinge arm + cup

#### Hinge version

**Corner hinge for storage wall and cabinet construction**  
Door overlay 6,5 mm  
Opening angle 230°



#### Mounting option

Knuckle central

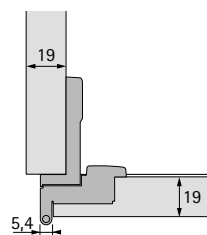

#### Article/order number

Hinge arm (order cups separately, see page 3.181)

| Seleakta Pro 2000<br>Die-cast zinc<br>with self-closing | PU 50 pcs | Seleakta Pro 2000<br>Die-cast zinc<br>without self-closing | PU 50 pcs |
|---|-----------|--|-----------|
| nickel-plated   | 045 048   | nickel-plated  | 045 054   |

**Twin hinge storage wall construction**  
Door overlay 6,5 mm  
Opening angle 180°



Knuckle central

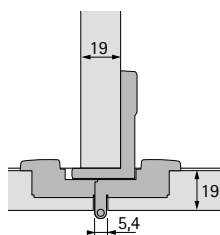

| Seleakta Pro 2000<br>Die-cast zinc<br>with self-closing | PU 50 pcs | Seleakta Pro 2000<br>Die-cast zinc<br>without self-closing | PU 50 pcs |
|---|-----------|--|-----------|
| nickel-plated   | 045 063   | nickel-plated  | 045 055   |

**Seleakta Pro 2000  
Door buffer**  
for drilling diameter 8 mm  
Plastic



| Article     | Finish                    | Order no. | PU  |
|-------------|---------------------------|-----------|-----|
| Door buffer | white/transparent plastic | 045 151   | 100 |
|             | grey/transparent plastic  | 045 152   | 100 |

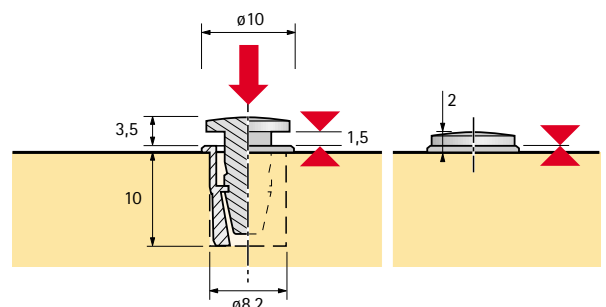

## Specification

Hettich-Selekta Pro 2000 for storage wall and single cabinet construction with 19 mm sides/doors

Single pivot hinge with snap-on assembly

Overlay and height adjustment via eccentric screw

Hinge arm with expanding dowel and pre-mounted pan-head screws

Hole line 32 mm, opening angle 180°/230°, precision die-cast zinc

**Cup T 22**  
Screw-on  
Die-cast zinc

**Cup T 23**  
Press-in  
Die-cast zinc

**Cup T 22/9**  
Screw-on  
Die-cast zinc

**Cup T 23/9**  
Press-in  
Die-cast zinc

**Cup TB 22**  
Screw-on  
Die-cast zinc

**Cup TB 23**  
Press-in  
Die-cast zinc

**Finish**    **Order no.**  
nickel-plated 077 734

**Finish**    **Order no.**  
nickel-plated 077 735

**Finish**    **Order no.**  
nickel-plated 077 736

**Finish**    **Order no.**  
nickel-plated 077 887

**Finish**    **Order no.**  
nickel-plated 010 074

**Finish**    **Order no.**  
nickel-plated 077 942

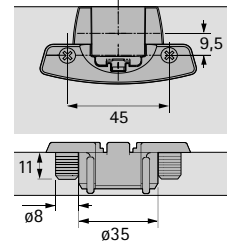
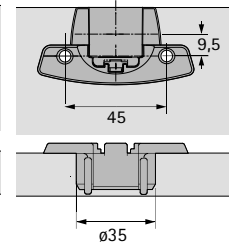
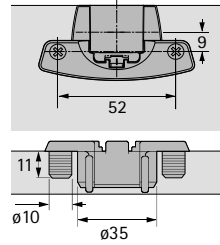
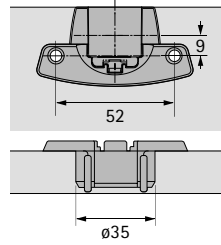
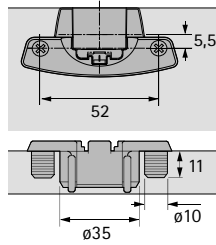
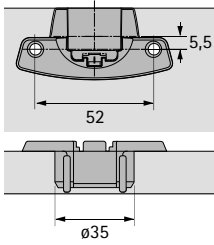

### T22 hole dimensions

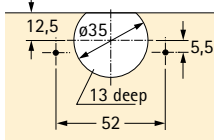

### T23 hole dimensions

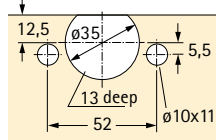

### T22/9 hole dimensions

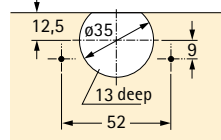

### T23/9 hole dimensions

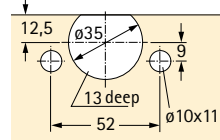

### TB22 hole dimensions

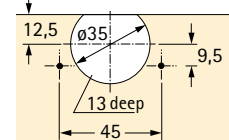

### TB23 hole dimensions

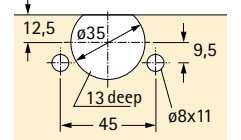

### Mounting example

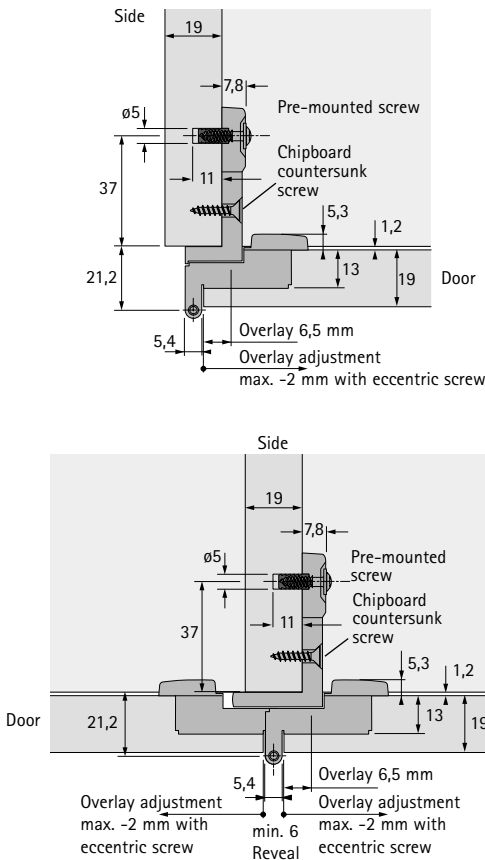

Chipboard countersunk screw  $\varnothing$  4 x 16 mm, nickel plated, order no. 010 085, PU 200 pcs.

### Accessories

#### Cover cap for Selektta Pro 2000

Silver-grey plastic

Order no. 010 067    PU 50 pcs



#### Opening angle stop

Nickel-plated finish

PU 50 sets



1 set contains:

- Runner clip, screw 4 x 16 mm,
- Wire spring with fastening plate,
- Screw 4 x 25 mm

| Article                 | Order no. |
|-------------------------|-----------|
| Opening angle stop 90°  | 043 039   |
| Opening angle stop 115° | 043 052   |

#### Insertion dies for drilling machine

| Hole dimension | Order no. |
|----------------|-----------|
| T23            | 010 079   |
| T23/9          | 079 240   |
| TB23           | 010 080   |

### Door adjustment



#### Overlay adjustment

Turn eccentric screw (A) to right, the overlay can be reduced max. -2 mm.

#### Eccentric height adjustment ( $\pm$ 2 mm)

Turn eccentric screw (B) to right or left to lower or raise the door height.

Then screw in the **chipboard countersunk screws (C)**  $\varnothing$  4 x 16 mm, order no. 010 085, PU 200 pcs.

#### Clothing protection

white plastic

Order no. 046 847    PU 50

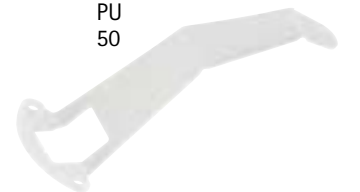

# Selekta Pro 2000 E

## Single-pivot hinge with snap-on assembly for inset doors single cabinets

### 19 mm sides/doors, opening angle 180°

For hole line 32 mm

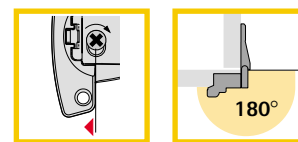

Single pivot hinge with visible knuckle for inset doors, for cabinet construction and 19 mm sides/doors, hole line 32 mm  
Precision zinc diecast

Opening angle 180°, cup diameter 35 mm.

Knuckle diameter 5,4 mm, knuckle length 39 mm.

Separate mounting of cup and hinge arm.

Hinge arm with **expanding dowel** and **pre-mounted pan-head screws**.

Fast-assembly of doors via snap-on attachment, without tools.

High degree of protection against unintentional detachment: The lock can only be released with a screwdriver.

No door protrusion with 180° opening angle, free interior space for pull out elements.

Side adjustment via eccentric screw -2 mm.

Height adjustment + 2 mm/- 2 mm

by means of eccentric screw in hinge arm



Fixing countersunk screw  $\varnothing 3,5 \times 16$  mm for cup T 22/9 and TB 22

| Finish        | Order number | PU      |
|---------------|--------------|---------|
| nickel-plated | 071 925      | 200 pcs |

Seleakta Pro 2000 hinge = Hinge arm + cup

#### Hinge version

Corner hinge for single cabinet construction  
Opening angle 180°



#### Mounting option

Inset

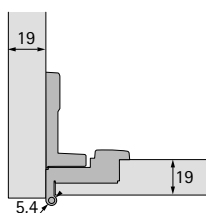

#### Article/order number

Hinge arm (order cups separately, see page 3.183)

| Seleakta Pro 2000 Die-cast zinc with self-closing | PU 50 pcs | Seleakta Pro 2000 Die-cast zinc without self-closing | PU 50 pcs |
|---|-----------|--|-----------|
|---|-----------|--|-----------|

|               |         |               |         |
|---------------|---------|---------------|---------|
| nickel-plated | 045 064 | nickel-plated | 045 056 |
|---------------|---------|---------------|---------|

#### Seleakta Pro 2000 Door buffer

for drilling diameter 8 mm  
Plastic



| Article     | Finish                    | Order no. | PU  |
|-------------|---------------------------|-----------|-----|
| Door buffer | white/transparent plastic | 045 151   | 100 |
|             | grey/transparent plastic  | 045 152   | 100 |

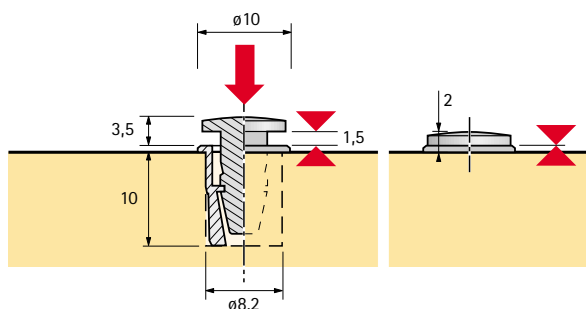

## Specification

Hettich-Selekta Pro 2000 E for inset doors, cabinet construction with 19 mm sides/doors

Single pivot hinge with snap-on assembly

Side and height adjustment by means of eccentric screw

Hinge arm with expanding dowel and pre-mounted pan-head screws

Hole line 32 mm, opening angle 180°, precision die-cast zinc

| Cup T 22                   |                  | Cup T 23                   |                  | Cup T 22/9                   |                  | Cup T 23/9                   |                  | Cup TB 22                   |                  | Cup TB 23                   |                  |
|----------------------------|------------------|----------------------------|------------------|------------------------------|------------------|------------------------------|------------------|-----------------------------|------------------|-----------------------------|------------------|
| Screw-on                   |                  | Press-in                   |                  | Screw-on                     |                  | Press-in                     |                  | Screw-on                    |                  | Press-in                    |                  |
| Die-cast zinc              |                  | Die-cast zinc              |                  | Die-cast zinc                |                  | Die-cast zinc                |                  | Die-cast zinc               |                  | Die-cast zinc               |                  |
| <b>Finish</b>              | <b>Order no.</b> | <b>Finish</b>              | <b>Order no.</b> | <b>Finish</b>                | <b>Order no.</b> | <b>Finish</b>                | <b>Order no.</b> | <b>Finish</b>               | <b>Order no.</b> | <b>Finish</b>               | <b>Order no.</b> |
| nickel-plated              | 077 734          | nickel-plated              | 077 735          | nickel-plated                | 077 736          | nickel-plated                | 077 887          | nickel-plated               | 010 074          | nickel-plated               | 077 942          |
|                            |                  |                            |                  |                              |                  |                              |                  |                             |                  |                             |                  |
|                            |                  |                            |                  |                              |                  |                              |                  |                             |                  |                             |                  |
| <b>T22 hole dimensions</b> |                  | <b>T23 hole dimensions</b> |                  | <b>T22/9 hole dimensions</b> |                  | <b>T23/9 hole dimensions</b> |                  | <b>TB22 hole dimensions</b> |                  | <b>TB23 hole dimensions</b> |                  |
|                            |                  |                            |                  |                              |                  |                              |                  |                             |                  |                             |                  |

### Mounting example

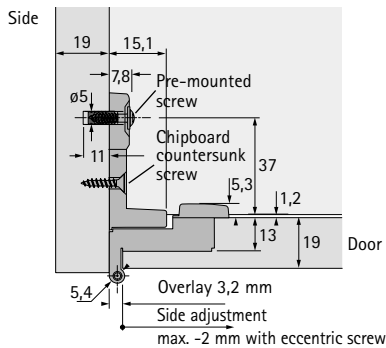

Chipboard countersunk screw  $\varnothing 4 \times 16$  mm, nickel plated, order no. 010 085, PU 200 pcs.

### Accessories

#### Cover cap for Selekta Pro 2000 E

Silver-grey plastic

Order no. 010 067

PU 50 pcs



#### Insertion dies for drilling machine

Hole dimension      Order no.

T23                      010 079

T23/9                  079 240

TB 23                  010 080

### Door adjustment



#### Overlay adjustment

Turn eccentric screw (A) to right, the overlay can be reduced max. -2 mm.

#### Eccentric height adjustment ( $\pm 2$ mm)

Turn eccentric screw (B) to right or left to lower or raise the door height.

Then screw in the **chipboard countersunk screws** (C)  $\varnothing 4 \times 16$  mm, order no. 010 085, PU 200 pcs.

#### Clothing protection

white plastic

Order no.

PU

046 847

50



# Selekta Pro 2035

## Single pivot hinge with snap-on assembly, not visible from front, for single cabinet construction, with 19 mm sides/doors, opening angle 115°

For hole line 32 mm, spacing 37 mm

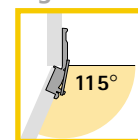

Single pivot hinge with snap-on assembly, not visible from front, for cabinet construction with 19 mm sides and doors, Precision zinc diecast

Opening angle 115°, door overlay 15 mm, cup diameter 35 mm.

Separate mounting of cup and hinge arm.

Hinge arm with **expanding dowel** and **pre-mounted pan-head screws**.

Fast-assembly of doors via snap-on attachment, without tools.

High degree of protection against unintentional detachment: The lock can only be released with a screwdriver.

No door protrusion with 90° opening angle, free interior space for pull out elements.

Overlay adjustment via eccentric screw -2 mm.

Height adjustment via hinge  $\pm 2$  mm.



Fixing countersunk screw  $\varnothing 3,5 \times 16$  mm for cup T 22/9 and TB 22

| Finish        | Order number | PU      |
|---------------|--------------|---------|
| nickel-plated | 071 925      | 200 pcs |

Selekta Pro 2000 hinge = Hinge arm + cup

### Hinge version

Corner hinge for single cabinet construction

Door overlay 15 mm  
Opening angle 115°



### Mounting option

Without knuckle

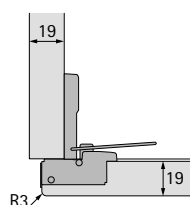

Twin-mounting without knuckle

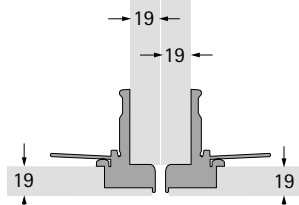

### Article/order number

Hinge arm (order cups separately, see page 3.185)

Selekta Pro 2000 Die-cast zinc with self-closing

PU 50 pcs

nickel-plated 046 067

### Selekta Pro 2000 Door buffer

for drilling diameter 8 mm  
Plastic



| Article     | Finish                    | Order no. | PU  |
|-------------|---------------------------|-----------|-----|
| Door buffer | white/transparent plastic | 045 151   | 100 |
|             | grey/transparent plastic  | 045 152   | 100 |

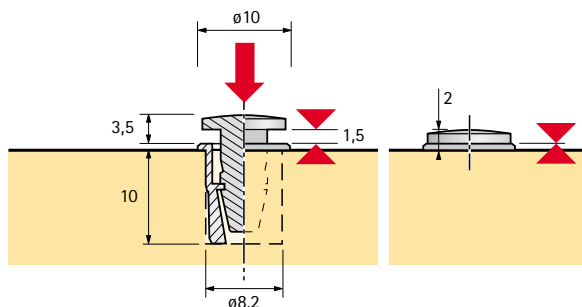

### Mounting example

The caps pre-mounted on the front should be removed for additional profile or roller design.

Reduce overlay by 0,3 mm at the overlay adjustment screw to allow the door to open smoothly.

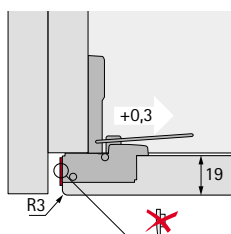

The caps pre-mounted on the front should be removed on directly adjacent units.

Reduce overlay by 0,3 mm at the overlay adjustment screw to allow the door to open smoothly.

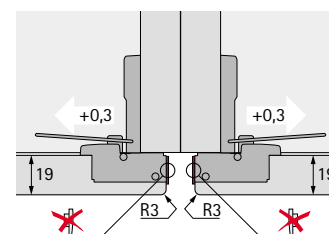

## Specification

Hettich Selektä Pro 2035 not visible from front, for single cabinet construction, with 19 mm sides/doors,

Single pivot hinge with snap-on assembly

Overlay adjustment by means of adjustment screw

Hinge arm with expanding dowel and pre-mounted pan-head screws

Hole line 32 mm, opening angle 115°, precision die-cast zinc

### Cup T 22/9

Screw-on  
Die-cast zinc

### Cup T 23/9

Press-in  
Die-cast zinc

### Cup TB 22

Screw-on  
Die-cast zinc

### Cup TB 23

Press-in  
Die-cast zinc

| Finish        | Order no. | Finish        | Order no. | Finish        | Order no. | Finish        | Order no. |
|---------------|-----------|---------------|-----------|---------------|-----------|---------------|-----------|
| nickel plated | 077 736   | nickel-plated | 077 887   | nickel-plated | 010 074   | nickel-plated | 077 942   |

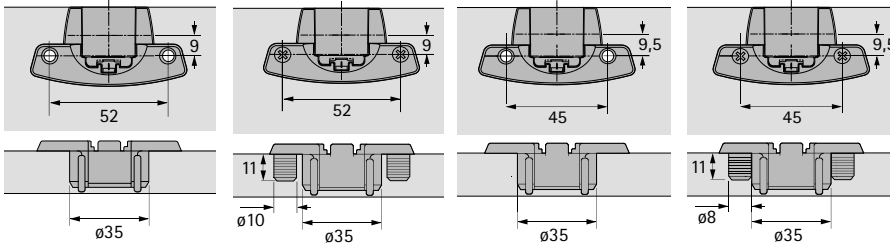

### Hole dimension T 22/9

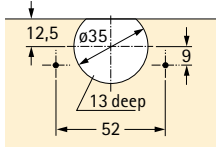

### Hole dimension T 23/9

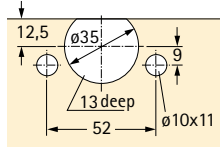

### Hole dimension TB 22

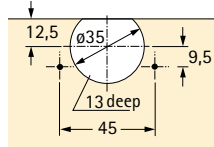

### Hole dimension TB 23

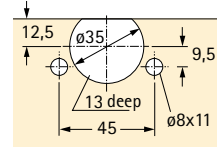

### Mounting example

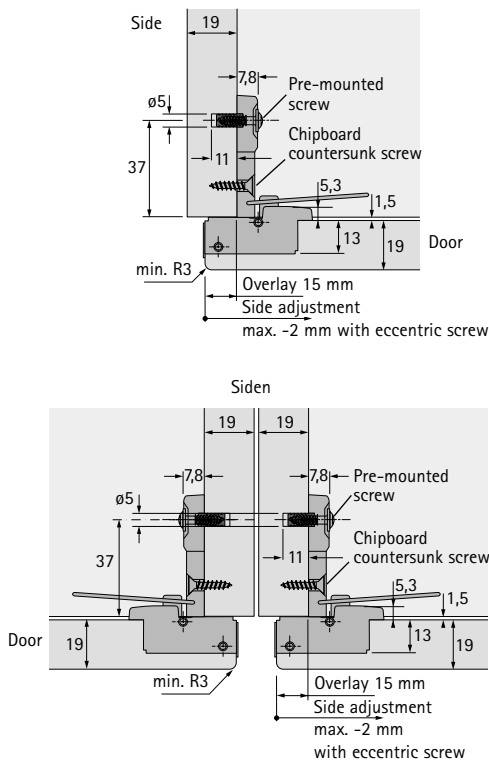

Chipboard countersunk screw  $\varnothing$  3,5 x 20 mm, nickel plated, order no. 071924, PU 200 pcs.

### Accessories

#### Cover cap for Selektä Pro 2000

Silver-grey plastic

Order no. 010 067

PU 50 pcs



#### Insertion dies for drilling machine

Hole pattern

Order no.

T23/9

079 240

TB23

010 080

### Door adjustment



#### Overlay adjustment

Unscrew fixing screw (B). Screw in adjustment screw (A), the door overlay can be reduced by up to 2 mm. Overlay adjustment is possible without complete removal of the fixing screw.

#### Eccentric height adjustment ( $\varnothing$ 2 mm)

Turn eccentric screw (B) to right or left to lower or raise the door height.

Then screw in the **chipboard countersunk screws** (C)  $\varnothing$ 3,5 x 20 mm, order no. 071924, PU 200 pcs.

# Glass door cover cap for Selektapro 2000



## Decorative cap Selektapro 2000 for glass doors Precision die-cast zinc

The hinges Selektapro 2000 can be used as glass door hinge with these cover caps.

Each hinge requires a cut drilling for the hinge cup and two drillings for the fixing screws.

Washers and bushes in transparent plastic protect the glass door and ensure that the hinges are securely mounted on the glass door.

Glass thickness 5 - 6 mm



Only for use with Selektapro 2000 hinges.  
Fixing with countersunk screws M5

| Article/Finish   | Order number | PU |
|--|--------------|----|
| Cover caps for Selektapro 2000 T22 die-cast zinc nickel-plated   | 077 943      | 50 |
| Cover caps for Selektapro 2000 T22/9 die-cast zinc nickel-plated | 077 944      | 50 |
| Cover caps for Selektapro 2000 TB 22 die-cast zinc nickel-plated | 010 075      | 50 |

### Mounting example

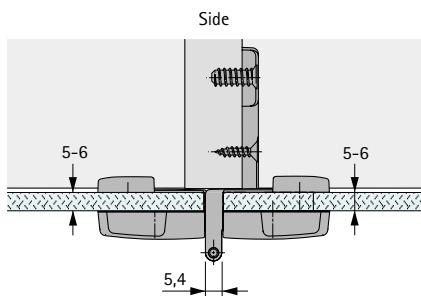
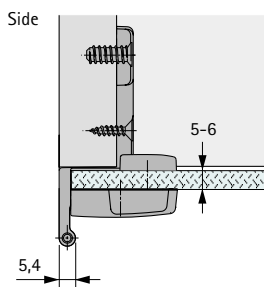

### Hole dimension glass door for cup T22

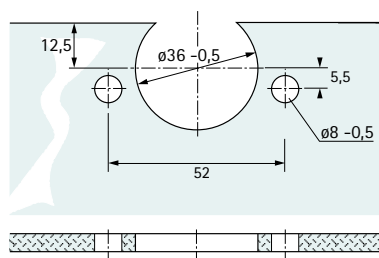

### Hole dimension glass door for cup T22/9

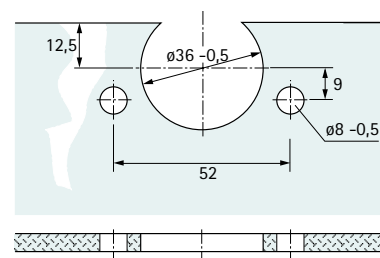

### Hole dimension glass door for cup TB 22

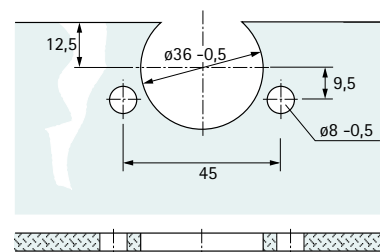

# Selekta 4



3

Single pivot hinge for  
office and commercial furniture

# Selekta 4

## Single pivot hinge with slide-on assembly

### Opening angle 180° for 19 mm side panels

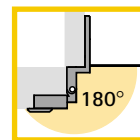

#### Selekta 4

Single pivot hinge for office and commercial furniture.

Precision die-cast zinc

Opening angle 180°, for 19 mm sides and 16-21 mm door thicknesses.

Height adjustable via expanding socket with fixed centre position.

Side adjustment between cup and hinge arm.

Cup and hinge arm can be mounted separately.

In storage wall construction, the knuckle sits centrally on the 19 mm panel ends. Knuckle length 24 mm.

Corner hinge knuckles can be recessed into the door edge.

Accessory: Cover plate for recessed knuckles

Opening angle stop (at the same time clothing protection)



For cover caps for glass doors, see page 3.190

Fixing countersunk screw  $\varnothing 3,5 \times 16$  mm, nickel-plated

for cup T22, order no. 071 925, PU 200

#### Cup version

##### Cup T22

Screw-on  
Nickel-plated

##### Cup T23

Press-in  
Nickel-plated

3

#### Hinge version

Door overlay 6 mm



#### Mounting option

Knuckle central

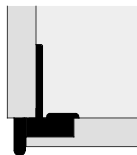

#### Article/order number

##### Selekta 4

- with self-closing
- without self-closing

Packaging unit 50 pcs

Selekta 4-T22  
**042 366**

Selekta 4-T22  
**042 364**

Selekta 4-T23  
**042 367**

Selekta 4-T23  
**042 365**

Door overlay 11 mm



Knuckle flush

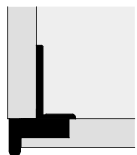

##### Selekta 4

- with self-closing
- without self-closing

Packaging unit 50 pcs

Selekta 4-T22  
**042 382**

Selekta 4-T22  
**042 380**

Selekta 4-T23  
**042 383**

Selekta 4-T23  
**042 381**

Door overlay 6 mm



Knuckle central



##### Selekta 4

- with self-closing
- without self-closing

Packaging unit 50 pcs

Selekta 4-T22  
**042 374**

Selekta 4-T22  
**042 372**

Selekta 4-T23  
**042 375**

Selekta 4-T23  
**042 373**

## Specification

Hettich-Selekta 4 for 19 mm side panels, door thickness 16-21 mm  
 Single pivot hinge with security feature  
 Height adjustment with expanding socket  
 Fixed centre position  
 Precision die-cast zinc

### Hole pattern door for Cup T 22

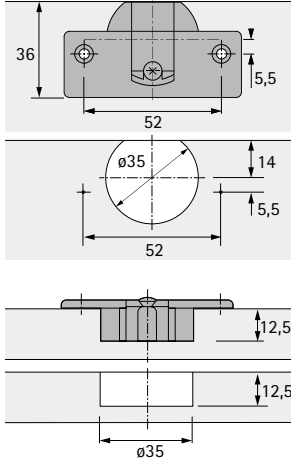

### Hole pattern door for Cup T 23

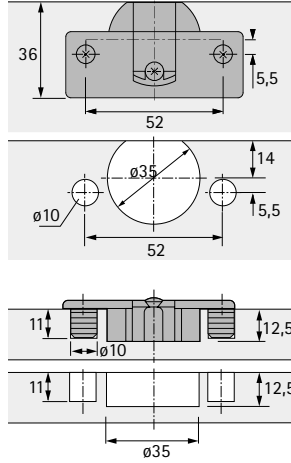

### Hole pattern side

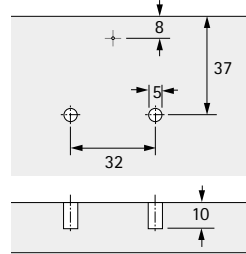

### No door protrusion

free space for internal pull out components

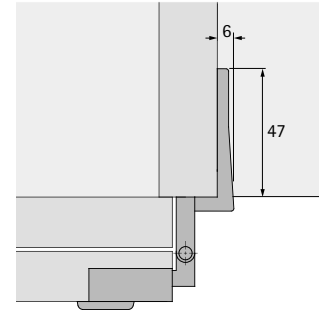

### Mounting example

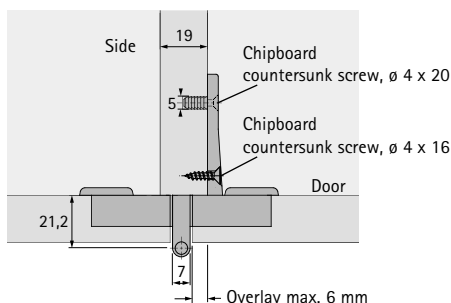
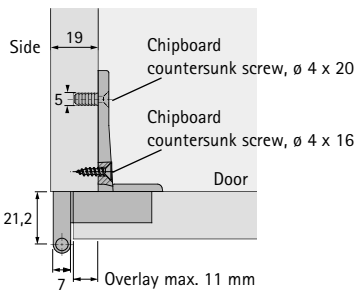
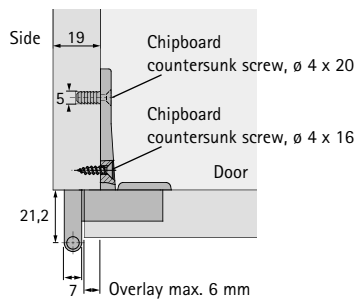

### Accessories

#### Opening angle stop for hinge with 6 mm door overlay Nickel-plated finish



| Opening angle | Order no. | PU     |
|---------------|-----------|--------|
| 90°           | 042 384   | 50 pcs |
| 135°          | 042 385   | 50 pcs |

When used with Selektta 4-T23 use longer fixing screws  
 Order no. 072 995 PU 200 pcs

#### Cover plate for corner hinge with recessed knuckle

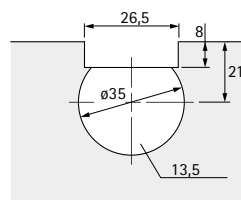

| Finish        | Order no. | PU     |
|---------------|-----------|--------|
| nickel-plated | 031 167   | 50 pcs |

### Door adjustment

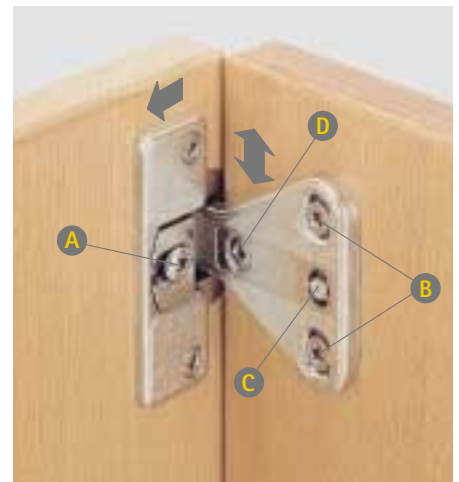

#### Overlay adjustment

Unscrew fixing screw (A).  
 When the door is laterally adjusted, the door overlay can be reduced by up to 4 mm.

#### Height adjustment

Unscrew fixing screws (B).  
 Detach centre stop (C) with screwdriver, adjust the height of the door and tighten the fixing screws (B).  
 Then screw in the front fixing screw.  
 Then screw in the chipboard countersunk screws (D)  $\varnothing$  4 x 16 mm, order no. 010 085, PU 200 pcs.

Chipboard countersunk screw  $\varnothing$  4 x 16 mm, nickel-plated, order no. 010 085, PU 200  
 Chipboard countersunk screw  $\varnothing$  4 x 20 mm, nickel-plated, order no. 046 638, PU 200

# Glass door-cover cap for Selektta 4

3



## Glass door-cover cap for Selektta 4 Precision die-cast zinc

The Selektta 4 hinges can be used as glass door hinges with these cover caps.

Each hinge requires a cut drilling for the hinge cup and two drillings for the fixing screws.

Washers and bushes in transparent plastic protect the glass door and ensure that the hinges are securely mounted.

Glass thickness 5 - 6 mm

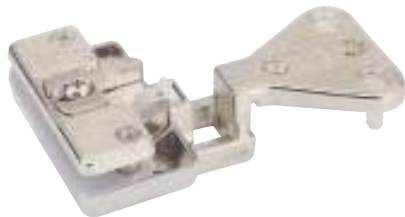

Only for use with the hinge Selektta 4.  
Fixing with countersunk screws M5

| Article/Finish   | Order no. | PU     |
|--|-----------|--------|
| Glass door cover cap for Selektta 4<br>Nickel-plated die-cast zinc | 042 355   | 50 pcs |

### Mounting example

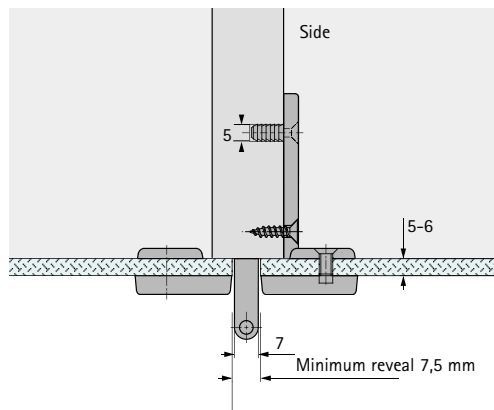
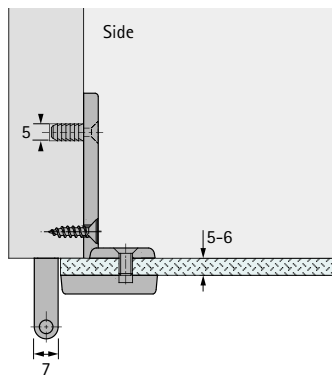

### Hole pattern glass door

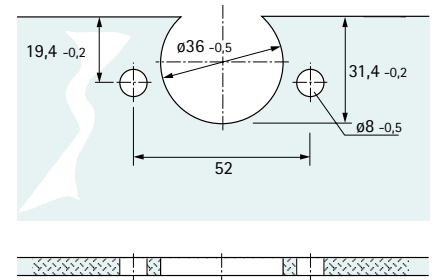

# ET 582 special-purpose hinge for refrigerator cabinets

## Specification

Hettich ET 582 special hinge for refrigerator cabinets  
 Opening angle 95°  
 Self-closing



### ET 582 special-purpose hinge for refrigerator cabinets

Self-closing  
 Opening angle 95°  
 Cup diameter 35 mm  
 Cup depth 12,8 mm

**Complete with mounting plate and clip-on plastic spacer.**  
**Plastic spacer increases plate distance by 3 mm.**

**Fixing countersunk screw  $\varnothing 3,5 \times 16$  mm, nickel-plated for Cup T 22, order no. 071 925, PU 200**

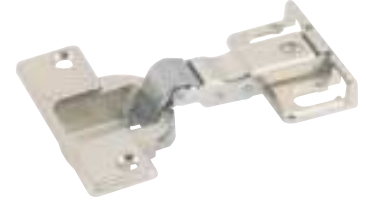

| Article  | Finish        | Order no. | PU     |
|--|---------------|-----------|--------|
| ET 582 special-purpose hinge for refrigerator cabinets, complete with mounting plate and plastic spacer. | nickel-plated | 072 134   | 10 pcs |

3

### Mounting example

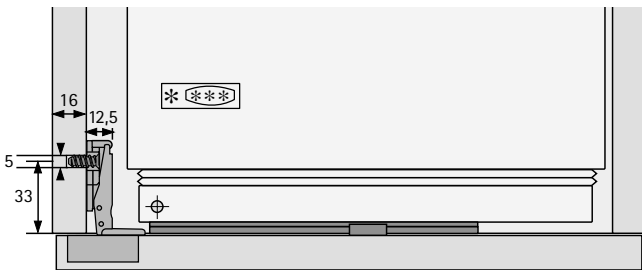

Mounting plate assembly, 33 mm from cabinet front edge  
 Overlay 14,5 mm for distance 3 mm and C distance 4,5 mm

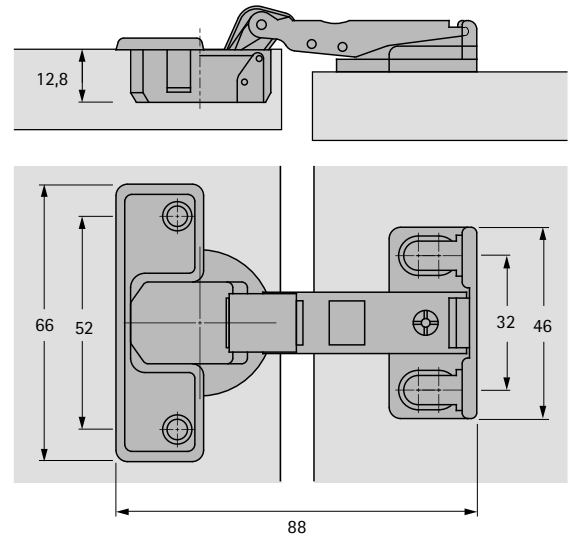

### Euro screws $\varnothing 6,3$ mm for the hinge arm

| Length mm | Finish        | Order no. | PU  |
|-----------|---------------|-----------|-----|
| 11        | nickel-plated | 040 006   | 200 |
| 13        | nickel-plated | 040 007   | 200 |
| 15        | nickel-plated | 040 008   | 200 |

### Hole pattern

Cup T 22 screw-on  
 C = 3 - 5 mm

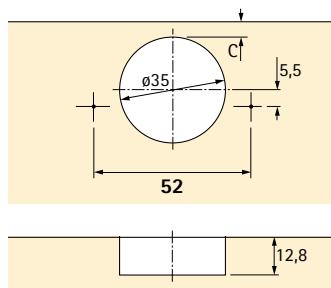

### Mounting plate + plastic spacer = distance 3 mm

| C distance | Overlay |
|------------|---------|
| 3,0 mm     | 13,0 mm |
| 3,5 mm     | 13,5 mm |
| 4,0 mm     | 14,0 mm |
| 4,5 mm     | 14,5 mm |
| 5,0 mm     | 15,0 mm |

### Mounting plate = distance 0 mm

| C distance | Overlay |
|------------|---------|
| 3,0 mm     | 16,0 mm |
| 3,5 mm     | 16,5 mm |
| 4,0 mm     | 17,0 mm |
| 4,5 mm     | 17,5 mm |
| 5,0 mm     | 18,0 mm |

# 625 hinge for flush-mounted doors and folding doors Opening angle 180°



## 625 hinge for flush-mounted doors and folding doors

Opening angle 180°

Nickel-plated steel, with fixed steel pin.  
Smooth action through wear-resistant  
washers with bushes.

The 625 is specially suited for use in  
folding door applications.



| Article                                     | Finish        | Order no. | PU     |
|---|---------------|-----------|--------|
| 625 folding door hinge                      | Steel         |           |        |
| Screw-on                                    | nickel-plated | 071 648   | 10 pcs |
| Press-in<br>with premounted dowels ø10 x 11 |               | 079 372   | 10 pcs |

## 625 folding door hinge

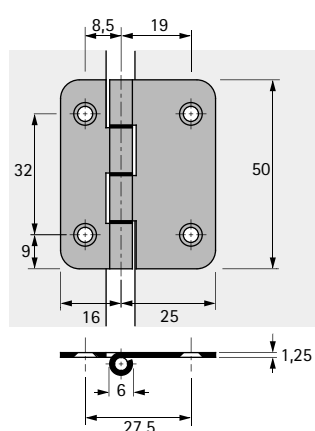

## Mounting with pivot offset

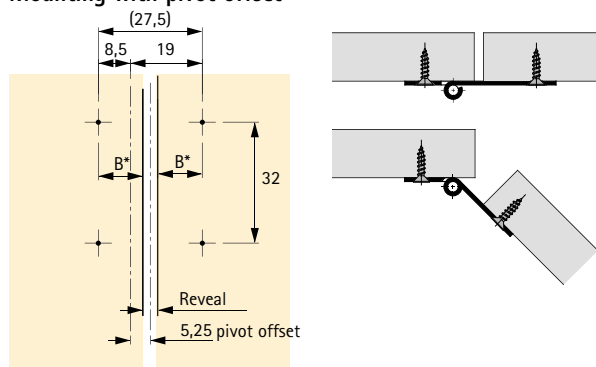

|                      |       |       |       |       |       |
|----------------------|-------|-------|-------|-------|-------|
| * B hole distance mm | 11,25 | 11,75 | 12,25 | 12,75 | 13,25 |
| Reveal mm            | 5     | 4     | 3     | 2     | 1     |

\* Make a trial mounting

## Fixing countersunk screws ø 3,5 mm, nickel-plated for folding door hinge 625

| Length mm | Order no. | PU  |
|-----------|-----------|-----|
| 13        | 048 296   | 200 |
| 15        | 071 925   | 200 |

For calculating pivot  
offset see below.

## Calculating the pivot offset for folding doors

- 1 Mount door section ① with 110° hinges on cabinet and adjust door reveal
- 2 Mount door section ② with runners and guides to runner and guide profiles and adjust door reveal (oval holes in runners and guides)
- 3 Fold door sections ① and ② in open position (see diagram)
- 4 Measure X at outer door edge
- 5 Measure L is the desired door clearance
- 6 Measure X (door offset) divided by two plus measure L (clearance) divided by two is the pivot offset

$$\frac{X+L}{2} = \text{pivot offset}$$

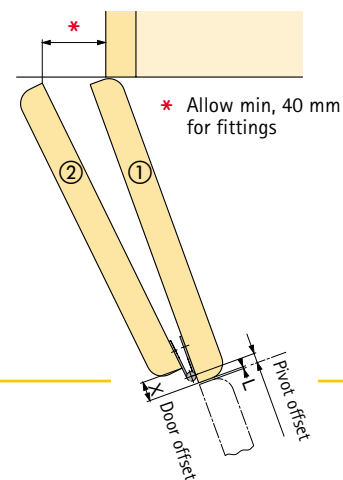

# Clip-on centre hinge

## Opening angle 180°



### Clip-on centre hinge for inset doors and folding doors

#### Opening angle 180°

Clip-on centre hinges allow door panels to be clipped on quickly and easily, zip-style, starting from the bottom.

Nickel-plated steel, fixing plate black plastic

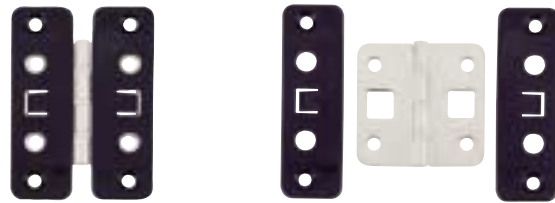

| Article                       | Order no. | PU     |
|-------------------------------|-----------|--------|
| Clip-on centre hinge screw-on | 079 373   | 10 pcs |

3

### Clip-on centre hinge

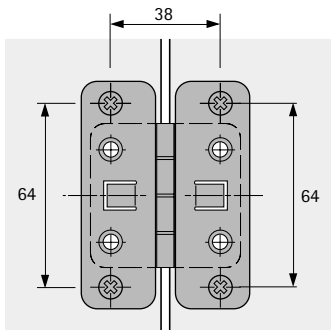

### Mounting with pivot offset

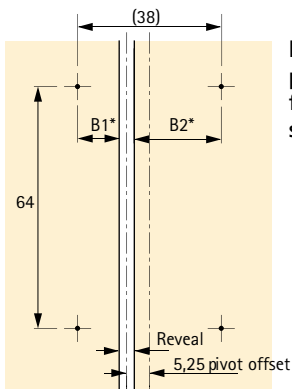

For calculating pivot offset for folding doors see page 3.192

### Centre mounting

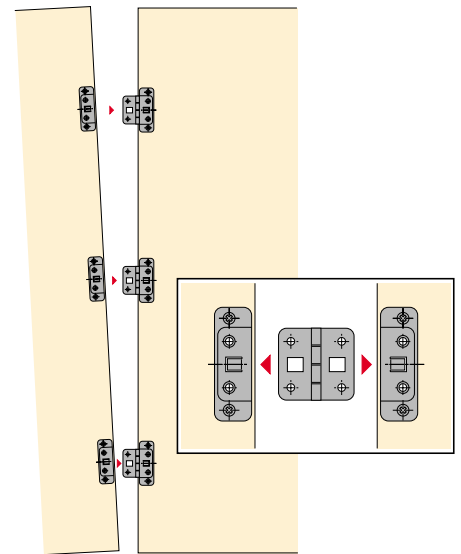
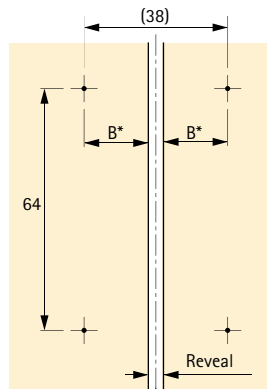

Fixing countersunk screws  
 ø 3,5 mm, nickel-plated  
 for folding door hinge 625

| Length mm | Order no. | PU  |
|-----------|-----------|-----|
| 13        | 048 296   | 200 |
| 15        | 071 925   | 200 |

|                        |      |    |      |    |      |
|------------------------|------|----|------|----|------|
| * B 1 hole distance mm | 10,5 | 11 | 11,5 | 12 | 12,5 |
| * B 2 hole distance mm | 22,5 | 23 | 23,5 | 24 | 24,5 |
| Reveal mm              | 5    | 4  | 3    | 2  | 1    |

\* Make a trial mounting

|                      |      |    |      |    |      |
|----------------------|------|----|------|----|------|
| * B hole distance mm | 16,5 | 17 | 17,5 | 18 | 18,5 |
| Reveal mm            | 5    | 4  | 3    | 2  | 1    |

\* Make a trial mounting

# Folding door hinge with offset pivot Opening angle 180°



## Double cup hinge with adjustable offset pivot

Opening angle 180°

Pivot offset adjustment in steps of 0 mm, 3 mm and 6 mm.

The reveal is adjustable from hairline to +4 mm.

The mounting is always flush.

Identical hole pattern for both doors, hinge parts are mounted separately.

Nickel-plated die-cast zinc



| Article   | Order no. | PU     |
|---|-----------|--------|
| Folding door hinge  |           |        |
| Screw-on  | 046 787   | 10 pcs |
| Press-in<br>with premounted $\varnothing 10 \times 11$ dowels | 052 095   | 10 pcs |

## Mounting example

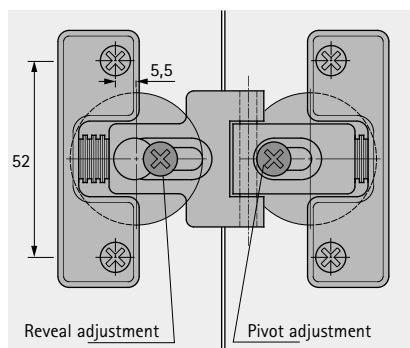
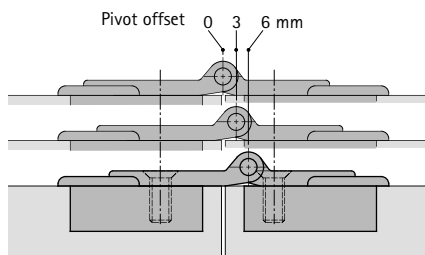
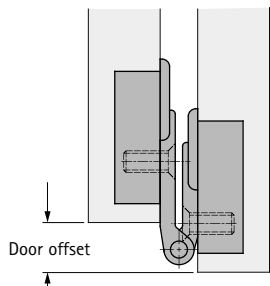
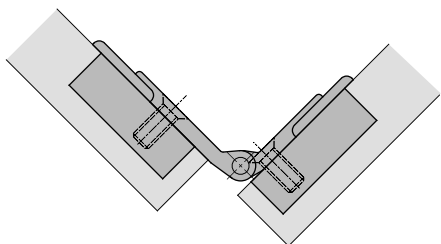

## Hole pattern press-in

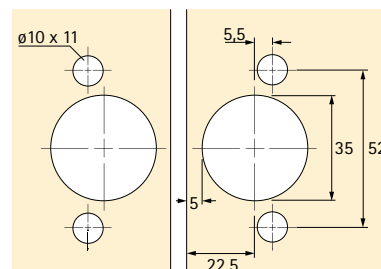

## Hole pattern screw on

Fixing countersunk screw  
 $\varnothing 3,5 \times 16$  mm, nickel-plated, for Cup T 42,  
order no. 071 925, PU 200

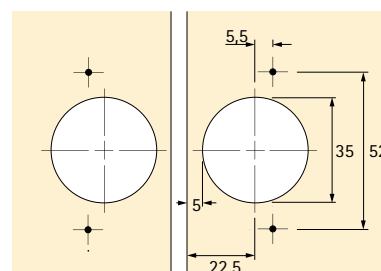

Example:  
For 3 mm reveal:

| Pivot offset | Door offset |
|--------------|-------------|
| 0 mm         | 0 mm        |
| 3 mm         | 6 mm        |
| 6 mm         | 12 mm       |

# Fascia hinge with spring system



## Fascia hinge with spring system

Suitable for mounting hinged fascias or for connecting two door sections on folding/sliding doors.

The integrated spring system keeps the door closed in a 90° position and also keeps the fascia aligned with the door.

The flat side arm takes up little space when the door is pushed into position between side panel and auxiliary panel.

The hinge is ideal for the Panorama 95 folding/sliding door fitting.

Nickel-plated die-cast zinc



| Article      | Finish                      | Order no. | PU     |
|--------------|-----------------------------|-----------|--------|
| Fascia hinge | nickel-plated die-cast zinc | 060 832   | 10 pcs |

3

## Mounting example

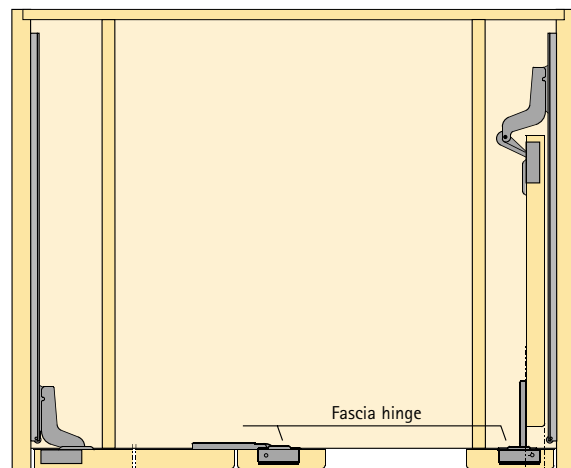
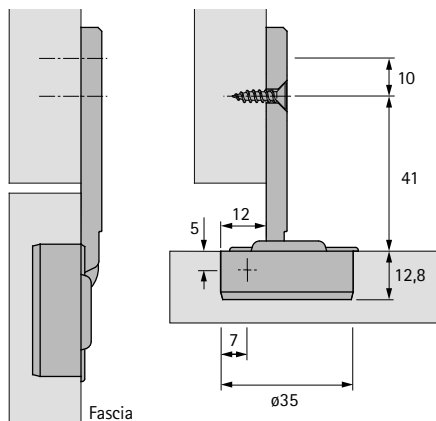

Panorama 95 with fascia hinge

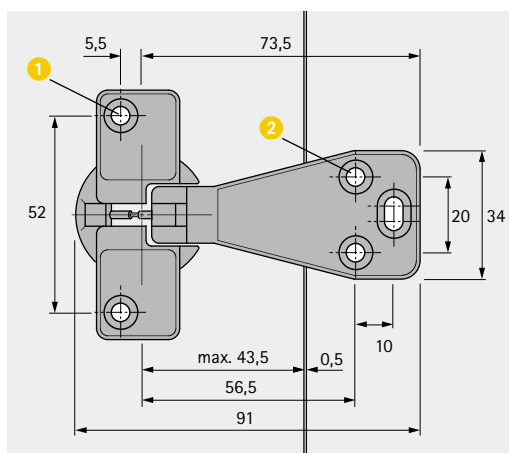

1 Fixing countersunk screw  $\varnothing$  3,5 x 16 mm, nickel-plated for the hinge cup, order no. 071 925, PU 200

2 Countersunk screws dia. 4 mm for hinge arm

| Length mm | Finish        | Order no. | PU  |
|-----------|---------------|-----------|-----|
| 16        | nickel-plated | 010 085   | 200 |
| 20        | nickel-plated | 046 638   | 200 |

# Optimat Plus Concealed hinge with Power Control for face frames



## Optimat Plus Concealed hinge with height and side adjustment and Power Control (spring force adjustment)

Opening angle 110°  
Suitable for all frame widths.  
Door overlay min. 35 mm,  
cup distance 4 mm.  
Cup diameter 35 mm  
Cup depth 12 mm



**Fixing countersunk screw**  $\varnothing 3,5 \times 13$  mm, nickel-plated  
for **Cup T 42**, order no. 048 296, PU 200

**Fixing countersunk screw**  $\varnothing 3,5 \times 16$  mm, nickel-plated  
for the **hinge arm**, order no. 071 925, PU 200

| Article            | Finish        | Order no. | PU     |
|--------------------|---------------|-----------|--------|
| Optimat Plus T 42  | nickel-plated | 079 384   | 10 pcs |
| Optimat Plus T 43  | nickel-plated | 072 885   | 10 pcs |
| Optimat Plus TB 43 | nickel-plated | 079 385   | 10 pcs |

### Mounting example

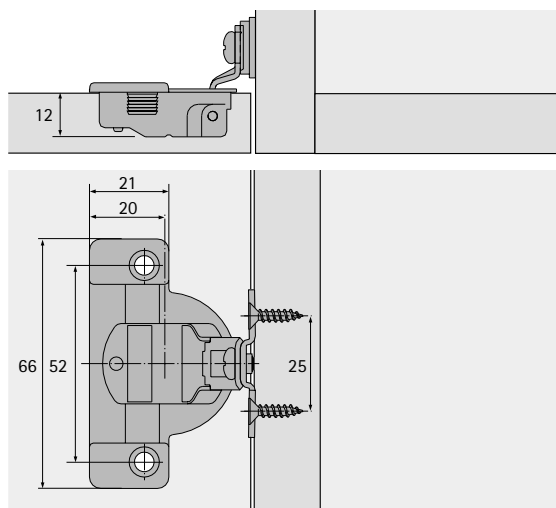
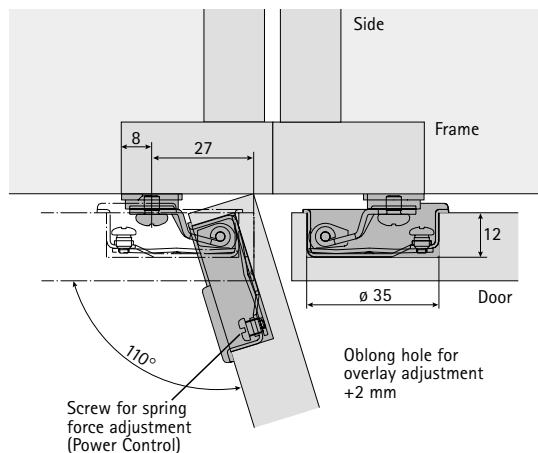

### T 42 hole dimensions

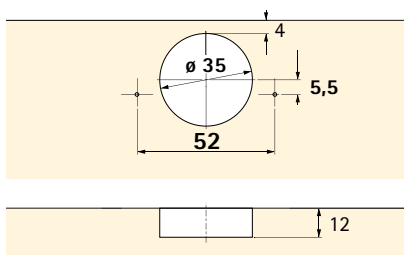

### T 43 hole dimensions

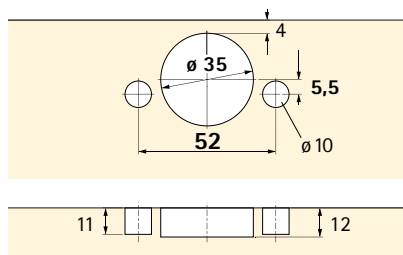

### TB 43 hole dimensions

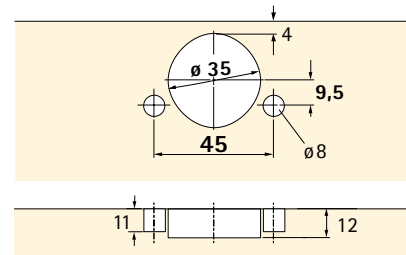

# Screw-on hinge with and without spring



## Screw-on hinge

For all applications where hinges requiring pre-drilled cup holes cannot be used.

Also suitable as flapstay hinge for lightweight flaps without flapstay.

Nickel-plated steel



Distance plate 2 mm stackable white plastic

| Article                       | Order no. | PU     |
|-------------------------------|-----------|--------|
| Screw-on hinge with spring    | 019 639   | 50 pcs |
| Screw-on hinge without spring | 019 640   | 50 pcs |
| Distance plate                | 019 641   | 50 pcs |

## Side panel mounting overlay door

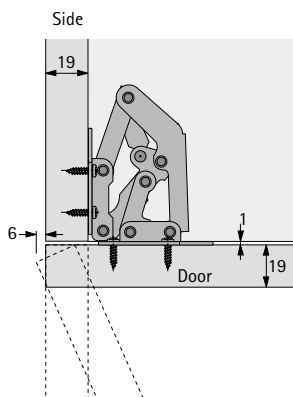

## Centre panel mounting half overlay doors

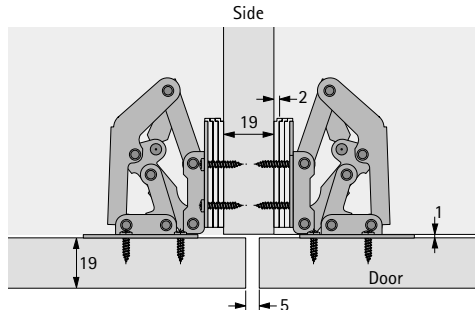

## Side panel mounting inset door

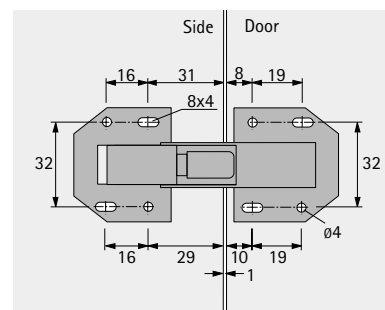
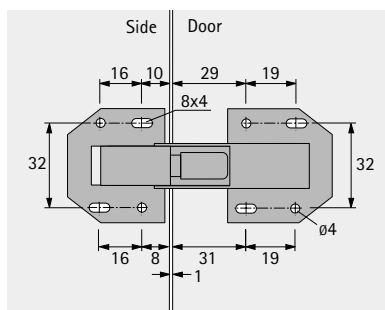
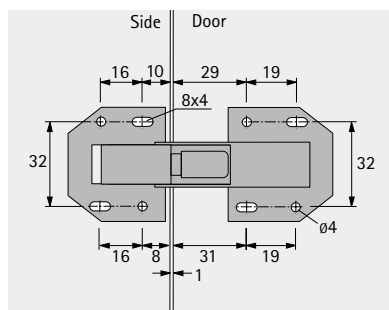
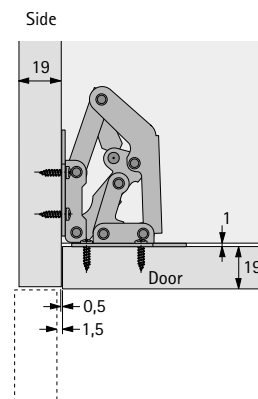

The diagrams show mounting examples for 19 mm thick side and door panels. For thinner side and centre panels, or if a larger reveal is needed, stack the distance plates to the required thickness.

Fixing countersunk screw  $\varnothing$  3,5 mm, nickel-plated for the screw-on hinge

| Length mm | Order no. | PU      |
|-----------|-----------|---------|
| 13        | 048 296   | 200 pcs |
| 16        | 071 925   | 200 pcs |

# Screw-on hinge with spring

## Opening angle 165-130°

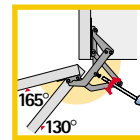

### Screw-on hinge Opening angle 165-130°

For all applications where hinges requiring pre-drilled cup holes cannot be used.

Opening angle 165° – the opening angle can be variably adjusted up to 130° with the adjustment screw.

Nickel-plated steel



| Article  | Order no. | PU     |
|--|-----------|--------|
| Screw-on hinge with spring<br>Opening angle 165-130° | 020 046   | 50 pcs |

### Side panel mounting overlay door

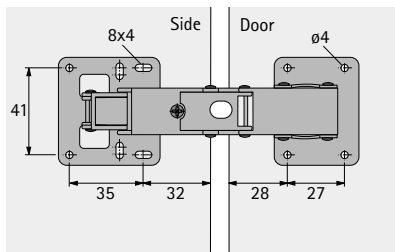
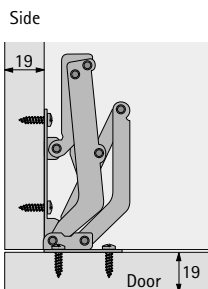

### Centre panel mounting half overlay doors

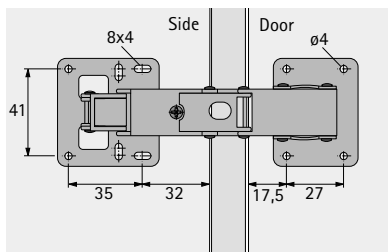
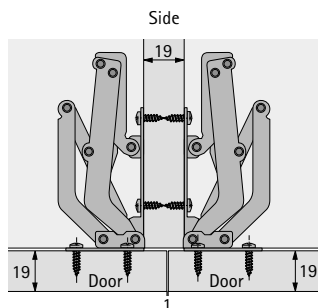

### Side panel mounting inset door

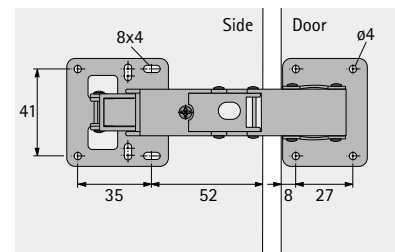
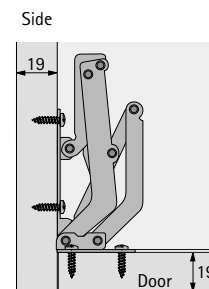

Fixing countersunk screw  $\varnothing$  3,5 mm, nickel-plated for the screw-on hinge

| Length mm | Order no. | PU      |
|-----------|-----------|---------|
| 13        | 048 296   | 200 pcs |
| 16        | 071 925   | 200 pcs |

# Mini screw-on hinge with spring

## Opening angle 90°



### Mini screw-on hinge with spring, Opening angle 90°

For all applications where hinges requiring pre-drilled cup holes cannot be used.

The hinge is normally used for small doors.

Nickel-plated steel



| Article  | Order no. | PU     |
|--|-----------|--------|
| Mini screw-on hinge with spring<br>Opening angle 90° | 020 126   | 50 pcs |

### Side panel mounting overlay door

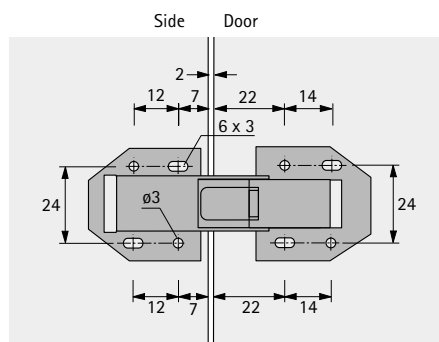
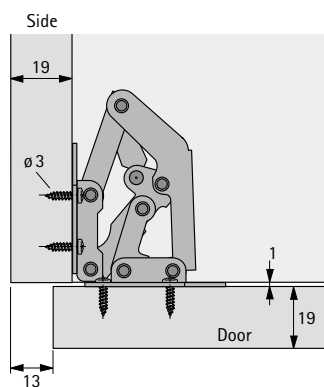

# Excellent Concealed cylinder hinge

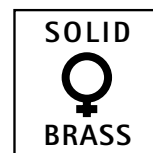

**Excellent  
Concealed cylinder hinge  
for doors and flaps  
Brass**

Quick and easy to mount  
Opening angle 180°  
Usable left or right  
Brushed matt brass



| Article                  | Finish                | Order no. | PU     |
|--------------------------|-----------------------|-----------|--------|
| Concealed-cylinder hinge | brass<br>brushed matt |           |        |
| ø 10 mm                  |                       | 031 168   | 48 pcs |
| ø 12 mm                  |                       | 031 169   | 48 pcs |
| ø 14 mm                  |                       | 031 170   | 24 pcs |
| ø 16 mm                  |                       | 031 171   | 24 pcs |
| ø 18 mm                  |                       | 031 172   | 24 pcs |
| ø 24 mm                  |                       | 031 173   | 12 pcs |

3

## Mounting examples

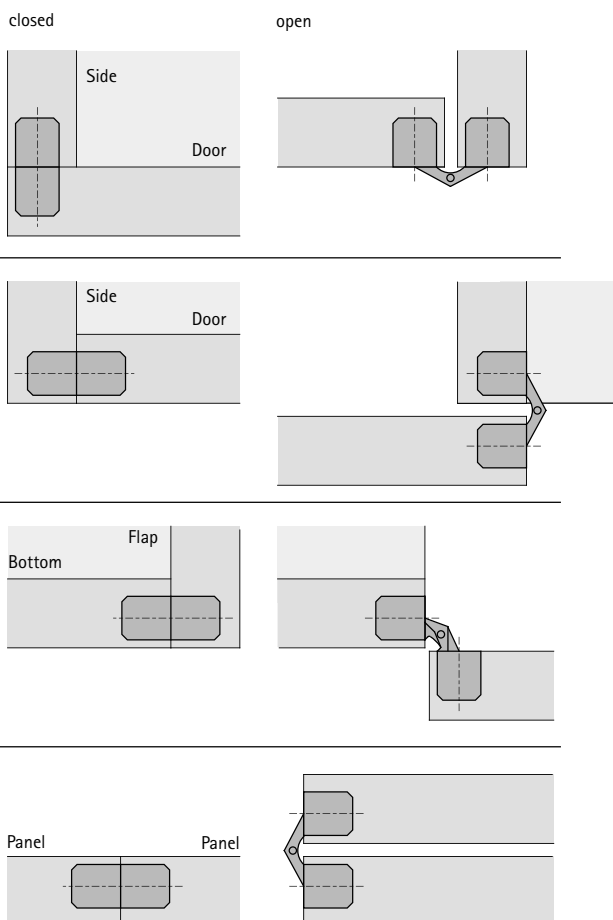

## ø 10 mm

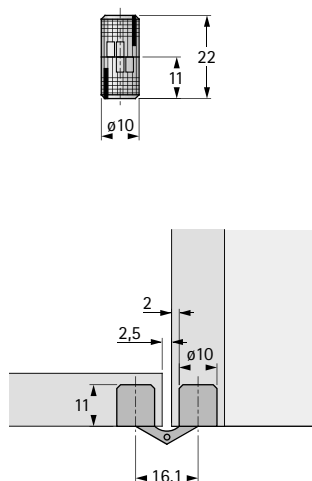

Fasten with countersunk wood screw ø 2 mm DIN 97

## ø 12 mm

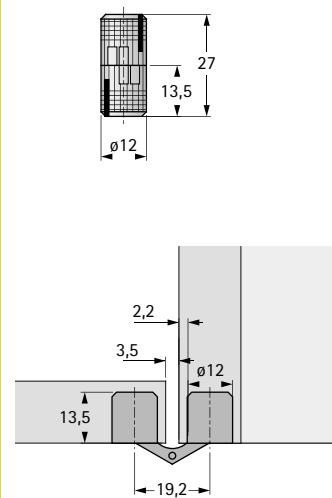

Fasten with countersunk wood screw ø 2,5 mm DIN 97

The Excellent hinge has attractive features for modern furniture designs.

For quick and easy assembly follow the steps as shown in the diagrams. For bigger loads the hinge cylinders can be glued in for added strength.



Drill holes



Insert hinge cylinders either with or without glue



Fasten with expanding screws and wood screws

ø 14 mm

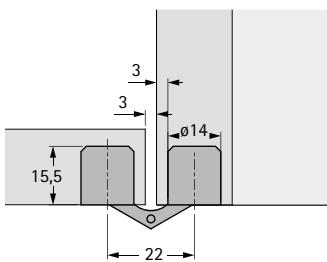
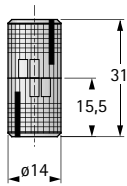

Fasten with countersunk wood screw ø 2,5 mm DIN 97

ø 16 mm

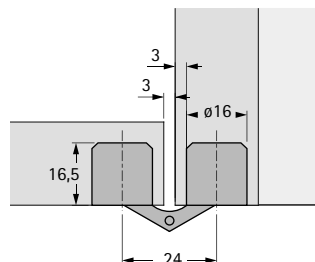
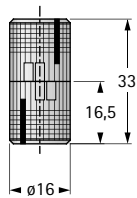

Fasten with countersunk wood screw ø 3 mm DIN 97

ø 18 mm

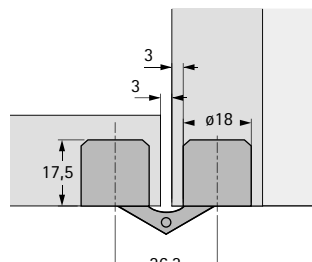
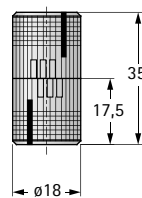

Fasten with countersunk wood screw ø 3 mm DIN 97

ø 24 mm

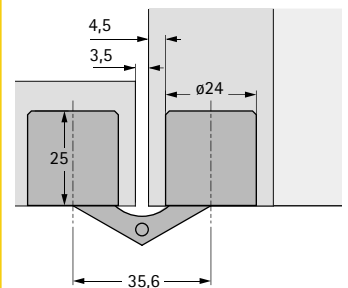
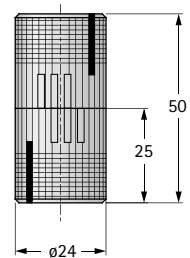

Fasten with countersunk wood screw ø 3,5 mm DIN 97

# Hinge Stabilo 72

3



## Stabilo 72 hinge for lightweight furniture doors and flaps All-metal version

Rounded flaps for machine countersinking,  
router cutter  $\varnothing$  14 mm.

Opening angle 180°  
Usable left or right



| Article    | Finish        | Order no. | PU     |
|------------|---------------|-----------|--------|
| Stabilo 72 | nickel-plated | 031 177   | 10 pcs |
|            | bronze        | 042 557   | 10 pcs |
|            | brass-plated  | 042 558   | 10 pcs |

### Mounting examples

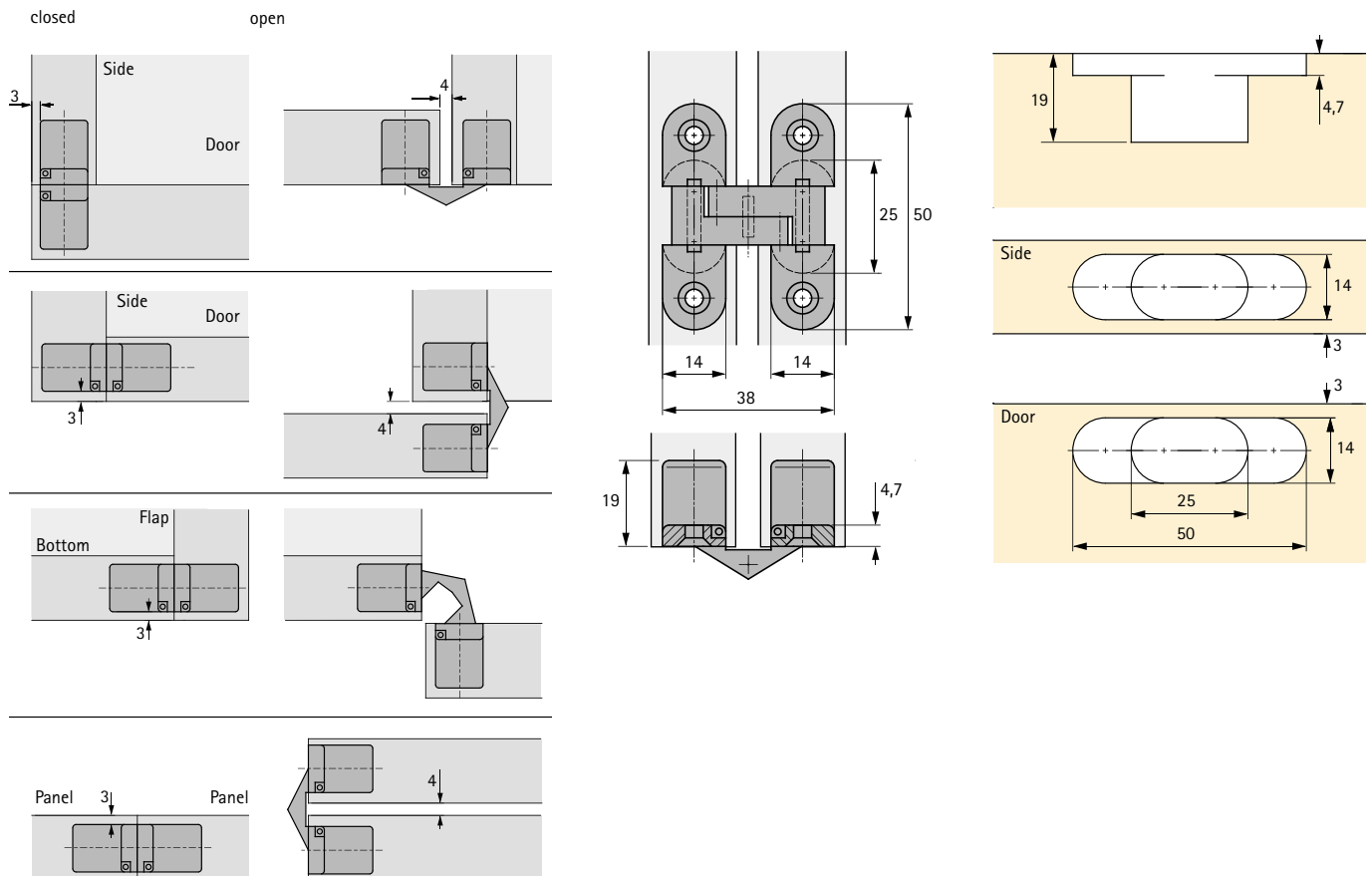

Fasten with countersunk wood screw  $\varnothing$  3 mm DIN 97

# Hinge Stabilo 75



## Stabilo 75 hinge for folding doors, lightweight furniture doors and flaps

For machine countersinking,  
router cutter  $\varnothing$  11 mm.

Durable plastic housing and  
nickel-plated brass links.

Opening angle 180°  
Usable left or right



| Article    | Hinge arm              | Housing          | Order no. | PU     |
|------------|------------------------|------------------|-----------|--------|
| Stabilo 75 | brass<br>nickel-plated | plastic<br>white | 042 339   | 10 pcs |
| Stabilo 75 | brass<br>nickel-plated | plastic<br>brown | 042 340   | 10 pcs |

## Mounting examples

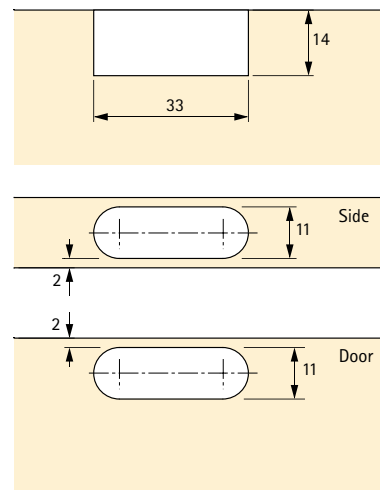
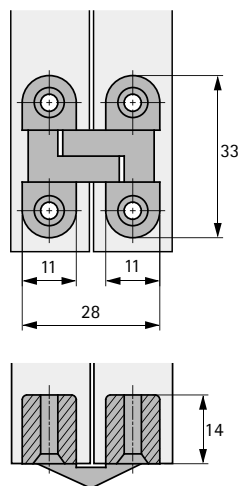
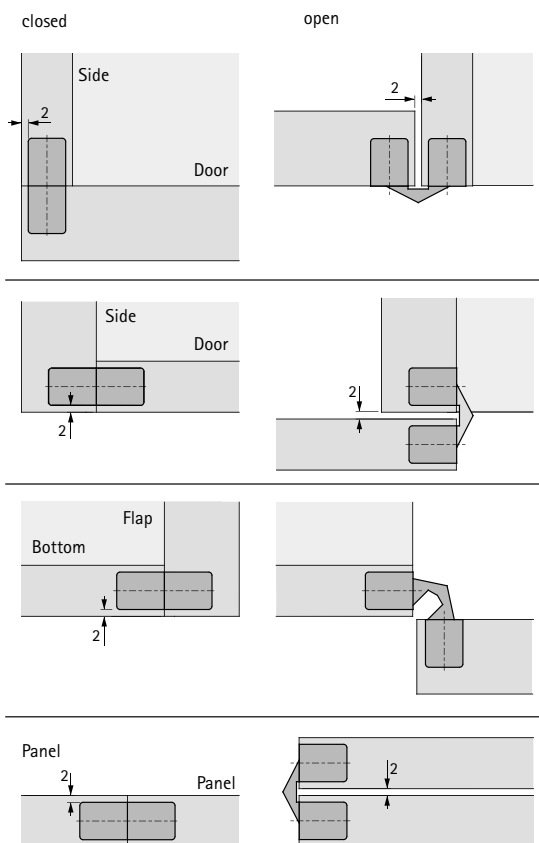

Fasten with countersunk wood screw  $\varnothing$  3 mm DIN 97

# Hinge Niro 66



**Niro 66 hinge for room doors, concertina and folding doors, access doors for dividing walls, windows, wall cabinets, heavy cupboard doors, folding tables, etc. Stainless steel**

Polished and brushed, with plastic housing and rounded flaps for machine countersinking, router cutter  $\varnothing$  25 mm.

Opening angle 180°  
**Usable left or right**

Stainless steel ground and brushed



| Article       | Order no. | PU    |
|---------------|-----------|-------|
| Niro 66 hinge | 031 184   | 2 pcs |

## Mounting examples

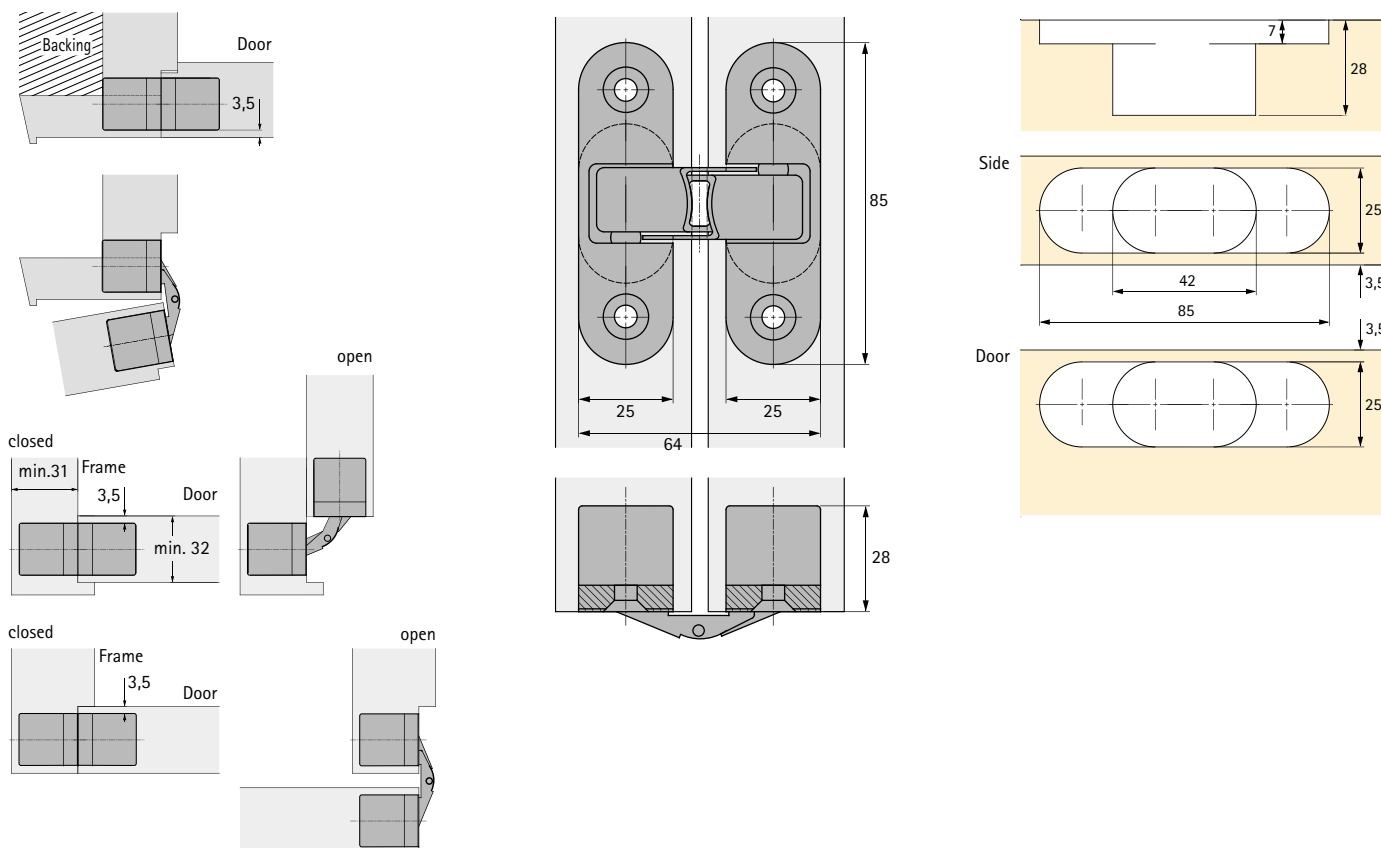

Fasten with countersunk wood screws  $\varnothing$  5,5 mm DIN 97

# Sepa Hinge

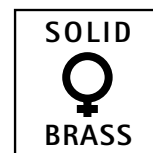

## Sepa hinge for doors, windows and flaps Matt brass

With rounded flaps for machine countersinking, router cutter  $\varnothing$  9 and 18 mm.

Opening angle 180°  
Usable left or right  
Matt brushed brass



| Article  | Order no. | PU     |
|--|-----------|--------|
| Sepa hinge   |           |        |
| Flap length 39 mm, router cutter $\varnothing$ 9 mm  | 046848    | 10 pcs |
| Flap length 41 mm, router cutter $\varnothing$ 18 mm | 031174    | 10 pcs |
| Flap length 52 mm, router cutter $\varnothing$ 18 mm | 031175    | 10 pcs |
| flap length 88 mm, router cutter $\varnothing$ 18 mm | 031176    | 10 pcs |

3

Flap length 39 mm  
Router cutter  $\varnothing$  9 mm

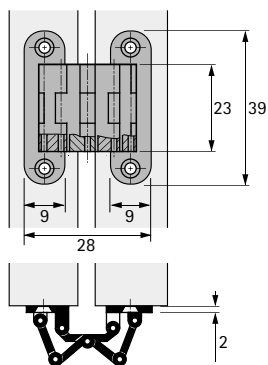

Flap length 41 mm  
Router cutter  $\varnothing$  18 mm

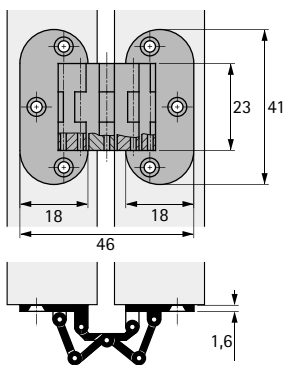

Flap length 52 mm  
Router cutter  $\varnothing$  18 mm

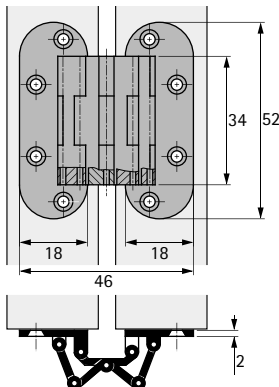

Flap length 88 mm  
Router cutter  $\varnothing$  18 mm

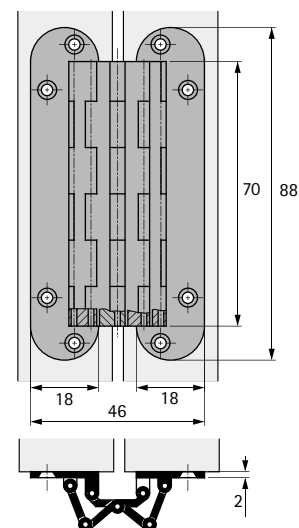

Mounting example  
for hinge length 39 mm  
router cutter  $\varnothing$  9 mm

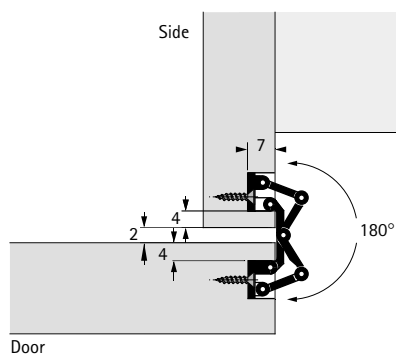
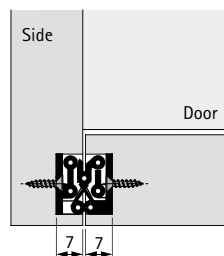

Mounting examples for  
hinge lengths 41/52/88 mm  
router cutter  $\varnothing$  18 mm

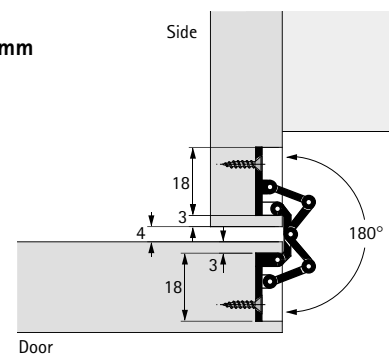
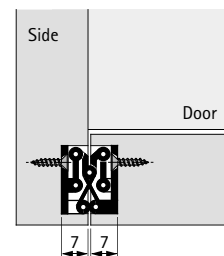

Fasten with countersunk wood screws  $\varnothing$  2,7 DIN 97

# ET 150 glass door hinge

## Door handle

## D7 magnetic catch

3



### ET 150 glass door hinge for inset doors

Door size max. 1000 x 500 mm  
 Opening angle 105°, glass thickness max. 5,2 mm  
 Requires 3 mm gap top and bottom and 2,8 mm gap at the side.

The hinge is clamped to the glass door with a screw, **no hole** has to be drilled in the glass.  
 Die-cast zinc

### Handle

The design matches the ET 150 glass door hinge.  
 The handle is clamped to the glass door with a screw.  
 Die-cast zinc

A **D7 magnetic catch** can be used to keep the door closed.

| Article                 | Material / Finish                | Order no. | PU      |
|-------------------------|----------------------------------|-----------|---------|
| ET 150 glass door hinge | matt nickel-plated die-cast zinc | 020 870   | 20 sets |
| Handle left             | matt nickel-plated die-cast zinc | 020 871   | 20 pcs  |
| Handle right            | matt nickel-plated die-cast zinc | 020 872   | 20 pcs  |
| D7 magnetic catch       | black plastic                    | 020 873   | 20 pcs  |

The glass door hinge is supplied only as a set consisting of the top and bottom hinges.

### Mounting examples

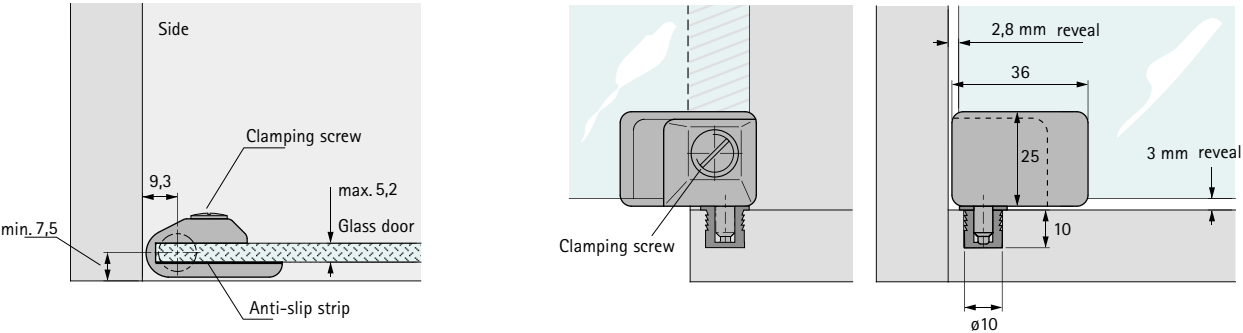

# ET 5160 glass door hinge with self-closing feature

## Overlay doors



### ET 5160 glass door hinge for overlay doors

Door size max. 1000 x 600 mm  
 Opening angle 170°, glass thickness max. 6,3 mm  
 Door overlay top and bottom 3,3 mm, on sides 11,5 mm.  
 The hinge is clamped to the glass door with a screw, no hole has to be drilled in the glass.

Die-cast zinc

### Glass door handle

The design matches the ET 5160 glass door hinge. The handle is clamped to the glass door with a screw.

Die-cast zinc

| Article                  | Material / Finish   | Order no.          | PU                 |
|--------------------------|---|--------------------|--------------------|
| ET 5160 Glass door hinge | matt nickel-plated die-cast zinc<br>high-gloss gold die-cast zinc | 030 866<br>040 719 | 20 sets<br>20 sets |
| Glass door handle        | matt nickel-plated die-cast zinc<br>high-gloss gold die-cast zinc | 025 314<br>025 315 | 20 pcs<br>20 pcs   |

The glass door hinge is supplied only as a set consisting of the top and bottom hinges.

### Mounting examples

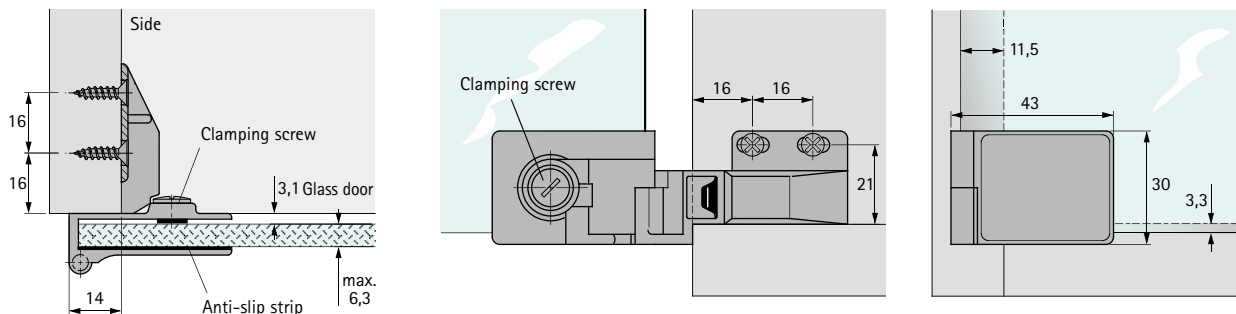

Fasten with wood screws  $\varnothing$  3,5 mm

# ET 5150 glass door hinge with self-closing feature

## Inset doors

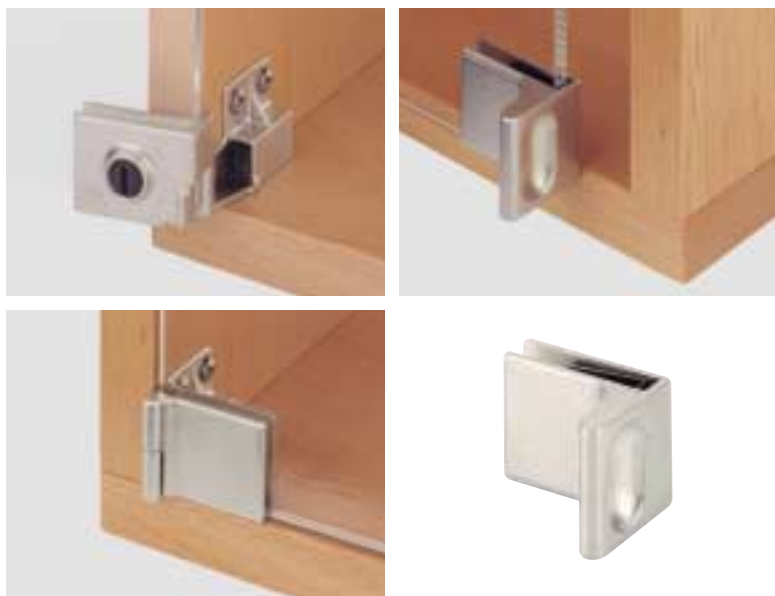

### ET 5150 glass door hinge for inset doors

Door size max. 1000 x 600 mm  
 Opening angle 170°, glass thickness max. 6,3 mm  
 Requires 2,2 mm gap top and bottom and 2 mm gap at the side.

The hinge is clamped to the glass door with a screw, no hole has to be drilled in the glass.

**\* glass door hinge ET 5150 Z needs to be used for high doors, see page 3.209!**

Die-cast zinc

### Glass door handle

The design matches the ET 5150 glass door hinge. The handle is clamped to the glass door with a screw.  
 Die-cast zinc

3

| Article                  | Material / Finish   | Order no.          | PU                 |
|--------------------------|---|--------------------|--------------------|
| ET 5150 glass door hinge | matt nickel-plated die-cast zinc<br>high-gloss gold die-cast zinc | 024 908<br>024 909 | 20 sets<br>20 sets |
| Glass door handle        | matt nickel-plated die-cast zinc<br>high-gloss gold die-cast zinc | 025 314<br>025 315 | 20 pcs<br>20 pcs   |

The glass door hinge is supplied only as a set consisting of the top and bottom hinges.

### Mounting examples

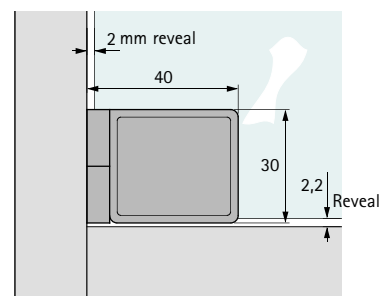
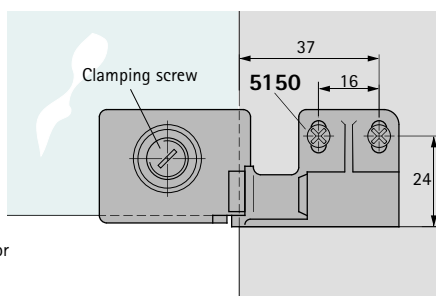
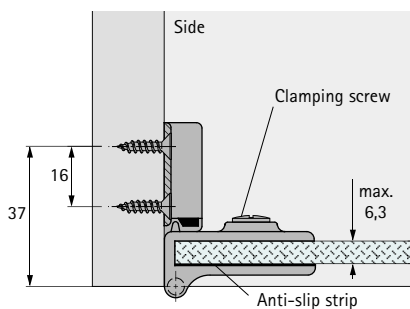

**\* ET 5150 and ET 5150 Z glass door hinges combined on high doors**

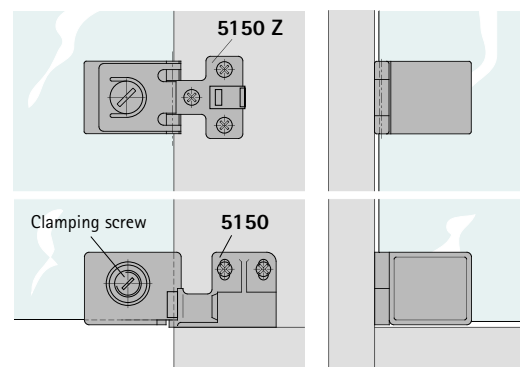

Fasten with wood screws  $\varnothing$  3,5 mm

# ET 5150 Z glass door hinge with self-closing feature Inset doors



## ET5150Z glass door hinge for inset doors

Opening angle 180°

Glass thickness max. 6,3 mm, hole  $\varnothing$  11 mm

Requires a 2 mm gap on the side.

Die-cast zinc

\* The glass door hinge has the same design as the 5150 hinge and can be combined with it on higher doors, see page 3.208!



3

| Article                                   | Finish  | Order no.          | PU               |
|---|---|--------------------|------------------|
| ET 5150 Z glass door hinge with cover cap | matt nickel-plated die-cast zinc<br>high-gloss gold die-cast zinc | 069 934<br>069 935 | 10 pcs<br>10 pcs |

## Mounting examples

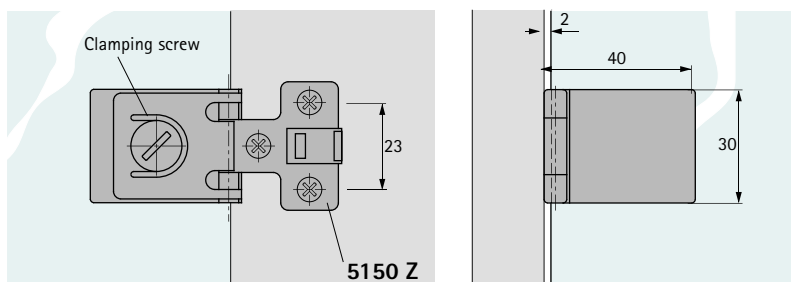
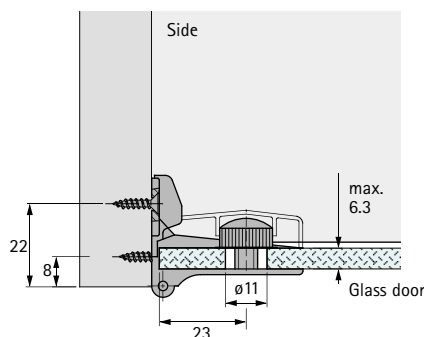

\* ET 5150 Z and ET 5150 glass door hinges combined on high doors

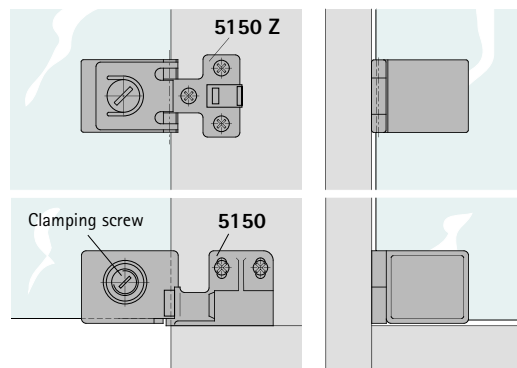

Fasten with wood screws  $\varnothing$  3,5 mm

# Phono glass door hinge

## Glass door handle



### Glass door hinge for inset glass doors

Glass thickness 5 - 6 mm. Requires a 2,5 mm gap top and bottom and 3 mm gap on the side.

The hinge is clamped to the glass door with a screw, **no hole has to be drilled in the glass.** With spring mechanism.

Fastened on the side panel with **countersunk  $\varnothing$  3 mm wood screws, head  $\varnothing$  5 mm.** The anti-slip strip ensures that the glass door is held securely.

Die-cast zinc



### Glass door handle

The design matches the phono glass door hinge. The handle is clamped to the glass door with a screw, in any position.

The recessed area in the handle means that despite its slight format the door can be handled safely and easily.

Die-cast zinc

3

| Article                    | Material / Finish           | Order no. | PU      |
|----------------------------|-----------------------------|-----------|---------|
| GT 3165 glass door hinge   | nickel-plated die-cast zinc | 042 344   | 10 sets |
| GT 3145 glass door hinge   | black die-cast zinc         | 072 888   | 10 sets |
| GTG 3220 glass door handle | nickel-plated die-cast zinc | 042 350   | 10 pcs  |
| GTG 3210 glass door handle | black die-cast zinc         | 072 889   | 10 pcs  |

The glass door hinge is supplied only as a set consisting of the top and bottom hinges.

### Mounting examples

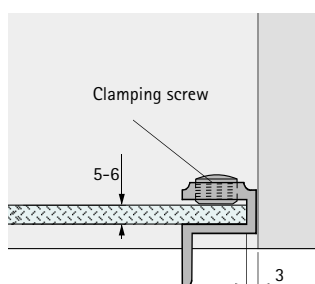
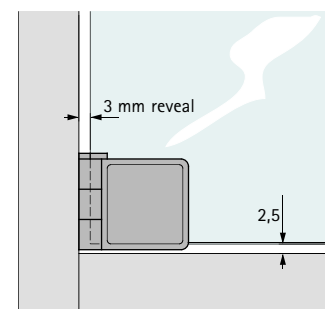
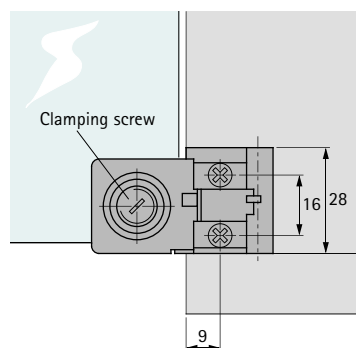
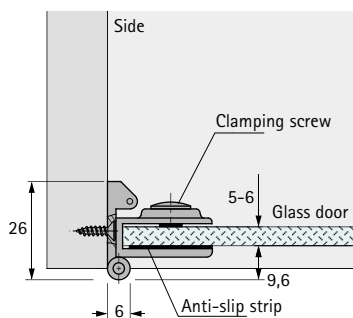

# Glass door hinge GT 3000

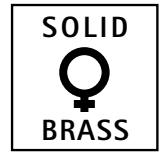

## GT 3000 glass door hinge for inset glass doors Brass version

Turned and milled, glass thickness 4,5 - 6,5 mm.  
Glass hole  $\varnothing$  19 mm. Fasten with keyed nut, pin wrench DIN 1810.  
Automatic compensation for glass thickness tolerances.  
For 32 mm hole line spacing. Tarnish resistant.  
Holding feature at approx. 105° opening angle.  
Door and cabinet hinge parts are mounted separately.  
Detachable door with safety feature against accidental unHINGING.  
Door and frame parts secured by self-locking screw.

Height adjustment approx. 2 mm  
Side adjustment approx. 2,5 mm  
Front panel  $\varnothing$  25 mm



3

| Article                  | Finish                                     | Order no.          | PU               |
|--------------------------|--|--------------------|------------------|
| GT 3000 glass door hinge | polished brass<br>high-gloss chrome-plated | 031 107<br>031 108 | 20 pcs<br>20 pcs |

### Mounting examples

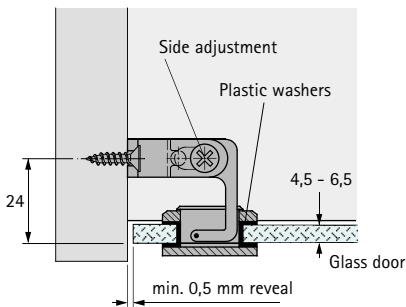

Fasten with  $\varnothing$  3,5 mm wood screws

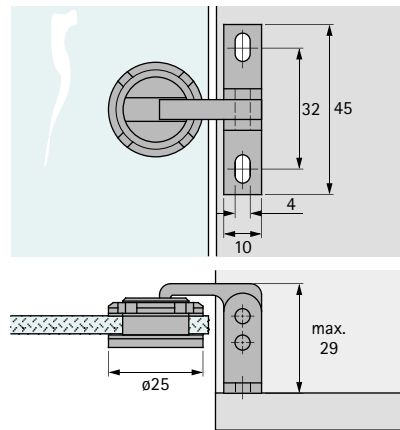

### Glass hole

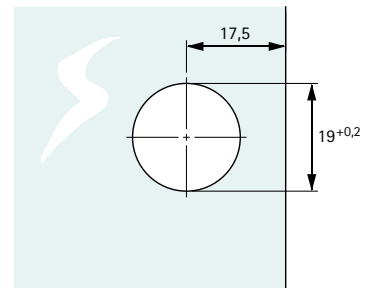

# Glass door hinge GT 6000

3



## GT 6000 glass door hinge for inset or overlay glass doors

Glass thickness 4,5 - 7 mm.

With unique catch operation, rugged all-metal version, elegant form, simple assembly.

Side- and height-adjustable for 32 mm hole line spacing, 30 - 37 mm variable hole line adjustment.

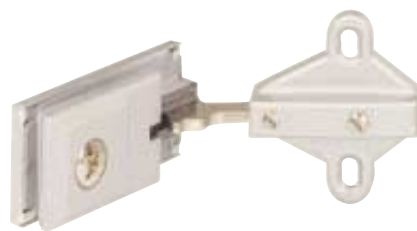

| Article                           | Finish<br>Decorative cap | Finish<br>Hinge | Order no. | PU     |
|-----------------------------------|--------------------------|-----------------|-----------|--------|
| Glass door hinge<br>Overlay 6 mm  | polished silver-coloured | silver-coloured | 031 115   | 20 pcs |
| Glass door hinge<br>Overlay 13 mm | polished silver-coloured | silver-coloured | 031 118   | 20 pcs |
| Glass door hinge<br>Inset door    | polished silver-coloured | silver-coloured | 031 121   | 20 pcs |

## Mounting examples

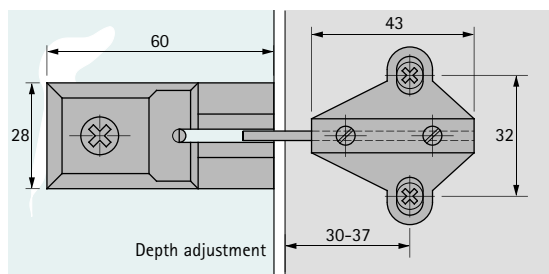

## Glass hole

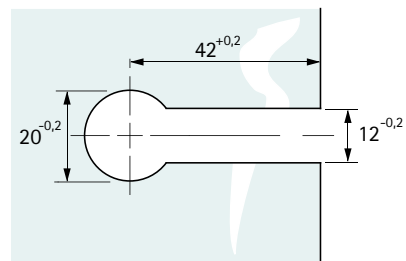

## Overlay 6 mm

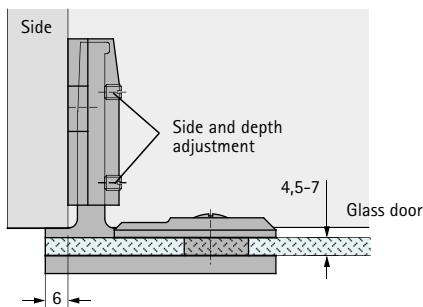

## Overlay 13 mm

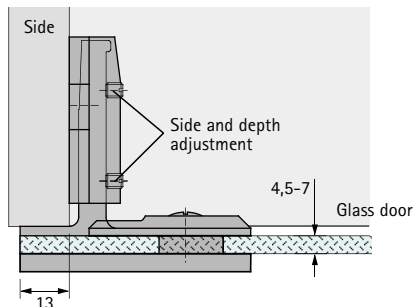

## Inset door

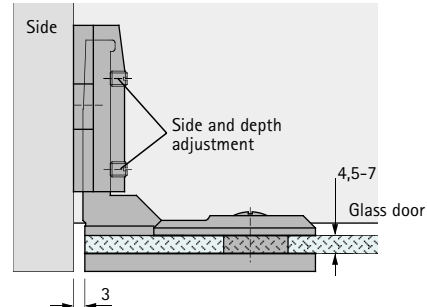

# Programme overview



Butt hinges, surface hinges, piano hinges, swing door fittings, flap hinges, table hinges, special hinges  
Pages 3.214 – 3.268



**Flap fittings**  
Pages 3.269 – 3.287



**Lift-up flap fittings**  
Pages 3.288 – 3.305



**Swivel fitting Horizon Plus**  
Pages 3.306 – 3.313

# Technical information

## Butt hinges

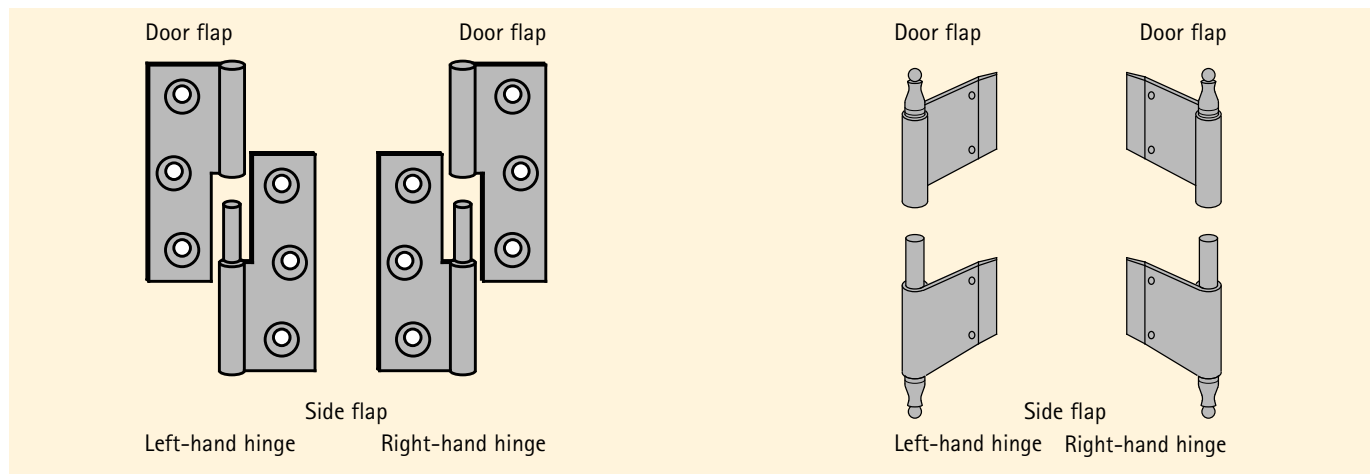

### Left-handed and right-handed flaps of butt hinges

To differentiate between the left and right flap of screw-on butt hinges, these **must be folded open and viewed from the side with the countersunk holes for the screws.**

For a **left-handed hinge**, the door flap is on the **left**.

For a **right-handed hinge**, the door flap is on the **right**.

### Left-handed and right-handed flaps of mortise hinges

To differentiate between the left and right flap of mortise hinges, these must be folded open and viewed from the knuckle side.

For a **left-handed door flap**, the hinge flap is attached on the **left side** of the knuckle.

For a **right-handed door flap**, the hinge flap is attached on the **right side** of the knuckle.

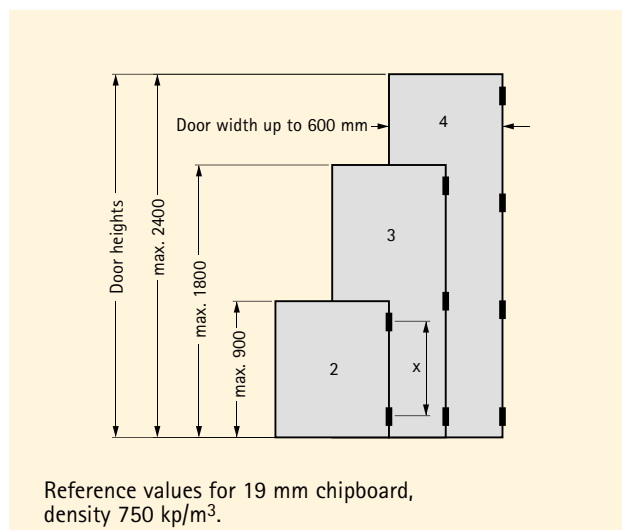

### Number of hinges per door

Door weight, door width, quality of the material and hinge mounting are important factors to be considered when determining the number of hinges required per door.

Factors encountered in practise vary considerably. That is why the hinge numbers given in the diagram serve only as guidelines.

If in doubt, it is best to make a trial mounting.

For stability reasons, the hinge distance X must be chosen as large as possible.

### Mounting options

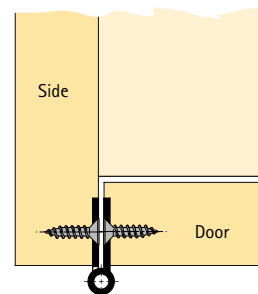

Flush door, straight

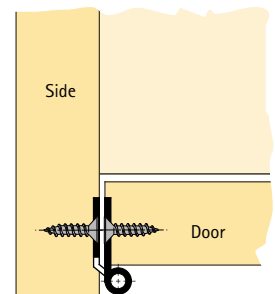

Recessed door, cranking B

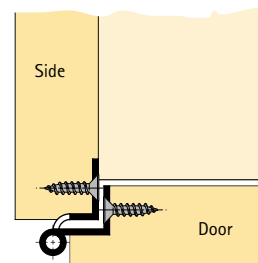

Rebated door, cranking D

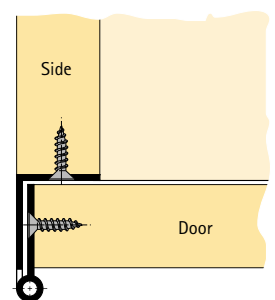

Corner hinge  
Offset door, cranking L

# Butt hinge 300 straight



## Specification

Hettich butt hinge 300, straight, from drawn brass, drilled and milled. Knuckle  $\varnothing$  8 mm, flap thickness 1,7 mm Countersunk holes

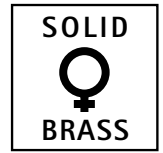

### Butt hinge for inset doors Solid brass

Knuckle  $\varnothing$  8 mm, flap thickness 1,7 mm  
Drawn brass, drilled and milled, with steel pin and milled countersunk holes, without wash

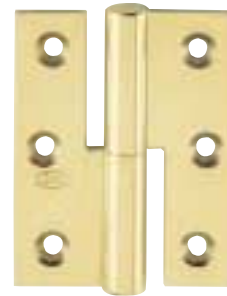

3

| Article                       | Finish                   | Hinge length 40 mm |        | Hinge length 50 mm |        | Hinge length 60 mm |        |
|-------------------------------|--------------------------|--------------------|--------|--------------------|--------|--------------------|--------|
|                               |                          | Order no.          | PU     | Order no.          | PU     | Order no.          | PU     |
| Butt hinge 300 left straight  | polished brass           | 042 278            | 10 pcs | 031 000            | 10 pcs | 031 963            | 10 pcs |
|                               | matt brushed brass       | -                  | -      | 031 001            | 10 pcs | 031 962            | 10 pcs |
|                               | high-gloss nickel-plated | 031 942            | 10 pcs | 031 002            | 10 pcs | 042 281            | 10 pcs |
|                               | nickel-plated matt       | 031 941            | 10 pcs | 031 003            | 10 pcs | 042 282            | 10 pcs |
| Butt hinge 300 right straight | polished brass           | 031 946            | 10 pcs | 031 004            | 10 pcs | 031 968            | 10 pcs |
|                               | matt brushed brass       | -                  | -      | 031 005            | 10 pcs | 031 967            | 10 pcs |
|                               | high-gloss nickel-plated | 042 280            | 10 pcs | 031 006            | 10 pcs | 031 966            | 10 pcs |
|                               | nickel-plated matt       | 031 944            | 10 pcs | 031 007            | 10 pcs | 031 965            | 10 pcs |

### Mounting example

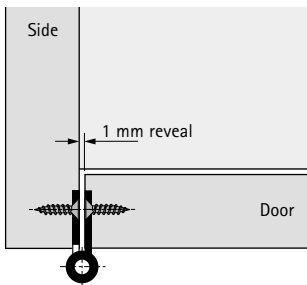

Fasten with countersunk wood screws  $\varnothing$  3 DIN 97

### Hinge length 40 mm

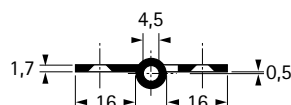
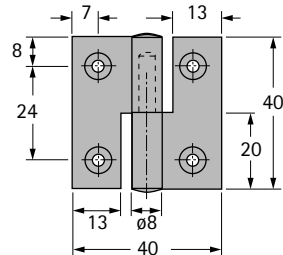

### Hinge length 50 mm

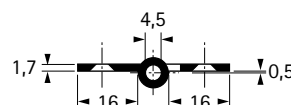
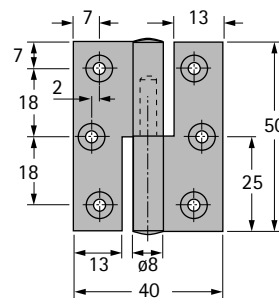

### Hinge length 60 mm

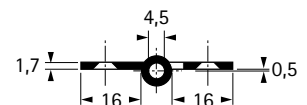
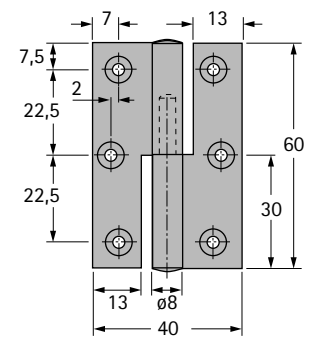

# Butt hinge 300 cranking B



## Specification

Hettich butt hinge 300, cranking B, from drawn brass, drilled and milled. Knuckle  $\varnothing$  8 mm, flap thickness 1,7 mm Countersunk holes

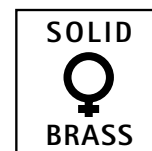

### Butt hinge for recessed doors

#### Solid brass

Knuckle  $\varnothing$  8 mm, flap thickness 1,7 mm

Drawn brass, drilled and milled, with steel pin and milled countersunk holes, without washer.

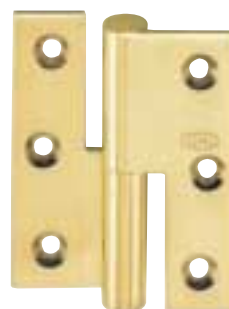

3

| Article                         | Finish                   | Hinge length 40 mm |        | Hinge length 50 mm |        | Hinge length 60 mm |        |
|---------------------------------|--------------------------|--------------------|--------|--------------------|--------|--------------------|--------|
|                                 |                          | Order no.          | PU     | Order no.          | PU     | Order no.          | PU     |
| Butt hinge 300 left cranking B  | polished brass           | 031 935            | 10 pcs | 031 008            | 10 pcs | 031 955            | 10 pcs |
|                                 | matt brushed brass       | -                  | -      | 031 009            | 10 pcs | 031 954            | 10 pcs |
|                                 | high-gloss nickel-plated | -                  | -      | 031 010            | 10 pcs | -                  | -      |
|                                 | nickel-plated matt       | 031 934            | 10 pcs | 031 011            | 10 pcs | 042 286            | 10 pcs |
| Butt hinge 300 right cranking B | polished brass           | 031 939            | 10 pcs | 031 012            | 10 pcs | 031 957            | 10 pcs |
|                                 | matt brushed brass       | -                  | -      | 031 013            | 10 pcs | 031 956            | 10 pcs |
|                                 | high-gloss nickel-plated | -                  | -      | 031 014            | 10 pcs | -                  | -      |
|                                 | nickel-plated matt       | 031 937            | 10 pcs | 031 015            | 10 pcs | 042 288            | 10 pcs |

### Mounting example

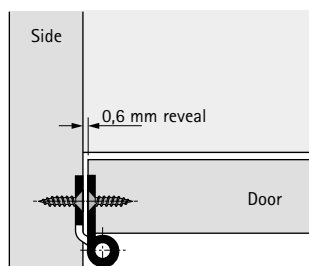

Fasten with countersunk wood screws  $\varnothing$  3 DIN 97

### Hinge length 40 mm

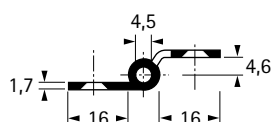
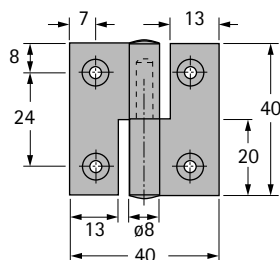

### Hinge length 50 mm

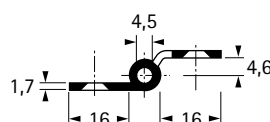
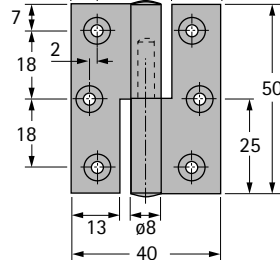

### Hinge length 60 mm

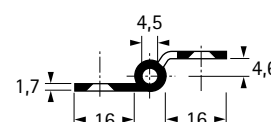
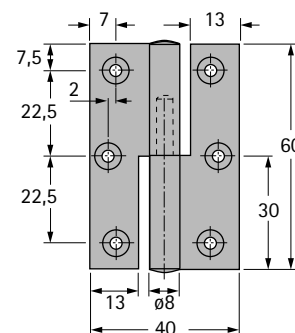

# Butt hinge 300 cranking D 7,5



## Specification

Hettich butt hinge 300, cranking D 7,5, from drawn brass, drilled and milled. Knuckle  $\varnothing$  8 mm, flap thickness 1,7 mm Countersunk holes

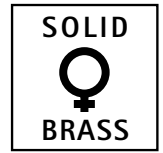

### Butt hinge for rebated doors Solid brass

Knuckle  $\varnothing$  8 mm, flap thickness 1,7 mm  
Drawn brass, drilled and milled, with steel pin and milled countersunk holes, without washer.



3

| Article                             | Finish                   | Hinge length 40 mm |        | Hinge length 50 mm |        | Hinge length 60 mm |        |
|-------------------------------------|--------------------------|--------------------|--------|--------------------|--------|--------------------|--------|
|                                     |                          | Order no.          | PU     | Order no.          | PU     | Order no.          | PU     |
| Butt hinge 300 left cranking D 7,5  | polished brass           | 031 929            | 10 pcs | 031 016            | 10 pcs | 031 921            | 10 pcs |
|                                     | matt brushed brass       | 042 289            | 10 pcs | 031 017            | 10 pcs | 031 922            | 10 pcs |
|                                     | high-gloss nickel-plated | 031 930            | 10 pcs | 031 018            | 10 pcs | 031 923            | 10 pcs |
|                                     | nickel-plated matt       | 031 931            | 10 pcs | 031 019            | 10 pcs | 031 924            | 10 pcs |
| Butt hinge 300 right cranking D 7,5 | polished brass           | 031 925            | 10 pcs | 031 020            | 10 pcs | 031 917            | 10 pcs |
|                                     | matt brushed brass       | 031 926            | 10 pcs | 031 021            | 10 pcs | 031 918            | 10 pcs |
|                                     | high-gloss nickel-plated | 031 927            | 10 pcs | 031 022            | 10 pcs | 042 290            | 10 pcs |
|                                     | nickel-plated matt       | 031 928            | 10 pcs | 031 023            | 10 pcs | 031 919            | 10 pcs |

### Mounting example

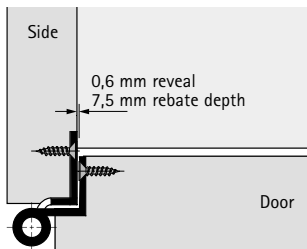

Fasten with countersunk wood screws  $\varnothing$  3 DIN 97

### Hinge length 40 mm

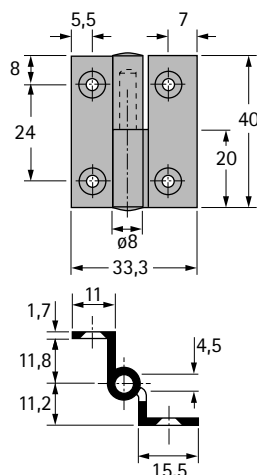

### Hinge length 50 mm

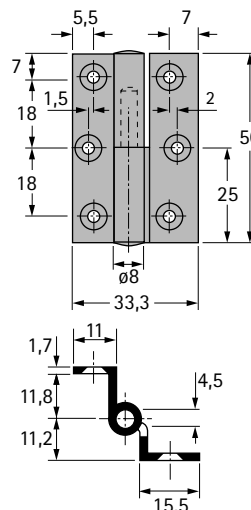

### Hinge length 60 mm

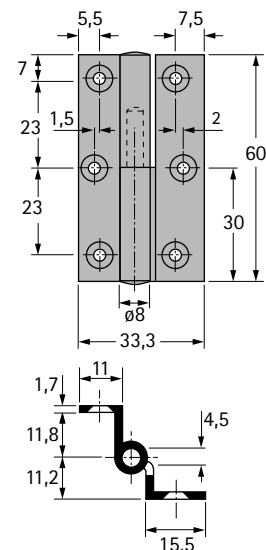

# Butt hinge 260 straight



## Specification

Hettich butt hinge 260, straight,  
from drawn brass,  
drilled and milled.  
Knuckle  $\varnothing$  6 mm, flap thickness 1,7 mm

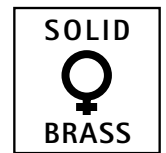

### Butt hinge for inset doors Solid brass

Knuckle  $\varnothing$  6 mm, flap thickness 1,7 mm  
Drawn brass, drilled and milled,  
with steel pin and washer.

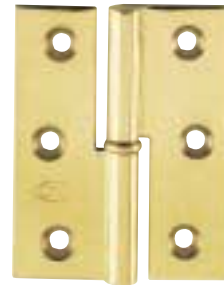

3

| Article                          | Finish                   | Order no. | PU     |
|----------------------------------|--------------------------|-----------|--------|
| Butt hinge 260 left<br>straight  | polished brass           | 042 413   | 20 pcs |
|                                  | matt brushed brass       | 042 414   | 20 pcs |
|                                  | nickel-plated matt       | 042 415   | 20 pcs |
|                                  | high-gloss nickel-plated | 042 416   | 20 pcs |
| Butt hinge 260 right<br>straight | polished brass           | 042 417   | 20 pcs |
|                                  | matt brushed brass       | 042 418   | 20 pcs |
|                                  | nickel-plated matt       | 042 419   | 20 pcs |
|                                  | high-gloss nickel-plated | 042 420   | 20 pcs |

## Mounting example

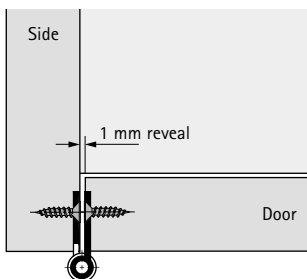

Fasten with countersunk  
wood screws  $\varnothing$  3 DIN 97

## Hinge length 50 mm

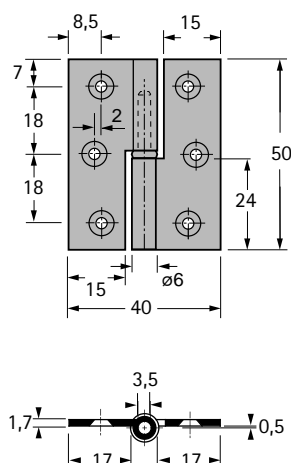

# Butt hinge 260 cranking B



## Specification

Hettich butt hinge 260, cranking B, from drawn brass, drilled and milled. Knuckle  $\varnothing$  6 mm, flap thickness 1,7 mm

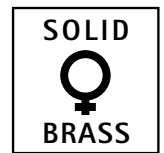

### Butt hinge for recessed doors Solid brass

Knuckle  $\varnothing$  6 mm, flap thickness 1,7 mm  
Drawn brass, drilled and milled, with steel pin and washer.

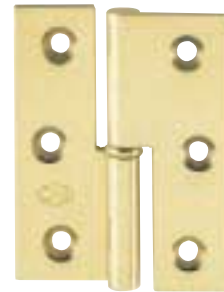

3

| Article                         | Finish                   | Order no. | PU     |
|---------------------------------|--------------------------|-----------|--------|
| Butt hinge 260 left cranking B  | polished brass           | 042 421   | 20 pcs |
|                                 | matt brushed brass       | 042 422   | 20 pcs |
|                                 | nickel-plated matt       | 042 423   | 20 pcs |
|                                 | high-gloss nickel-plated | 042 424   | 20 pcs |
| Butt hinge 260 right cranking B | polished brass           | 042 425   | 20 pcs |
|                                 | matt brushed brass       | 042 426   | 20 pcs |
|                                 | nickel-plated matt       | 042 451   | 20 pcs |
|                                 | high-gloss nickel-plated | 042 452   | 20 pcs |

### Mounting example

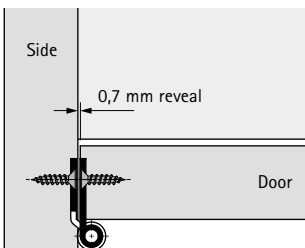

Fasten with countersunk wood screws  $\varnothing$  3 DIN 97

### Hinge length 50 mm

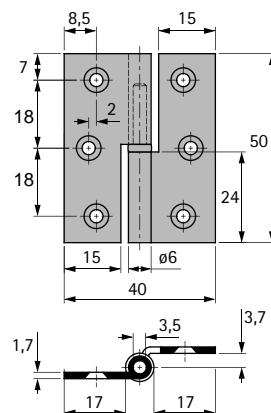

# Butt hinge 260 cranking D 7,5



## Specification

Hettich butt hinge 260, cranking D 7,5,  
from drawn brass,  
drilled and milled.  
Knuckle  $\varnothing$  6 mm, flap thickness 1,7 mm

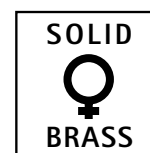

### Butt hinge for rebated doors

#### Solid brass

Knuckle  $\varnothing$  6 mm, flap thickness 1,7 mm  
Drawn brass, drilled and milled,  
with steel pin and washer.



3

| Article                                | Finish                   | Order no. | PU     |
|--|--------------------------|-----------|--------|
| Butt hinge 260 left<br>cranking D 7,5  | polished brass           | 042 453   | 20 pcs |
|  | matt brushed brass       | 042 454   | 20 pcs |
|  | nickel-plated matt       | 042 455   | 20 pcs |
|  | high-gloss nickel-plated | 042 456   | 20 pcs |
| Butt hinge 260 right<br>cranking D 7,5 | polished brass           | 042 457   | 20 pcs |
|  | matt brushed brass       | 042 458   | 20 pcs |
|  | nickel-plated matt       | 042 459   | 20 pcs |
|  | high-gloss nickel-plated | 042 460   | 20 pcs |

### Mounting example

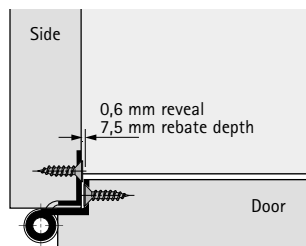

Fasten with countersunk  
wood screws  $\varnothing$  3 DIN 97

### Hinge length 50 mm

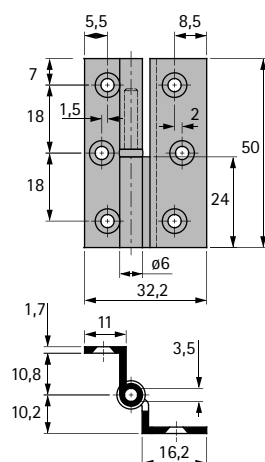

# Butt hinge 209 straight



## Specification

Hettich butt hinge 209, straight,  
from drawn brass,  
drilled and milled.  
Knuckle  $\varnothing$  11 mm, flap thickness 2 mm

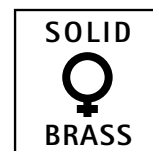

### Butt hinge for inset doors

#### Solid brass

Knuckle  $\varnothing$  8 mm, flap thickness 2 mm  
Drawn brass, drilled and milled,  
with steel pin and milled countersunk holes,  
without wash

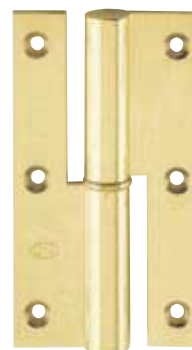

3

| Article                       | Finish                   | Order no. | PU     |
|-------------------------------|--------------------------|-----------|--------|
| Butt hinge 209 left straight  | polished brass           | 031 042   | 10 pcs |
|                               | nickel-plated matt       | 031 046   | 10 pcs |
|                               | high-gloss nickel-plated | 031 048   | 10 pcs |
| Butt hinge 209 right straight | polished brass           | 031 043   | 10 pcs |
|                               | nickel-plated matt       | 031 047   | 10 pcs |
|                               | high-gloss nickel-plated | 031 049   | 10 pcs |

### Mounting example

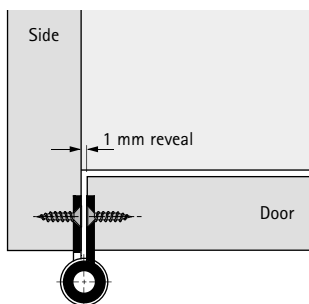

Fasten with countersunk  $\varnothing$  3  
DIN 97 wood screws

### Hinge length 80 mm

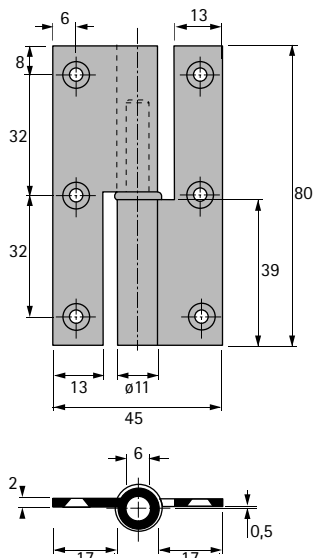

# Butt hinge 209 cranking B



## Specification

Hettich butt hinge 209, cranking B,  
from drawn brass,  
drilled and milled.  
Knuckle  $\varnothing$  11 mm, flap thickness 2 mm

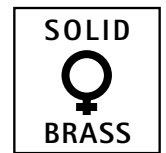

### Butt hinge for recessed doors Solid brass

Knuckle  $\varnothing$  11 mm, flap thickness 2 mm  
Drawn brass, drilled and milled,  
with steel pin and washer.



3

| Article                            | Finish                   | Order no. | PU     |
|------------------------------------|--------------------------|-----------|--------|
| Butt hinge 209 left<br>cranking B  | polished brass           | 031 050   | 10 pcs |
|                                    | nickel-plated matt       | 031 054   | 10 pcs |
|                                    | high-gloss nickel-plated | 031 056   | 10 pcs |
| Butt hinge 209 right<br>cranking B | polished brass           | 031 051   | 10 pcs |
|                                    | nickel-plated matt       | 031 055   | 10 pcs |
|                                    | high-gloss nickel-plated | 031 057   | 10 pcs |

## Mounting example

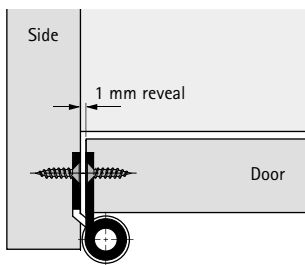

Fasten with countersunk  
wood screws  $\varnothing$  3 DIN 97

## Hinge length 80 mm

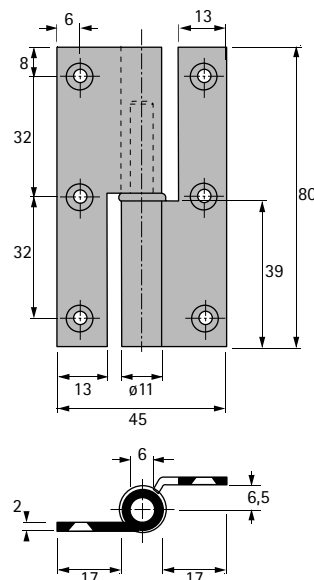

# Butt hinge 209 cranking D 7,5



## Specification

Hettich butt hinge 209, cranking D 7,5,  
from drawn brass,  
drilled and milled.  
Knuckle  $\varnothing$  11 mm, flap thickness 2 mm

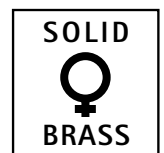

### Butt hinge for rebated doors Solid brass

Knuckle  $\varnothing$  11 mm, flap thickness 2 mm  
Drawn brass, drilled and milled,  
with steel pin and washer.



3

| Article                                | Finish                   | Order no. | PU     |
|--|--------------------------|-----------|--------|
| Butt hinge 209 left<br>cranking D 7,5  | polished brass           | 031 058   | 10 pcs |
|  | nickel-plated matt       | 031 062   | 10 pcs |
|  | high-gloss nickel-plated | 031 064   | 10 pcs |
| Butt hinge 209 right<br>cranking D 7,5 | polished brass           | 031 059   | 10 pcs |
|  | nickel-plated matt       | 031 063   | 10 pcs |
|  | high-gloss nickel-plated | 031 065   | 10 pcs |

### Mounting example

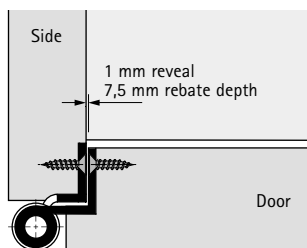

Fasten with countersunk  
wood screws  $\varnothing$  3 DIN 97

### Hinge length 80 mm

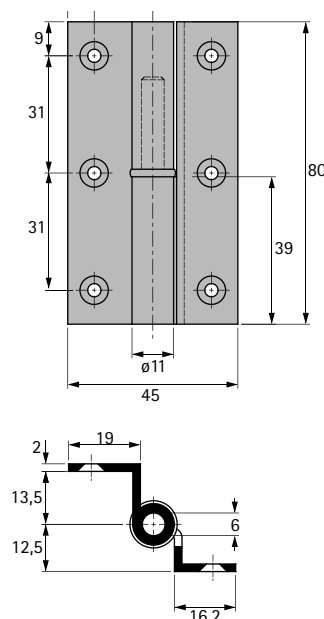

Technical information – see pages 3.214

# Finial butt hinge 230 straight



## Specification

Hettich finial butt hinge 230, straight, from drawn brass, drilled and milled.

Knuckle  $\varnothing$  8 mm, flap thickness 1,7 mm  
ZK 19 finials

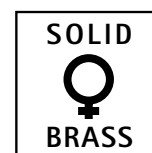

### Finial butt hinge for inset doors

#### Solid brass

Knuckle  $\varnothing$  8 mm, flap thickness 1,7 mm

Drawn brass, drilled and milled, with steel pin, washer and ZK 19 finials.



3

| Article                              | Finish                   | Hinge length 40 mm |        | Hinge length 50 mm |        | Hinge length 60 mm |        |
|--------------------------------------|--------------------------|--------------------|--------|--------------------|--------|--------------------|--------|
|                                      |                          | Order no.          | PU     | Order no.          | PU     | Order no.          | PU     |
| Finial butt hinge 230 left straight  | polished brass           | 042 030            | 10 pcs | 031 024            | 10 pcs | 042 062            | 10 pcs |
|                                      | brown-coloured           | 042 031            | 10 pcs | 031 026            | 10 pcs | 042 063            | 10 pcs |
|                                      | Roller brushed (antique) |                    |        |                    |        |                    |        |
| Finial butt hinge 230 right straight | polished brass           | 042 291            | 10 pcs | 031 027            | 10 pcs | 042 065            | 10 pcs |
|                                      | brown-coloured           | 042 033            | 10 pcs | 031 029            | 10 pcs | 042 066            | 10 pcs |
|                                      | Roller brushed (antique) |                    |        |                    |        |                    |        |

### Mounting example

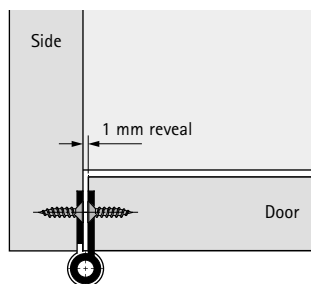

Fasten with countersunk wood screws  $\varnothing$  3 DIN 97

### Hinge length 40 mm

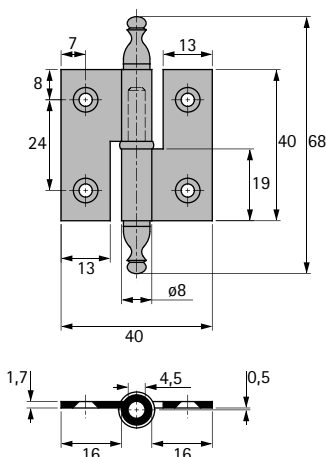

### Hinge length 50 mm

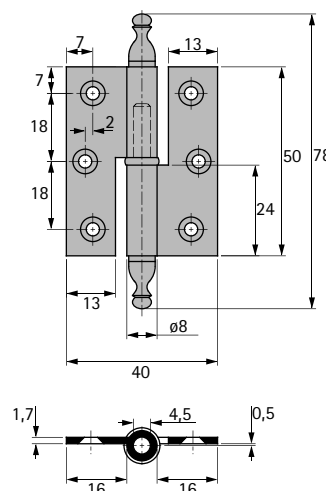

### Hinge length 60 mm

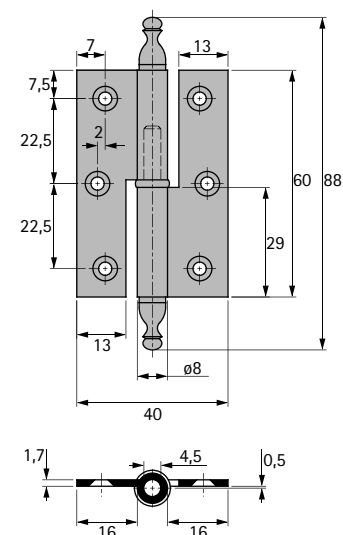

# Finial butt hinge 230 cranking B



## Specification

Hettich finial butt hinge 230, cranking B, from drawn brass, drilled and milled. Knuckle  $\varnothing$  8 mm, flap thickness 1,7 mm ZK 19 finials

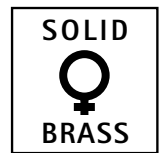

### Finial butt hinge for recessed doors Solid brass

Knuckle  $\varnothing$  8 mm, flap thickness 1,7 mm  
Drawn brass, drilled and milled, with steel pin, washer and ZK 19 finials.

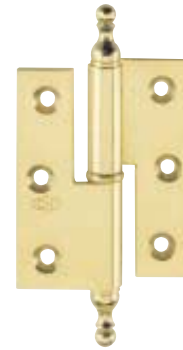

3

| Article                                | Finish                   | Hinge length 40 mm |        | Hinge length 50 mm |        | Hinge length 60 mm |        |
|--|--------------------------|--------------------|--------|--------------------|--------|--------------------|--------|
|  |                          | Order no.          | PU     | Order no.          | PU     | Order no.          | PU     |
| Finial butt hinge 230 left cranking B  | polished brass           | 042 293            | 10 pcs | 031 030            | 10 pcs | 042 055            | 10 pcs |
|  | brown-coloured           | 042 027            | 10 pcs | 031 032            | 10 pcs | 042 057            | 10 pcs |
|  | Roller brushed (antique) |                    |        |                    |        |                    |        |
| Finial butt hinge 230 right cranking B | polished brass           | 042 294            | 10 pcs | 031 033            | 10 pcs | 042 296            | 10 pcs |
|  | brown-coloured           | 042 295            | 10 pcs | 031 035            | 10 pcs | 042 297            | 10 pcs |
|  | Roller brushed (antique) |                    |        |                    |        |                    |        |

### Mounting example

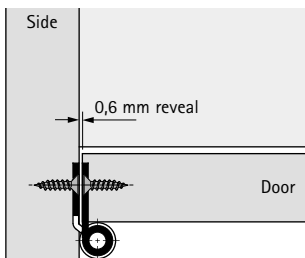

Fasten with countersunk  $\varnothing$  3 DIN 97 wood screws

### Hinge length 40 mm

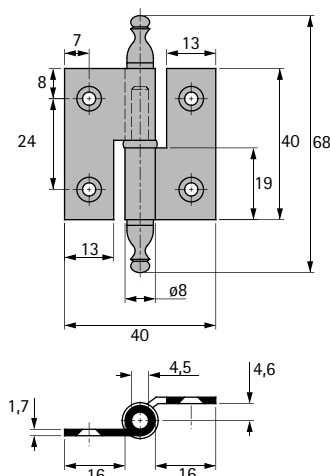

### Hinge length 50 mm

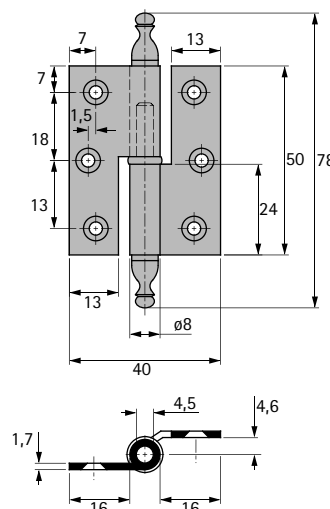

### Hinge length 60 mm

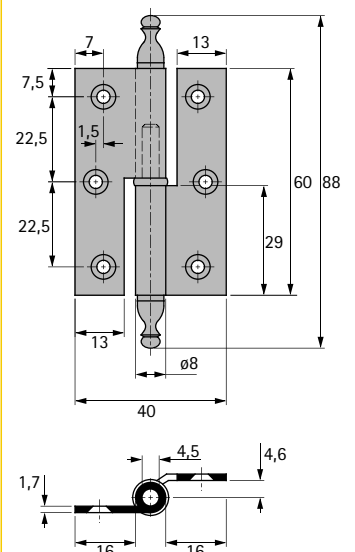

Technical information – see pages 3.214

# Finial butt hinge 230 cranking D 7,5



## Specification

Hettich finial butt hinge 230, cranking D 7,5, from drawn brass, drilled and milled.

Knuckle  $\varnothing$  8 mm, flap thickness 1,7 mm  
ZK 19 finials

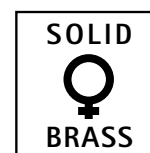

### Finial butt hinge for rebated doors

**Solid brass**

Knuckle  $\varnothing$  8 mm, flap thickness 1,7 mm

Drawn brass, drilled and milled, with steel pin, washer and ZK 19 finials.



3

| Article                                    | Finish                                     | Hinge length 40 mm |        | Hinge length 50 mm |        | Hinge length 60 mm |        |
|--|--|--------------------|--------|--------------------|--------|--------------------|--------|
|  |  | Order no.          | PU     | Order no.          | PU     | Order no.          | PU     |
| Finial butt hinge 230 left cranking D 7,5  | polished brass                             | 042 016            | 10 pcs | 031 036            | 10 pcs | 042 036            | 10 pcs |
|  | brown-coloured<br>Roller brushed (antique) | 042 018            | 10 pcs | 031 038            | 10 pcs | 042 038            | 10 pcs |
| Finial butt hinge 230 right cranking D 7,5 | polished brass                             | 042 298            | 10 pcs | 031 039            | 10 pcs | 042 040            | 10 pcs |
|  | brown-coloured<br>Roller brushed (antique) | 042 021            | 10 pcs | 031 041            | 10 pcs | 042 042            | 10 pcs |

### Mounting example

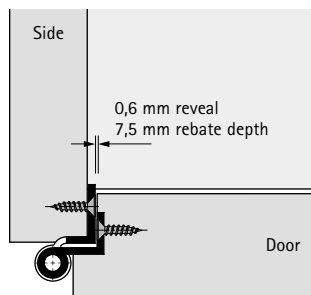

Fasten with countersunk wood screws  $\varnothing$  3 DIN 97

### Hinge length 40 mm

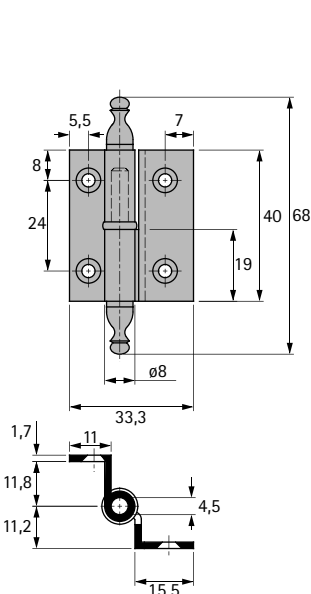

### Hinge length 50 mm

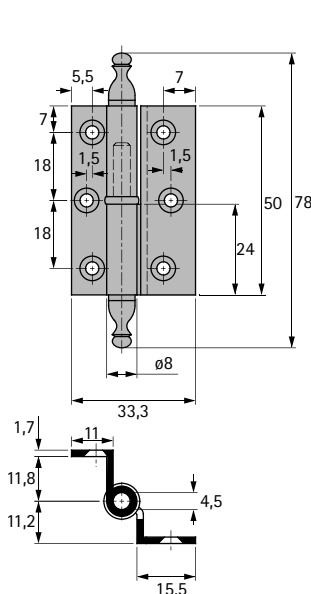

### Hinge length 60 mm

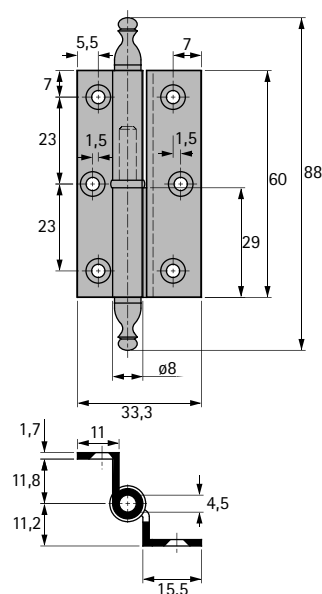

## Programme overview

|   |       |               |
|---|-------|---------------|
| <b>Butt hinges</b>                            | Pages | 3.210 – 3.219 |
| <b>Finial butt hinges</b>                     | Pages | 3.220 – 3.228 |
| <b>Cranked butt hinges</b>                    | Pages | 3.229         |
| <b>Wide-angle hinges</b>                      | Pages | 3.230         |
| <b>Mortised hinges</b>                        | Pages | 3.231         |
| <b>Flush hinges</b>                           | Pages | 3.232 – 3.234 |
| <b>Narrow hinges</b>                          | Page  | 3.235         |
| <b>Square hinges</b>                          | Page  | 3.236         |
| <b>Wide hinges</b>                            | Page  | 3.237         |
| <b>Surface hinges</b>                         | Pages | 3.238 – 3.245 |
| <b>Piano hinges</b>                           | Pages | 3.246 – 3.247 |
| <b>Pivot hinges</b>                           | Pages | 3.248 – 3.249 |
| <b>Pivot hinge double swing door fittings</b> | Pages | 3.250 – 3.251 |
| <b>Flap hinges for cup drilling</b>           | Pages | 3.252 – 3.256 |
| <b>Flap hinges for flush fixing</b>           | Pages | 3.257 – 3.258 |
| <b>Special-purpose hinges/table hinges</b>    | Pages | 3.259 – 3.264 |
| <b>Top box stays/hinges</b>                   | Pages | 3.265 – 3.283 |
| <b>Vertical lift-up flap fittings</b>         | Pages | 3.284 – 3.293 |
| <b>Vertical lift-up flap fitting</b>          | Pages | 3.294 – 3.299 |
| <b>Fold-lift fitting</b>                      | Pages | 3.300 – 3.301 |
| <b>Swivel fitting Horizon Plus</b>            | Pages | 3.302 – 3.309 |

# Finial butt hinge 270 straight



## Specification

Hettich finial butt hinge 270, straight, from drawn brass, drilled and milled. Knuckle  $\varnothing$  6 mm, flap thickness 1,7 mm ZK 19 finials

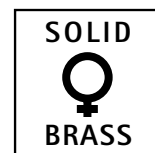

### Finial butt hinge for inset doors

#### Solid brass

Knuckle  $\varnothing$  6 mm, flap thickness 1,7 mm Drawn brass, drilled and milled, with steel pin, washer and ZK 19 finials.



3

| Article                              | Finish                                     | Order no. | PU     |
|--------------------------------------|--|-----------|--------|
| Finial butt hinge 270 left straight  | polished brass                             | 042 008   | 20 pcs |
|                                      | brown-coloured<br>Roller brushed (antique) | 042 010   | 20 pcs |
| Finial butt hinge 270 right straight | polished brass                             | 042 012   | 20 pcs |
|                                      | brown-coloured<br>Roller brushed (antique) | 042 014   | 20 pcs |

## Mounting example

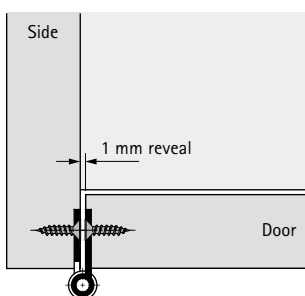

## Hinge length 50 mm

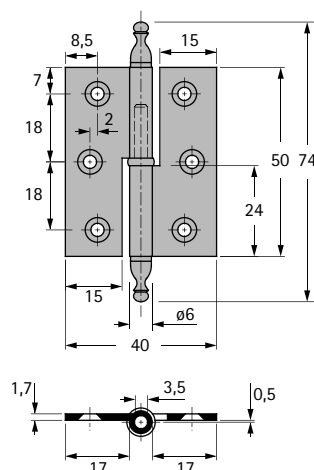

Fasten with countersunk wood screws  $\varnothing$  3 DIN 97

Technical information – see pages 3.214

# Finial butt hinge 270 cranking B



## Specification

Hettich finial butt hinge 270, cranking B, from drawn brass, drilled and milled. Knuckle  $\varnothing$  6 mm, flap thickness 1,7 mm ZK 19 finials

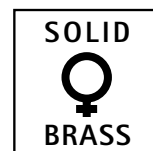

### Finial butt hinge for recessed doors

#### Solid brass

Knuckle  $\varnothing$  6 mm, flap thickness 1,7 mm  
Drawn brass, drilled and milled, with steel pin, washer and ZK 19 finials.

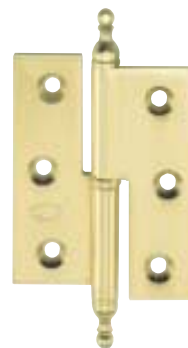

3

| Article                                | Finish                                     | Order no. | PU     |
|--|--|-----------|--------|
| Finial butt hinge 270 left cranking B  | polished brass                             | 031 999   | 20 pcs |
|  | brown-coloured<br>Roller brushed (antique) | 042 000   | 20 pcs |
| Finial butt hinge 270 right cranking B | polished brass                             | 042 002   | 20 pcs |
|  | brown-coloured<br>Roller brushed (antique) | 042 003   | 20 pcs |

### Mounting example

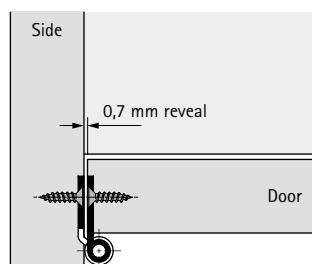

Fasten with countersunk wood screws  $\varnothing$  3 DIN 97

### Hinge length 50 mm

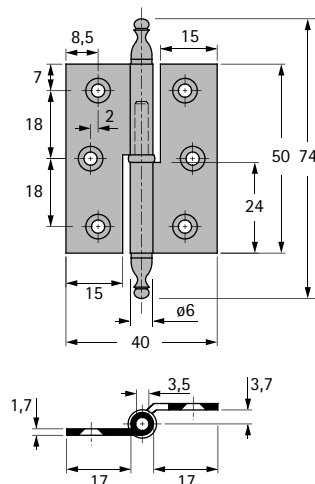

# Finial butt hinge 270 cranking D 7,5



## Specification

Hettich finial butt hinge 270, cranking D 7,5, from drawn brass, drilled and milled. Knuckle  $\varnothing$  6 mm, flap thickness 1,7 mm ZK 19 finials

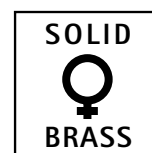

### Finial butt hinge for rebated doors

#### Solid brass

Knuckle  $\varnothing$  6 mm, flap thickness 1,7 mm  
 Drawn brass, drilled and milled, with steel pin, washer and ZK 19 finials.

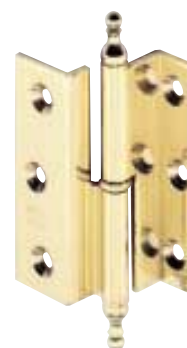

| Article                                    | Finish                                     | Order no. | PU     |
|--|--|-----------|--------|
| Finial butt hinge 270 left cranking D 7,5  | polished brass                             | 031 987   | 20 pcs |
|  | brown-coloured<br>Roller brushed (antique) | 042 302   | 20 pcs |
| Finial butt hinge 270 right cranking D 7,5 | polished brass                             | 031 990   | 20 pcs |
|  | brown-coloured<br>Roller brushed (antique) | 031 992   | 20 pcs |

### Mounting example

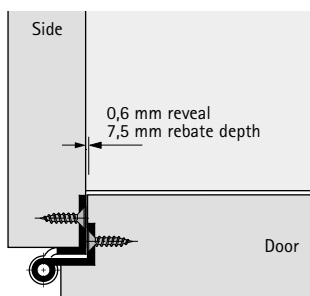

Fasten with countersunk wood screws  $\varnothing$  3 DIN 97

### Hinge length 50 mm

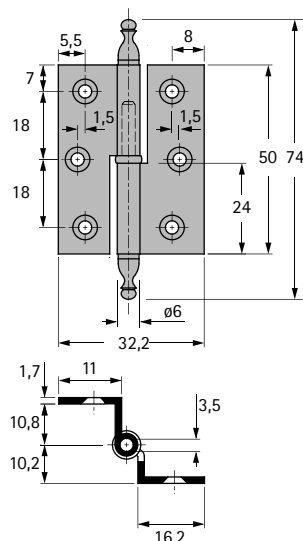

# Finial butt hinge 212 straight



## Specification

Hettich finial butt hinge 212, straight, from drawn brass, drilled and milled. Knuckle  $\varnothing$  11 mm, flap thickness 2 mm ZK 19 finials

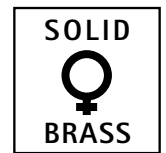

### Finial butt hinge for inset doors Solid brass

Knuckle  $\varnothing$  11 mm, flap thickness 2 mm  
Drawn brass, drilled and milled, with steel pin, washer and ZK 19 finials.



3

| Article                              | Finish                   | Order no. | PU     |
|--------------------------------------|--------------------------|-----------|--------|
| Finial butt hinge 212 left straight  | polished brass           | 031 066   | 10 pcs |
|                                      | brown-coloured           | 031 068   | 10 pcs |
|                                      | Roller brushed (antique) |           |        |
| Finial butt hinge 212 right straight | polished brass           | 031 067   | 10 pcs |
|                                      | brown-coloured           | 031 069   | 10 pcs |
|                                      | Roller brushed (antique) |           |        |

### Mounting example

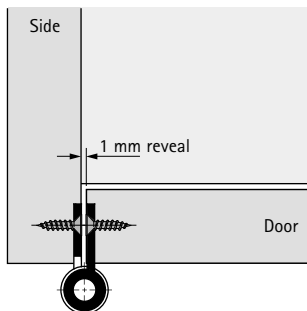

### Hinge length 80 mm

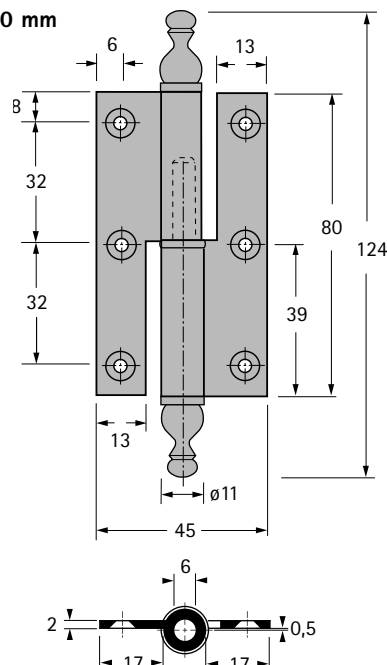

Fasten with countersunk wood screws  $\varnothing$  3 DIN 97

# Finial butt hinge 212 cranking B



## Specification

Hettich finial butt hinge 212, cranking B, from drawn brass, drilled and milled.  
Knuckle  $\varnothing$  11 mm, flap thickness 2 mm  
ZK 19 finials

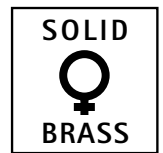

### Finial butt hinge for recessed doors Solid brass

Knuckle  $\varnothing$  11 mm, flap thickness 2 mm  
Drawn brass, drilled and milled, with steel pin, washer and ZK 19 finials.



3

| Article                                | Finish                                     | Order no. | PU     |
|--|--|-----------|--------|
| Finial butt hinge 212 left cranking B  | polished brass                             | 031 070   | 10 pcs |
|  | brown-coloured<br>Roller brushed (antique) | 031 072   | 10 pcs |
| Finial butt hinge 212 right cranking B | polished brass                             | 031 071   | 10 pcs |
|  | brown-coloured<br>Roller brushed (antique) | 031 073   | 10 pcs |

### Mounting example

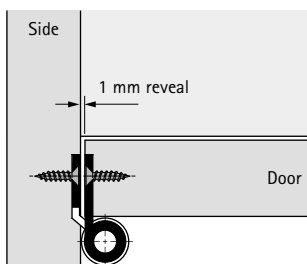

### Hinge length 80 mm

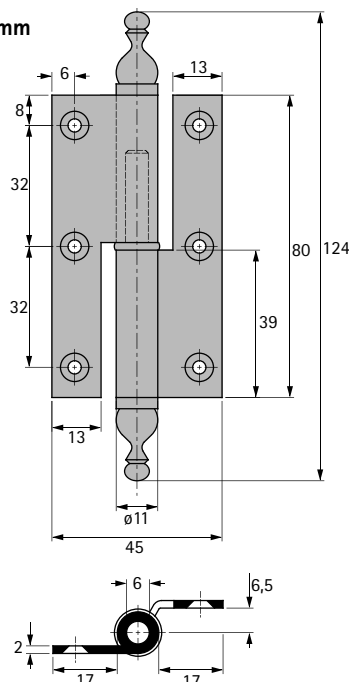

Fasten with countersunk wood screws  $\varnothing$  3 DIN 97

Technical information – see pages 3.214

# Finial butt hinge 212 cranking D 7,5



## Specification

Hettich finial butt hinge 212,  
cranking D 7,5, from drawn brass,  
drilled and milled.  
Knuckle  $\varnothing$  11 mm, flap thickness 2 mm  
ZK 19 finials

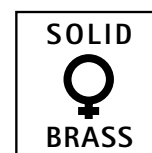

### Finial butt hinge for rebated doors

#### Solid brass

Knuckle  $\varnothing$  11 mm, flap thickness 2 mm  
Drawn brass, drilled and milled,  
with steel pin, washer and ZK 19 finials.



3

| Article                                       | Finish                   | Order no. | PU     |
|---|--------------------------|-----------|--------|
| Finial butt hinge 212 left<br>cranking D 7,5  | polished brass           | 031 074   | 10 pcs |
|   | brown-coloured           | 031 076   | 10 pcs |
|   | Roller brushed (antique) |           |        |
| Finial butt hinge 212 right<br>cranking D 7,5 | polished brass           | 031 075   | 10 pcs |
|   | brown-coloured           | 031 077   | 10 pcs |
|   | Roller brushed (antique) |           |        |

### Mounting example

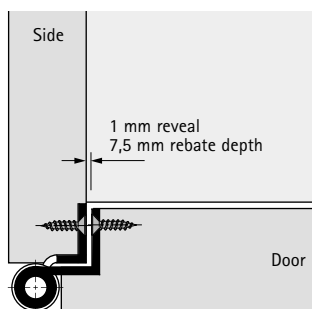

Fasten with countersunk  
wood screws  $\varnothing$  3 DIN 97

### Hinge length 80 mm

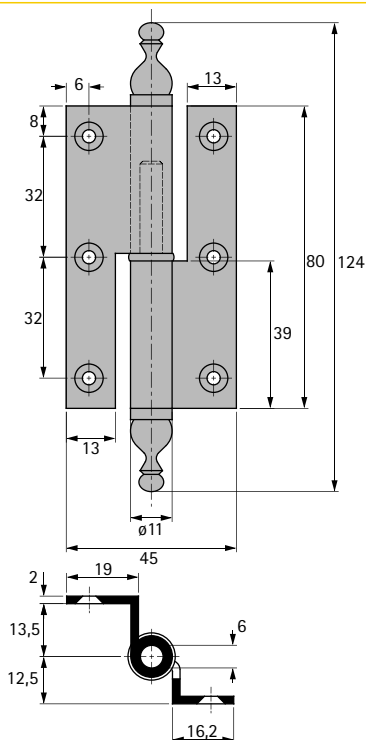

# Cranked butt hinge 700

## Specification

Hettich cranked butt hinge 700, from drawn brass, drilled and milled

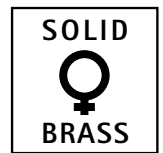

### Cranked butt hinge for overlay doors Solid brass

Drawn brass, drilled and milled, with steel pin, without washer.  
Opening angle 270°



3

| Article                      | Finish                   | Door thickness 16 - 17 mm |    | Door thickness 18 - 20 mm |    | Door thickness 20 - 21 mm |    | Door thickness 22 - 23 mm |    |
|------------------------------|--------------------------|---------------------------|----|---------------------------|----|---------------------------|----|---------------------------|----|
|                              |                          | Order no.                 | PU | Order no.                 | PU | Order no.                 | PU | Order no.                 | PU |
| Cranked butt hinge 700 left  | polished brass           | 031 890                   | 10 | 031 090                   | 10 | 042 795                   | 10 | 031 862                   | 10 |
|                              | high-gloss nickel-plated | 031 892                   | 10 | 031 092                   | 10 | -                         | -  | 031 863                   | 10 |
|                              | nickel-plated matt       | 031 893                   | 10 | 031 093                   | 10 | 042 798                   | 10 | 031 864                   | 10 |
| Cranked butt hinge 700 right | polished brass           | 031 886                   | 10 | 031 094                   | 10 | 042 799                   | 10 | 031 874                   | 10 |
|                              | high-gloss nickel-plated | 031 888                   | 10 | 031 096                   | 10 | -                         | -  | 031 860                   | 10 |
|                              | nickel-plated matt       | 031 889                   | 10 | 031 097                   | 10 | 042 802                   | 10 | 031 861                   | 10 |

### Mounting example

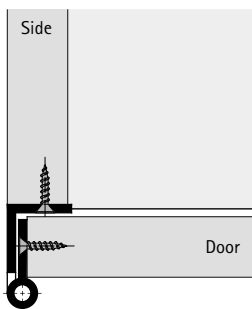

Fasten with countersunk wood screws  $\varnothing$  3 DIN 97

#### Door thickness 16 - 17 mm

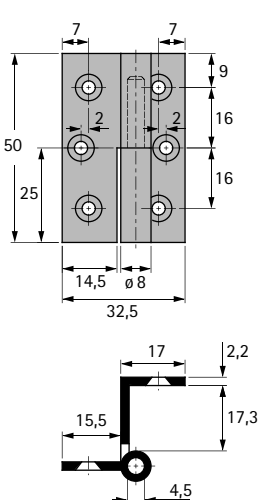

#### Door thickness 18 - 20 mm

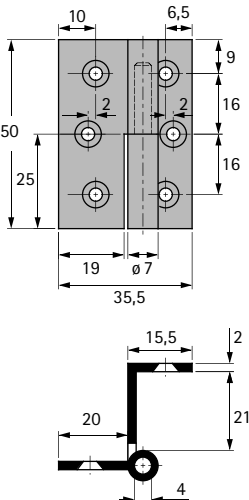

#### Door thickness 20 - 21 mm

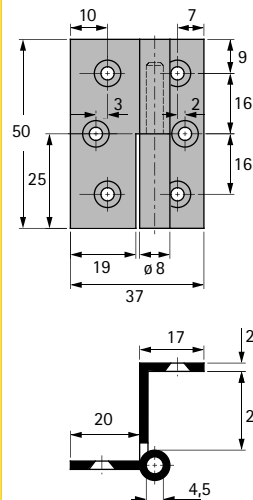

#### Door thickness 22 - 23 mm

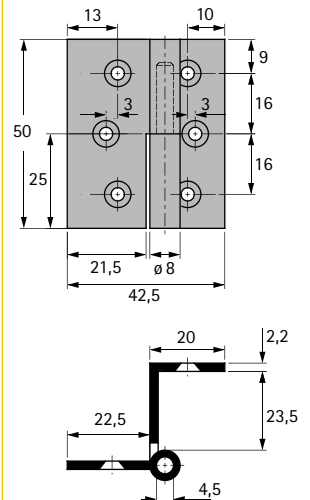

# Cranked flush hinge 4162

## Specification

Hettich cranked flush hinge 4162,  
from drawn brass,  
drilled and milled,  
with fixed stainless steel pin

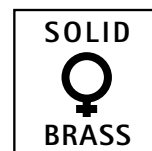

**Cranked flush hinge  
for overlay doors**  
Door thickness 16-20 mm  
Solid brass

Drawn brass, drilled and milled,  
with fixed stainless steel pin.  
Opening angle 220°

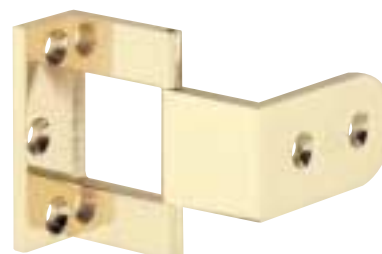

3

| Article                  | Finish                   | Order no. | PU     |
|--------------------------|--------------------------|-----------|--------|
| Cranked flush hinge 4162 | polished brass           | 042 592   | 10 pcs |
|                          | high-gloss nickel-plated | 042 593   | 10 pcs |

### Mounting example

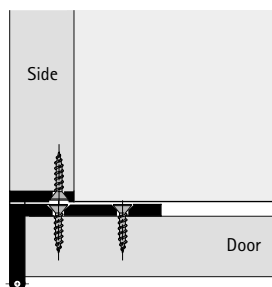

Fasten with countersunk  
wood screws  $\varnothing$  3 DIN 97

### Door thickness 16 - 20 mm

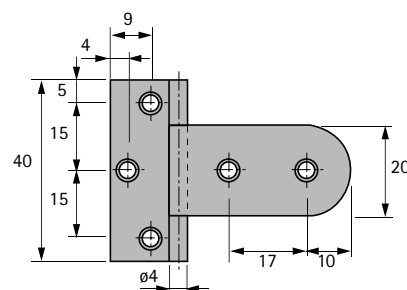
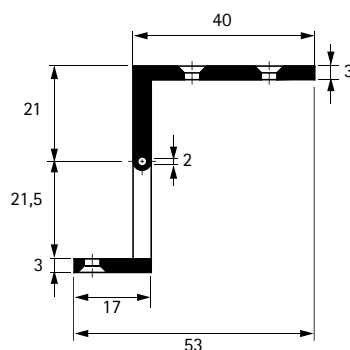

# Mortise hinge 32

## Specification

Hettich mortise hinge 32  
for rebated doors,  
from drawn brass

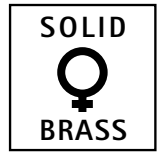

### Mortise hinge for rebated doors Solid brass

Knuckle  $\varnothing$  8 mm and 10 mm offset flaps.

Drawn brass, drilled and milled, with steel pin, washer and ZK 19 finials.



3

| Article                   | Finish   | Hinge length 80 mm<br>Knuckle- $\varnothing$ 8 mm |       | Hinge length 120 mm<br>Knuckle- $\varnothing$ 10 mm |       |
|---------------------------|--|---|-------|---|-------|
|                           |  | Order no.   | PU    | Order no.   | PU    |
| Mortise hinge 32<br>left  | polished brass<br>brown-coloured<br>Roller brushed (antique) | 031 078   | 2 pcs | 031 084   | 2 pcs |
|                           |  | 031 080   | 2 pcs | -   | -     |
| Mortise hinge 32<br>right | polished brass<br>brown-coloured<br>Roller brushed (antique) | 031 081   | 2 pcs | 031 087   | 2 pcs |
|                           |  | 031 083   | 2 pcs | -   | -     |

### Mounting example

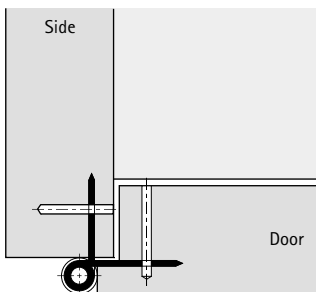

Fasten with pins  
 $\varnothing$  3 mm, hinge length 80 mm  
 $\varnothing$  3,5 mm, hinge length 120 mm

### Hinge length 80 mm

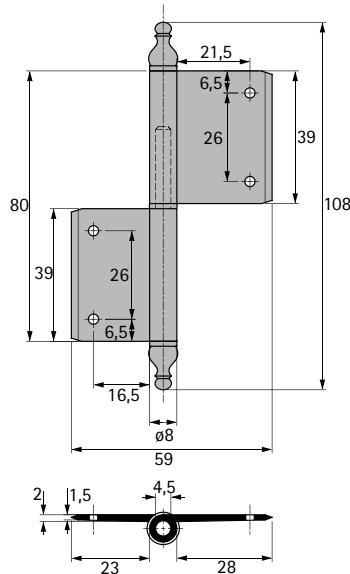

### Hinge length 120 mm

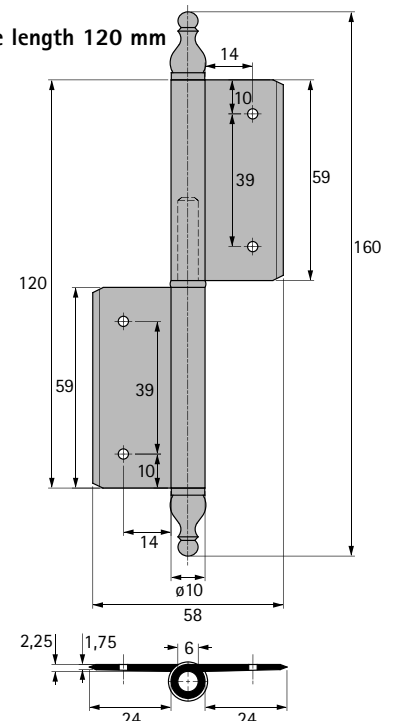

# Butt hinge 100



## Specification

Hettich butt hinge 100  
from drawn brass,  
drilled and milled,  
with fixed brass pin.

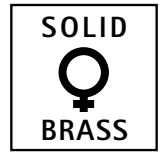

3



**Butt hinge 100  
Solid brass version**  
Drawn brass, drilled and milled,  
with fixed brass pin.



| Article                        | Finish                   | Order no. | PU     |
|--------------------------------|--------------------------|-----------|--------|
| Butt hinge 100<br>Size 20 x 16 | smooth-polished brass    | 042 590   | 20 pcs |
|                                | polished brass           | 042 591   | 20 pcs |
|                                | matt brushed brass       | 042 634   | 20 pcs |
|                                | high-gloss nickel-plated | 042 635   | 20 pcs |
|                                | nickel-plated matt       | 042 636   | 20 pcs |

| Size<br>a x b | d1<br>mm | d2<br>mm | S1<br>mm | S2<br>mm | Screw<br>holes | DIN 97<br>Ø |
|---------------|----------|----------|----------|----------|----------------|-------------|
| 20 x 16       | 3,5      | 2,0      | 1,3      | 1,0      | 4              | 2,0         |

For other brass hinges 100 see page 3.237

### Mounting example

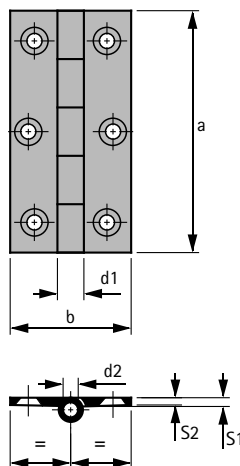
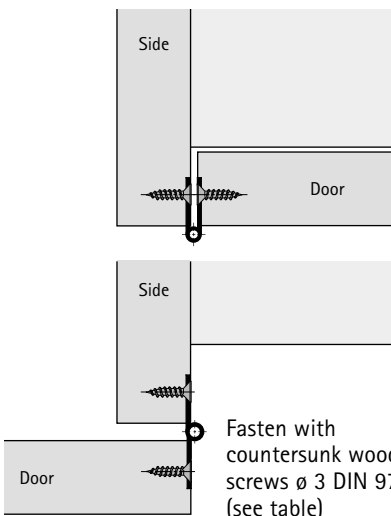

| Size    | Finish                   | Order no. | PU     |
|---------|--------------------------|-----------|--------|
| 25 x 20 | smooth-polished brass    | 031 102   | 20 pcs |
|         | polished brass           | 042 544   |        |
|         | high-gloss nickel-plated | 042 641   |        |
|         | high-gloss chrome-plated | 042 643   |        |
| 30 x 20 | smooth-polished brass    | 042 247   | 20 pcs |
|         | polished brass           | 042 545   |        |
|         | high-gloss nickel-plated | 042 647   |        |
|         | nickel-plated matt       | 042 648   |        |
|         | high-gloss chrome-plated | 042 649   |        |
| 40 x 20 | smooth-polished brass    | 042 337   | 20 pcs |
|         | polished brass           | 042 546   |        |
|         | high-gloss nickel-plated | 042 653   |        |
|         | nickel-plated matt       | 042 654   |        |
| 30 x 30 | smooth-polished brass    | 042 250   | 10 pcs |
|         | polished brass           | 042 547   |        |
|         | nickel-plated matt       | 042 660   |        |
| 40 x 30 | smooth-polished brass    | 031 103   | 10 pcs |
|         | polished brass           | 042 548   |        |
|         | matt brushed brass       | 042 664   |        |
|         | high-gloss nickel-plated | 042 665   |        |
|         | nickel-plated matt       | 042 666   |        |
|         | high-gloss chrome-plated | 042 667   |        |
|         | brown-coloured           | 042 669   |        |
| 50 x 30 | smooth-polished brass    | 042 252   | 10 pcs |
|         | polished brass           | 042 549   |        |
|         | matt brushed brass       | 042 670   |        |
|         | high-gloss nickel-plated | 042 671   |        |
|         | nickel-plated matt       | 042 672   |        |
|         | high-gloss chrome-plated | 042 673   |        |
| 40 x 40 | smooth-polished brass    | 042 255   | 10 pcs |
|         | polished brass           | 042 550   |        |
|         | matt brushed brass       | 042 676   |        |
|         | nickel-plated matt       | 042 678   |        |
|         | high-gloss chrome-plated | 042 679   |        |
|         | matt chrome-plated       | 042 680   |        |

| Size      | Finish                   | Order no. | PU     |
|-----------|--------------------------|-----------|--------|
| 50 x 40   | smooth-polished brass    | 031 104   | 10 pcs |
|           | polished brass           | 042 551   |        |
|           | matt brushed brass       | 042 682   |        |
|           | high-gloss nickel-plated | 042 683   |        |
|           | nickel-plated matt       | 042 684   |        |
|           | high-gloss chrome-plated | 042 685   |        |
|           | matt chrome-plated       | 042 686   |        |
| 60 x 40   | smooth-polished brass    | 031 105   | 10 pcs |
|           | polished brass           | 042 552   |        |
|           | matt brushed brass       | 042 688   |        |
|           | high-gloss nickel-plated | 042 689   |        |
|           | nickel-plated matt       | 042 690   |        |
|           | high-gloss chrome-plated | 042 691   |        |
| 50 x 50   | smooth-polished brass    | 042 258   | 10 pcs |
|           | polished brass           | 042 553   |        |
|           | nickel-plated matt       | 042 696   |        |
|           | high-gloss chrome-plated | 042 697   |        |
| 60 x 50   | smooth-polished brass    | 042 259   | 10 pcs |
|           | polished brass           | 042 554   |        |
|           | high-gloss nickel-plated | 042 701   |        |
|           | nickel-plated matt       | 042 702   |        |
|           | high-gloss chrome-plated | 042 703   |        |
| 80 x 50   | smooth-polished brass    | 042 338   | 10 pcs |
|           | polished brass           | 042 555   |        |
|           | high-gloss nickel-plated | 042 707   |        |
|           | nickel-plated matt       | 042 708   |        |
| 80 x 60   | smooth-polished brass    | 042 709   | 10 pcs |
|           | polished brass           | 031 106   |        |
|           | matt brushed brass       | 042 556   |        |
|           | high-gloss nickel-plated | 042 712   |        |
|           | nickel-plated matt       | 042 713   |        |
| 100 x 100 | smooth-polished brass    | 042 714   | 10 pcs |
|           | polished brass           | 042 718   |        |
|           | nickel-plated matt       | 042 719   |        |
|           |                          | 042 722   |        |

| Size a x b | d1 mm | d2 mm | S1 mm | S2 mm | Screw holes | DIN 97 ø |
|------------|-------|-------|-------|-------|-------------|----------|
| 25 x 20    | 4,0   | 2,5   | 1,5   | 1,2   | 4           | 2,5      |
| 30 x 20    | 4,0   | 2,5   | 1,5   | 1,2   | 4           | 2,5      |
| 40 x 20    | 4,0   | 2,5   | 1,5   | 1,2   | 4           | 2,5      |
| 30 x 30    | 4,0   | 2,5   | 1,5   | 1,2   | 4           | 3,0      |
| 40 x 30    | 4,0   | 2,5   | 1,5   | 1,2   | 4           | 3,0      |
| 50 x 30    | 4,5   | 2,5   | 1,8   | 1,5   | 4           | 3,0      |
| 40 x 40    | 4,5   | 2,5   | 1,8   | 1,5   | 4           | 3,0      |

| Size a x b | d1 mm | d2 mm | S1 mm | S2 mm | Screw holes | DIN 97 ø |
|------------|-------|-------|-------|-------|-------------|----------|
| 50 x 40    | 4,5   | 2,5   | 1,8   | 1,5   | 6           | 3,0      |
| 60 x 40    | 5,5   | 3,0   | 2,25  | 1,75  | 6           | 3,5      |
| 50 x 50    | 5,0   | 3,0   | 2,0   | 1,5   | 6           | 3,0      |
| 60 x 50    | 5,0   | 3,0   | 2,0   | 1,5   | 6           | 3,0      |
| 80 x 50    | 6,5   | 3,5   | 2,5   | 2,0   | 6           | 3,5      |
| 80 x 60    | 6,0   | 3,5   | 2,5   | 2,0   | 6           | 3,5      |
| 100 x 100  | 8,0   | 4,0   | 2,75  | 2,25  | 8           | 4,5      |

# Flush hinge 101

## Screw-on version



### Specification

Hettich flush hinge 101  
Screw-on version, adjustable in two dimensions,  
from drawn brass,  
drilled and milled,  
with fixed brass pin.

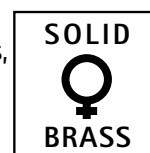

### Flush hinge 101 Solid brass

Drawn brass, drilled and milled,  
with fixed brass pin  
Adjustable in two dimensions  
Height:  $\pm 1$  mm  
Depth:  $\pm 1,5$  mm

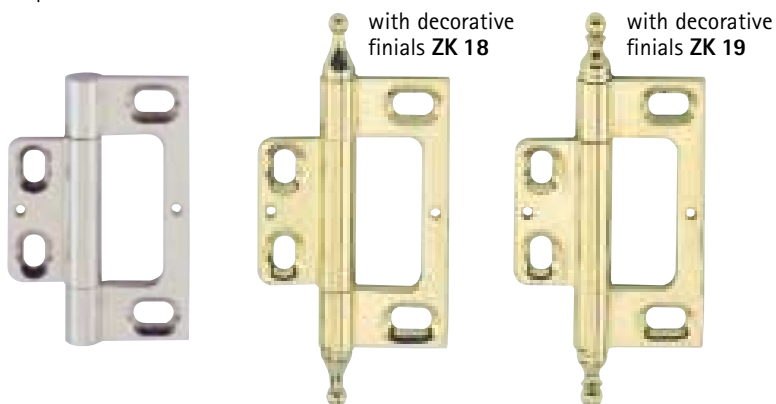

3

| Article         | Finish             | Hinge length 50 mm         |                               | Hinge length 75 mm         |                               | PU     |
|-----------------|--------------------|----------------------------|-------------------------------|----------------------------|-------------------------------|--------|
|                 |                    | without decorative finials | with decorative finials ZK 18 | without decorative finials | with decorative finials ZK 19 |        |
|                 |                    | Order no.                  | Order no.                     | Order no.                  | Order no.                     |        |
| Flush hinge 101 | polished brass     | 079 405                    | 079 408                       | 079 411                    | 079 414                       | 10 pcs |
|                 | nickel-plated matt | 079 406                    | 079 409                       | 079 412                    | 079 415                       | 10 pcs |
|                 | black              | 079 407                    | 079 410                       | 079 413                    | 079 416                       | 10 pcs |

### Mounting example

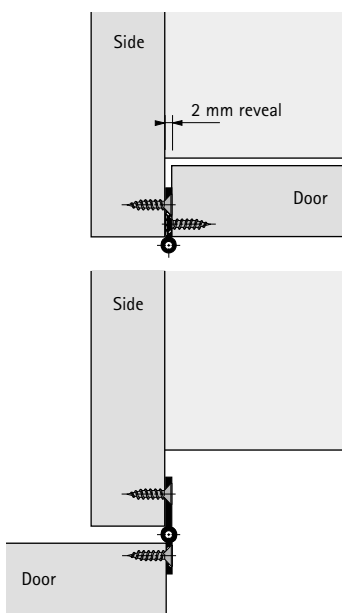

### Hinge length 50 mm

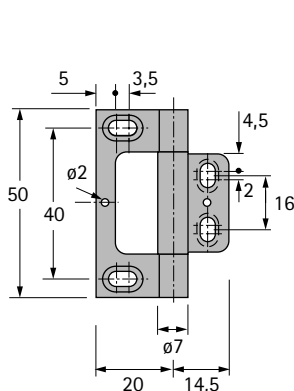

### Hinge length 75 mm

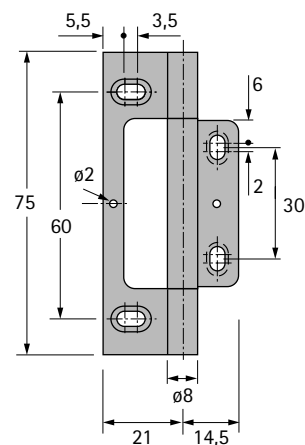

# Narrow hinges



## Narrow hinges

Steel version  
yellow zinc-plated  
with riveted pin.

3

| Article                        | Finish             | Size    | Order no. | PU     |
|--------------------------------|--------------------|---------|-----------|--------|
| Narrow hinges<br>steel version | yellow zinc-plated | 30 x 25 | 045 001   | 10 pcs |
|                                | yellow zinc-plated | 40 x 25 | 045 002   | 10 pcs |
|                                | yellow zinc-plated | 50 x 35 | 045 003   | 10 pcs |
|                                | yellow zinc-plated | 60 x 35 | 045 004   | 10 pcs |
|                                | yellow zinc-plated | 75 x 50 | 045 005   | 10 pcs |

| Size<br>a x b | d1<br>mm | d2<br>mm | Screw<br>holes | DIN 97<br>ø |
|---------------|----------|----------|----------------|-------------|
| 30 x 25       | 4,5      | 1,0      | 4              | 2,5         |
| 40 x 25       | 4,9      | 1,0      | 4              | 3,0         |
| 50 x 35       | 5,3      | 1,2      | 4              | 3,0         |
| 60 x 35       | 6,0      | 1,4      | 4              | 3,0         |
| 75 x 50       | 7,5      | 1,5      | 6              | 4,0         |

## Mounting example

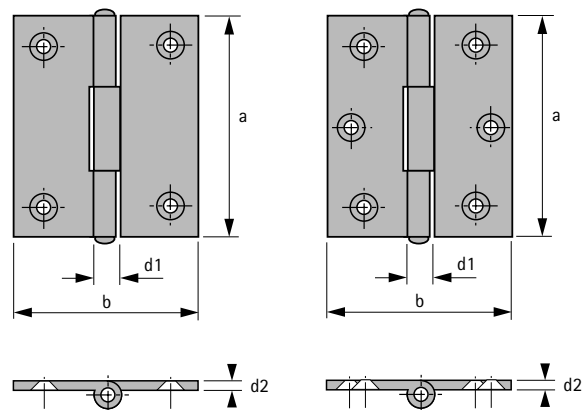
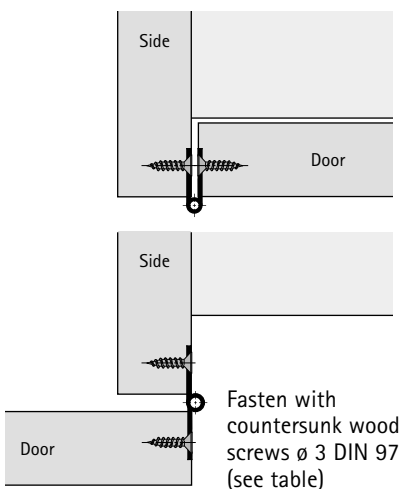

# Square hinges

3

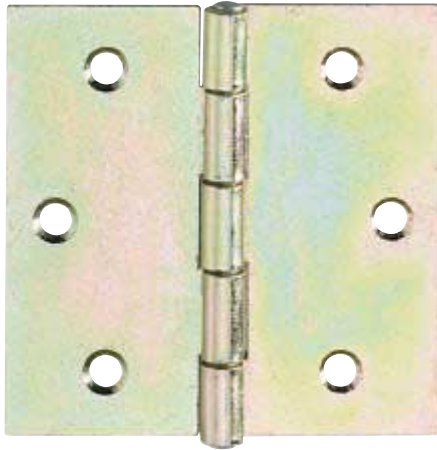

**Square hinges**  
Steel version  
yellow zinc-plated  
with riveted pin.

| Article                        | Finish             | Size    | Order no. | PU     |
|--------------------------------|--------------------|---------|-----------|--------|
| Square hinges<br>steel version | yellow zinc-plated | 30 x 30 | 045 006   | 10 pcs |
|                                | yellow zinc-plated | 40 x 40 | 045 007   | 10 pcs |
|                                | yellow zinc-plated | 50 x 50 | 045 008   | 10 pcs |
|                                | yellow zinc-plated | 60 x 60 | 045 009   | 10 pcs |
|                                | yellow zinc-plated | 80 x 80 | 045 011   | 10 pcs |

| Size<br>a x b | d1<br>mm | d2<br>mm | Screw<br>holes | DIN 97<br>ø |
|---------------|----------|----------|----------------|-------------|
| 30 x 30       | 4,5      | 1,0      | 4              | 6,0         |
| 40 x 40       | 4,5      | 1,0      | 6              | 6,0         |
| 50 x 50       | 5,5      | 1,0      | 6              | 6,0         |
| 60 x 60       | 6,0      | 1,5      | 6              | 8,0         |
| 80 x 80       | 6,4      | 1,5      | 6              | 8,0         |

## Mounting example

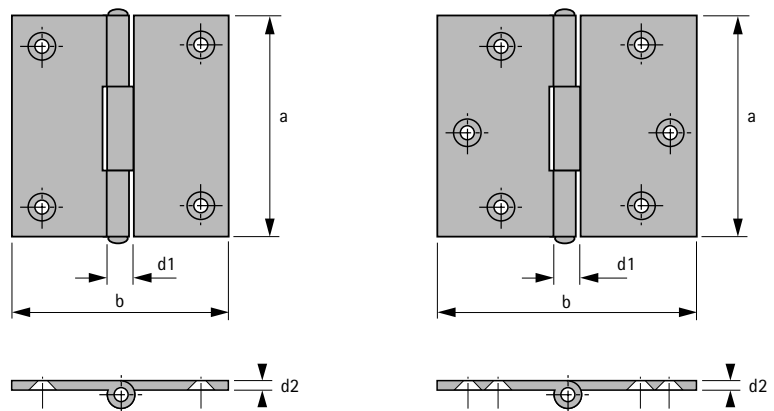
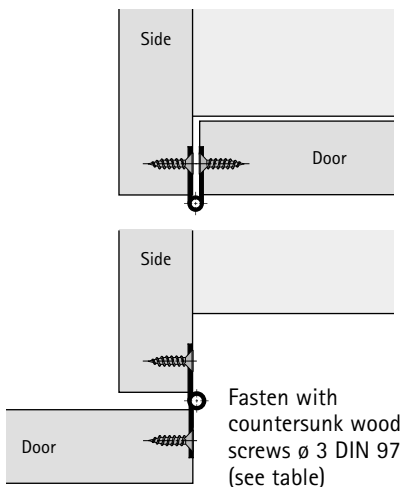

# Wide hinges

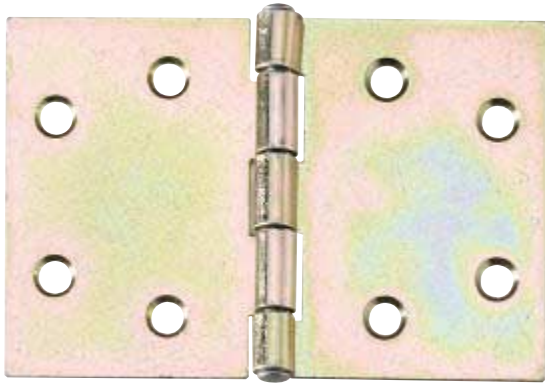

## Wide hinges

Steel version  
yellow zinc-plated  
with riveted pin.

3

| Article                      | Finish             | Size     | Order no. | PU     |
|------------------------------|--------------------|----------|-----------|--------|
| Wide hinges<br>steel version | yellow zinc-plated | 30 x 45  | 045 012   | 10 pcs |
|                              | yellow zinc-plated | 40 x 60  | 045 013   | 10 pcs |
|                              | yellow zinc-plated | 50 x 75  | 045 014   | 10 pcs |
|                              | yellow zinc-plated | 60 x 90  | 045 015   | 10 pcs |
|                              | yellow zinc-plated | 70 x 105 | 045 016   | 10 pcs |
|                              | yellow zinc-plated | 80 x 120 | 045 017   | 10 pcs |

| Size<br>a x b | d1<br>mm | d2<br>mm | Screw<br>holes | DIN 97<br>ø |
|---------------|----------|----------|----------------|-------------|
| 30 x 45       | 4,5      | 1,0      | 6              | 2,5         |
| 40 x 60       | 6,6      | 1,2      | 6              | 3,0         |
| 50 x 75       | 5,9      | 1,2      | 8              | 3,0         |
| 60 x 90       | 7,0      | 1,5      | 8              | 3,0         |
| 70 x 105      | 8,0      | 1,5      | 8              | 4,0         |
| 80 x 120      | 7,9      | 1,8      | 8              | 4,0         |

## Mounting example

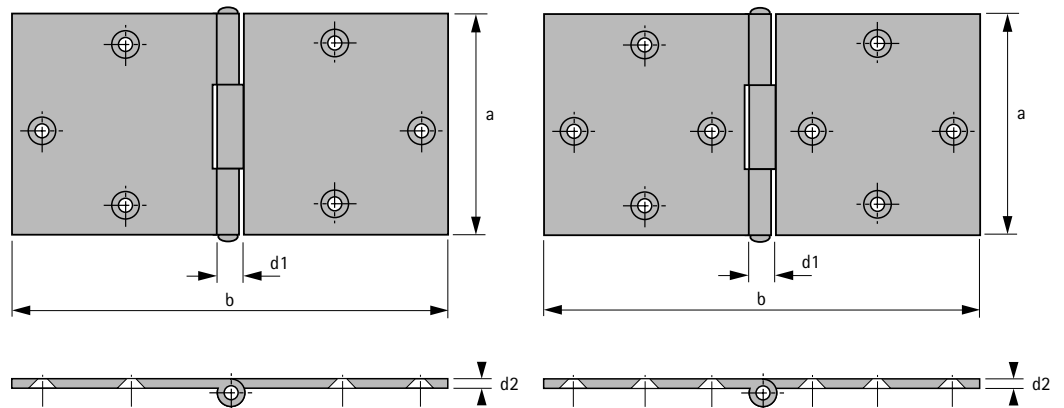
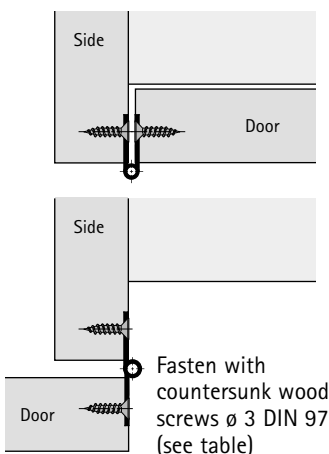

# Surface hinges

## Quality all the way.

Consistent quality,  
from the blank profile to the high-grade finish brass hinge.

High quality materials, experience and craftsmen's skills have ensured the success of the ONI quality brand for over 40 years.

3 ONI stands for know-how and ultra-precise manufacture and finishing of hinges made from pure solid brass.

Modern production techniques are only partly responsible for the high product quality; it also still depends to a great extent on the work done by hand by experienced specialist craftsmen. The unsurpassed gleaming surface of ONI hinges, for example, can only be achieved by hand-polishing.

The company is also very flexible when it comes to special versions or delivery service.

From individual items to medium or large production runs, standard versions to special shapes, Hettich always has a comprehensive, economical product line available.







## Left-handed and right-handed flaps according to DIN 107

**Left-hand hinge:** if a door opens towards you with the pivot point on the left, this is called a left-hand door (DIN left-hand) with a left-hand hinge.

**Right-hand hinge:**

if a door opens towards you with the pivot point on the right, this is called a right-hand door (DIN right) with a right-hand hinge.

Left-hand hinge

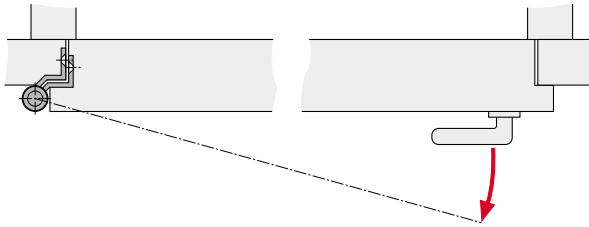

Right-hand hinge

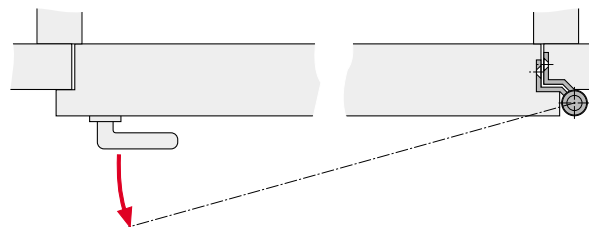

Lift-off hinges are basically either left-hand or right-hand.

## Mounting instructions

If a third hinge is required on heavy doors, this should not be fitted in the middle of the door but about 250 mm below the upper hinge.

This increases the stress tolerance.

Door buffers should be mounted as far from the pivot point of the hinge as possible. Otherwise, the lever action could destroy the hinges or even the door itself.

Recommended hinge position for wide and heavy doors.

When fitting hinges, the distance between the top two hinges should be increased accordingly to take account of the hinge length.

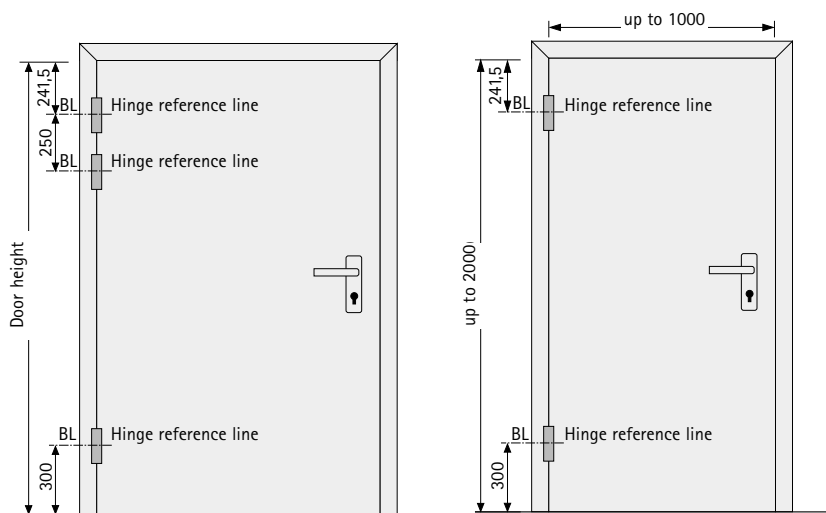

Hinge position on doors according to DIN 18101

## Hinge reference line

The hinge reference line is an imaginary line in relation to any hinge, regardless of design or handing.

It is used to determine the hinge position precisely in terms of height with respect to the door leaf and frame and helps ensure rational, precise mounting.

DIN 18101 specifies the hinge position and DIN 18268 establishes the hinge reference line for various types of hinge.

## Wartung

The bearings and pivot pin of door hardware are lightly oiled to protect them from corrosion.

After fitting a hinge, the bearings and pivot pin should be thoroughly cleaned and lubricated with an acid-free long-life grease (VOB) before use.

To ensure long service life and keep the hinge running freely and silently, it should be greased from time to time according to the degree of stress.

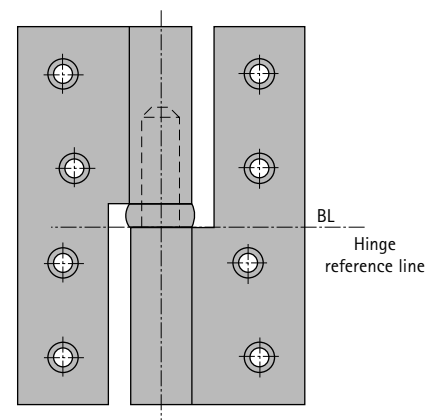

# The choice is yours.

All of the standard hinges shown in this catalogue may be modified in any way you wish.

## Narrower flaps

No matter whether the hinge is straight or cranked, the flap can be manufactured in any chosen width.

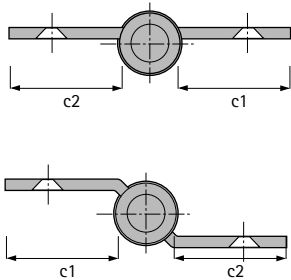

## Rounded corners

Needless to say, ONI also supplies all flaps with rounded corners.

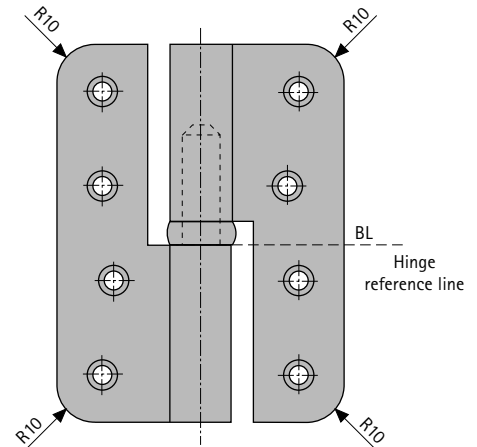

## Other drilling pattern

If the application so demands, the hole pattern can be adjusted to suit requirements.

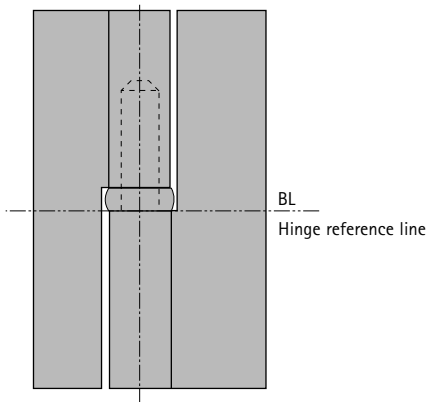

## With removable pin

All surface hinges are also available with removable pin.

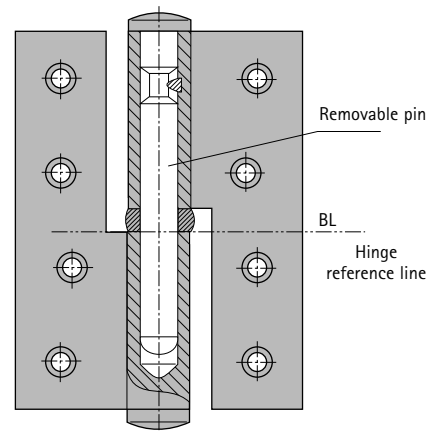

## Other finishes

In addition to the standard finishes, ONI also offers hinges with an untreated surface or in high-gloss nickel-plated, matt chrome-plated, high-gloss chrome-plated, antique bronze.

## Decorative finials

The right decorative finial for any application.



ZK 9



ZK 14



ZK 19



ZK 24

# Brass surface hinge 885 straight

## Specification

Hettich surface hinge 885, straight, from drawn brass profile material, drilled and milled, with ball bearing. Knuckle  $\varnothing$  16 mm, flap thickness 3,0 mm.

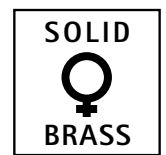

### Surface hinge for flush doors

#### Solid brass

Knuckle  $\varnothing$  16 mm, flap thickness 3,0 mm, drawn brass, drilled and milled, with steel pin, ball bearing and ZK 19 decorative finial or without decorative finial.



ZK 19

3

| Article  | Finish             | Hinge length 100 mm<br>Order no. | Hinge length 120 mm<br>Order no. | Hinge length 140 mm<br>Order no. | Hinge length 160 mm<br>Order no. | PU    |
|--|--------------------|----------------------------------|----------------------------------|----------------------------------|----------------------------------|-------|
| Surface hinge for flush doors without decorative finials <b>left</b> | polished brass     | 031 707                          | 031 709                          | 031 711                          | 031 713                          | 2 pcs |
| without decorative finials <b>right</b>                              | nickel-plated matt | 042 830                          | 042 832                          | 042 834                          | 042 836                          | 2 pcs |
|  | polished brass     | 031 708                          | 031 710                          | 031 712                          | 031 714                          | 2 pcs |
|  | nickel-plated matt | 042 831                          | 042 833                          | 042 835                          | 042 837                          | 2 pcs |
| with ZK 19 <b>left</b>   | polished brass     | 031 697                          | 031 699                          | 031 701                          | 031 703                          | 2 pcs |
| with ZK 19 <b>right</b>  | polished brass     | 031 698                          | 031 700                          | 031 702                          | 031 704                          | 2 pcs |

### Mounting example

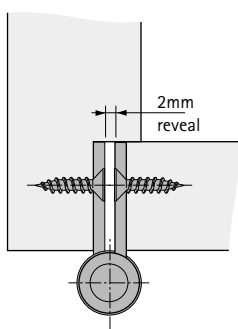

### Hinge length 100 mm

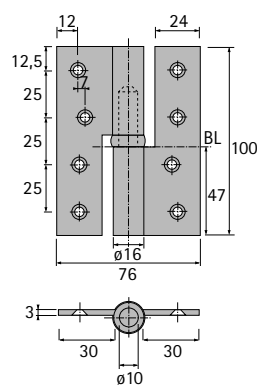

### Hinge length 120 mm

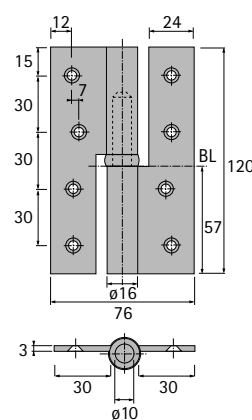

### Hinge length 140 mm

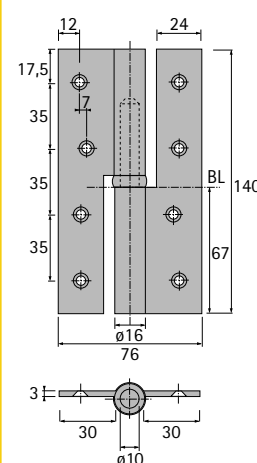

### Hinge length 160 mm

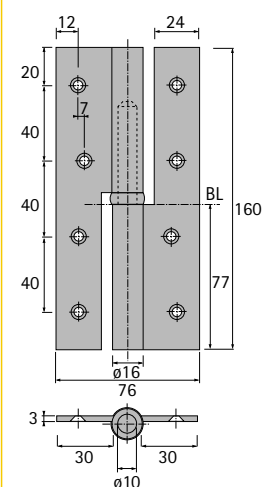

Fixing with countersunk wood screws  $\varnothing$  5 DIN 97

BL = Hinge reference line

# Brass surface hinge 888 Cranking D 13

## Specification

Hettich surface hinge 888, cranking D 13, in drawn brass profile material, drilled and milled, with ball bearing. Knuckle  $\varnothing$  16 mm, flap thickness 3,0 mm.

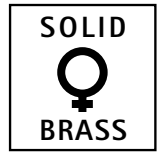

### Surface hinge for rebated doors Solid brass

Knuckle  $\varnothing$  16 mm, flap thickness 3,0 mm, drawn brass, drilled and milled, with steel pin, ball bearing and ZK 19 decorative finials or without decorative finial.



ZK 19



| Article   | Finish             | Hinge length 100 mm<br>Order no. | Hinge length 120 mm<br>Order no. | Hinge length 140 mm<br>Order no. | Hinge length 160 mm<br>Order no. | PU    |
|---|--------------------|----------------------------------|----------------------------------|----------------------------------|----------------------------------|-------|
| Surface hinge for flush doors<br>without decorative finials <b>left</b> | polished brass     | 031 737                          | 031 739                          | 031 741                          | 031 743                          | 2 pcs |
| without decorative finials <b>right</b>                                 | nickel-plated matt | 042 840                          | 042 842                          | 042 844                          | 042 846                          | 2 pcs |
| with ZK 19 <b>left</b>  | polished brass     | 031 738                          | 031 740                          | 031 742                          | 031 744                          | 2 pcs |
| with ZK 19 <b>right</b>   | nickel-plated matt | 042 841                          | 042 843                          | 042 845                          | 042 847                          | 2 pcs |
|   | polished brass     | 031 747                          | 031 749                          | 031 751                          | 031 753                          | 2 pcs |
|   | polished brass     | 031 748                          | 031 750                          | 031 752                          | 031 754                          | 2 pcs |

### Mounting example

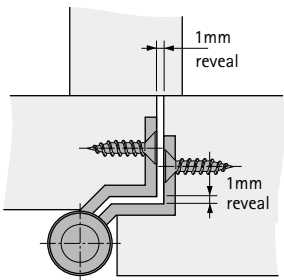

Fixing with countersunk wood screws  $\varnothing$  5 DIN 97

### Hinge length 100 mm

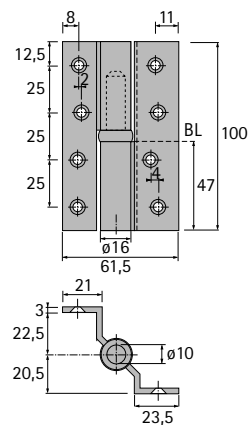

### Hinge length 120 mm

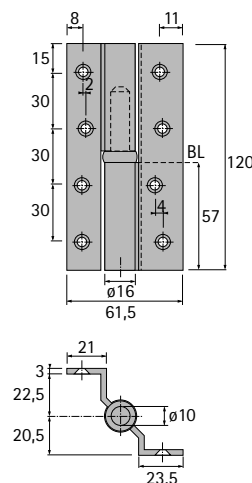

### Hinge length 140 mm

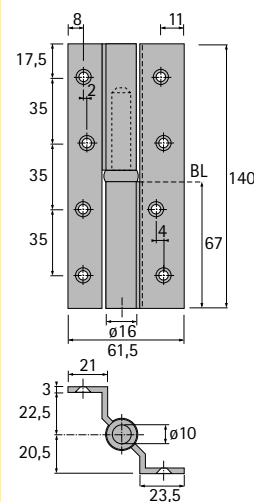

### Hinge length 160 mm

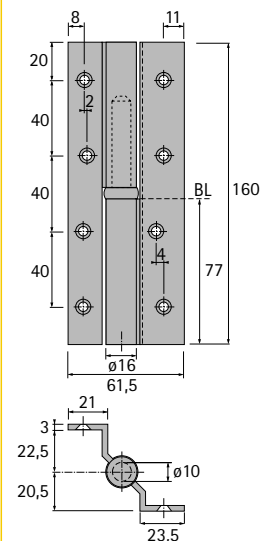

BL = Hinge reference line

# Material

## Fitting components manufactured from brass profiles

| Article           | Material number | Material abbreviation | Tensile strength $\sigma_B$<br>N/mm <sup>2</sup> | Density<br>kg/dm <sup>3</sup> | Resistance  |
|-------------------|-----------------|-----------------------|--|-------------------------------|---|
| Hinges            | 2.0410.08       | Cu Zn 44 Pb 2 p       | ~ 590  | 8,40                          | Resistant to neutral saline solutions, fresh water, sea water, acidic pit water, organic acids, pure water vapour and to most organic solvents. |
| Commercial hinges | 2.0402.20       | Cu Zn 40 Pb 2 zh      | ~ 400  | 8,43                          |   |

Remark: The information given above has been taken from the pertinent literature of the material manufacturers.  
We are unable to assume any liability for the correctness of this information.

## Surface protection

- Enamelled to prevent oxidation.  
ONI hinges in polished brass, matt brushed brass and coloured brass are enamelled.
- The colourless hard glaze provides lasting surface protection.
- Fingermarks, moisture stains etc. of the type often left behind during assembly can no longer occur.
- The fittings retain their true appearance even after prolonged storage.
- Electroplated items do not require this surface protection.

# Fax order to your specialist retailer

In addition to the surface hinges featured in this documentation, we also provide you with the option of creating your own specific surface hinge within the bounds of the criteria set out below. Please combine your chosen surface finish with hinge length, decorative finial etc., making your entries in the order panel

## Example

| Surface hinge no. | Finish                   | Hinge length | Decorative finials | Pin                | Corners | Hole          | Lacquer     |
|-------------------|--------------------------|--------------|--------------------|--------------------|---------|---------------|-------------|
| 885 right         | polished brass           | 100          | without            | fixed              | angular | predrilled    | lacquered   |
| 885 left          | matt brushed brass       | 120          | ZK19               | with removable pin | rounded | without holes | unlacquered |
| 888 right         | matt chrome-plated       | 180          | ZK19               |                    |         |               |             |
| 888 left          | high-gloss chrome-plated |              |                    |                    |         |               |             |

3

| Pos. no. | Surface hinge | Finish | Hinge length mm | Decorative finials | Pin | Corners | Hole | Lacquer | Order quantity |
|----------|---------------|--------|-----------------|--------------------|-----|---------|------|---------|----------------|
| 1        |               |        |                 |                    |     |         |      |         |                |
| 2        |               |        |                 |                    |     |         |      |         |                |
| 3        |               |        |                 |                    |     |         |      |         |                |
| 4        |               |        |                 |                    |     |         |      |         |                |
| 5        |               |        |                 |                    |     |         |      |         |                |
| 6        |               |        |                 |                    |     |         |      |         |                |
| 7        |               |        |                 |                    |     |         |      |         |                |
| 8        |               |        |                 |                    |     |         |      |         |                |

Joiner/interior fitter:

Date: \_\_\_\_\_ Signature: \_\_\_\_\_

# Piano hinges



## Piano hinge – 20 mm open width

Knuckle length 15 mm  
Hole spacing 60 mm  
Length 3500 mm

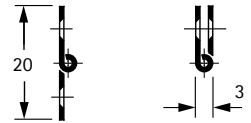

| Article                         | Finish                             | Order no. | PU     |
|---------------------------------|------------------------------------|-----------|--------|
| Piano hinge<br>20 mm open width | BILAC® brass-plated laquered steel | 040 671   | 50 pcs |
|                                 | nickel-plated steel                | 040 672   | 50 pcs |
|                                 | stainless steel                    | 040 674   | 10 pcs |
|                                 | brass                              | 061 755   | 10 pcs |



## Piano hinge – 25 mm open width

Knuckle length 15 mm  
Hole spacing 60 mm  
Length 3500 mm

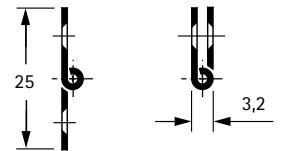

| Article                         | Finish                             | Order no. | PU     |
|---------------------------------|------------------------------------|-----------|--------|
| Piano hinge<br>25 mm open width | BILAC® brass-plated laquered steel | 040 677   | 50 pcs |
|                                 | nickel-plated steel                | 040 678   | 50 pcs |
|                                 | stainless steel                    | 040 680   | 10 pcs |
|                                 | brass                              | 059 727   | 10 pcs |

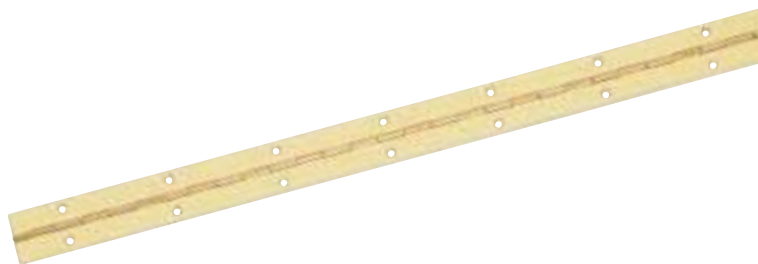

## Piano hinge – 28 mm open width

Knuckle length 15 mm  
Hole spacing 60 mm  
Length 3500 mm

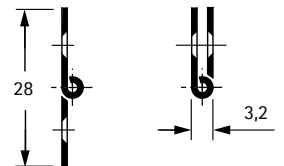

| Article                         | Finish                             | Order no. | PU     |
|---------------------------------|------------------------------------|-----------|--------|
| Piano hinge<br>28 mm open width | BILAC® brass-plated laquered steel | 040 683   | 50 pcs |

# Piano hinges



**Piano hinge – 32 mm open with**  
 Knuckle length 15 mm  
 Hole spacing 60 mm  
 Length 3500 mm

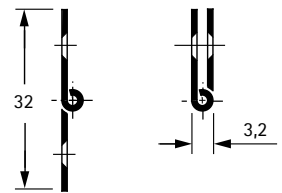

3

| Article                         | Finish                             | Order no. | PU     |
|---------------------------------|------------------------------------|-----------|--------|
| Piano hinge<br>32 mm open width | BILAC® brass-plated laquered steel | 040 689   | 50 pcs |
|                                 | nickel-plated steel                | 040 690   | 50 pcs |
|                                 | burnished steel                    | 040 691   | 50 pcs |
|                                 | stainless steel                    | 040 692   | 10 pcs |
|                                 | brass                              | 058 123   | 10 pcs |

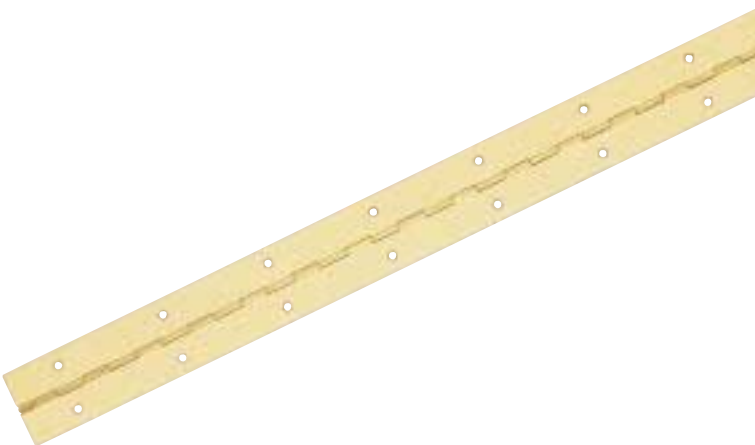

**Piano hinge – 40 mm open width**  
 Knuckle length 15 mm  
 Hole spacing 60 mm  
 Length 3500 mm

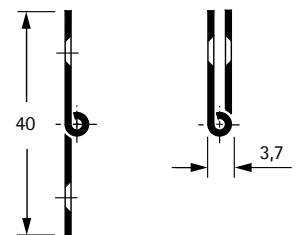

| Article                         | Finish                             | Order no. | PU     |
|---------------------------------|------------------------------------|-----------|--------|
| Piano hinge<br>40 mm open width | BILAC® brass-plated laquered steel | 040 695   | 50 pcs |
|                                 | nickel-plated steel                | 040 696   | 50 pcs |
|                                 | stainless steel                    | 040 698   | 10 pcs |
|                                 | brass                              | 059 046   | 10 pcs |

# Pivot hinge

3



## Pivot hinge for inset doors

For door thicknesses 16 - 20 mm

Opening angle 140°

Straightforward assembly and door adjustment



| Article              | Finish        | Order no. | PU     |
|----------------------|---------------|-----------|--------|
| Pivot hinge complete | nickel-plated | 069933    | 10 pcs |

## Mounting examples

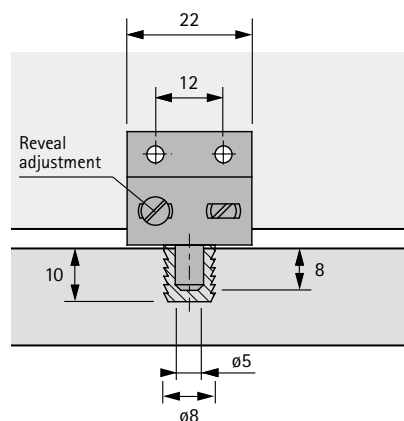
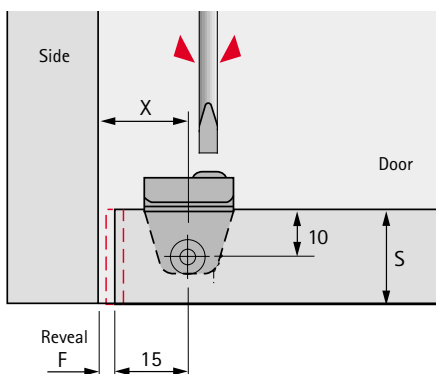

| Door thickness S | Reveal F | Distance X |
|------------------|----------|------------|
| 16 mm            | 1,2 mm   | 16,2 mm    |
| 17 mm            | 1,5 mm   | 16,5 mm    |
| 18 mm            | 2,0 mm   | 17,0 mm    |
| 19 mm            | 2,5 mm   | 17,5 mm    |
| 20 mm            | 3,0 mm   | 18,0 mm    |

# Pivot hinge



## Pivot hinge for small inset doors

For door thicknesses 12 - 21 mm

Opening angle 140°

Straightforward assembly and door adjustment.

The doors are easily inserted and removed by simply withdrawing the spring-mounted pin.



| Article              | Finish | Order no. | PU      |
|----------------------|--------|-----------|---------|
| Pivot hinge complete | white  | 006 731   | 200 pcs |
|                      | brown  | 006 732   | 200 pcs |

3

## Mounting example

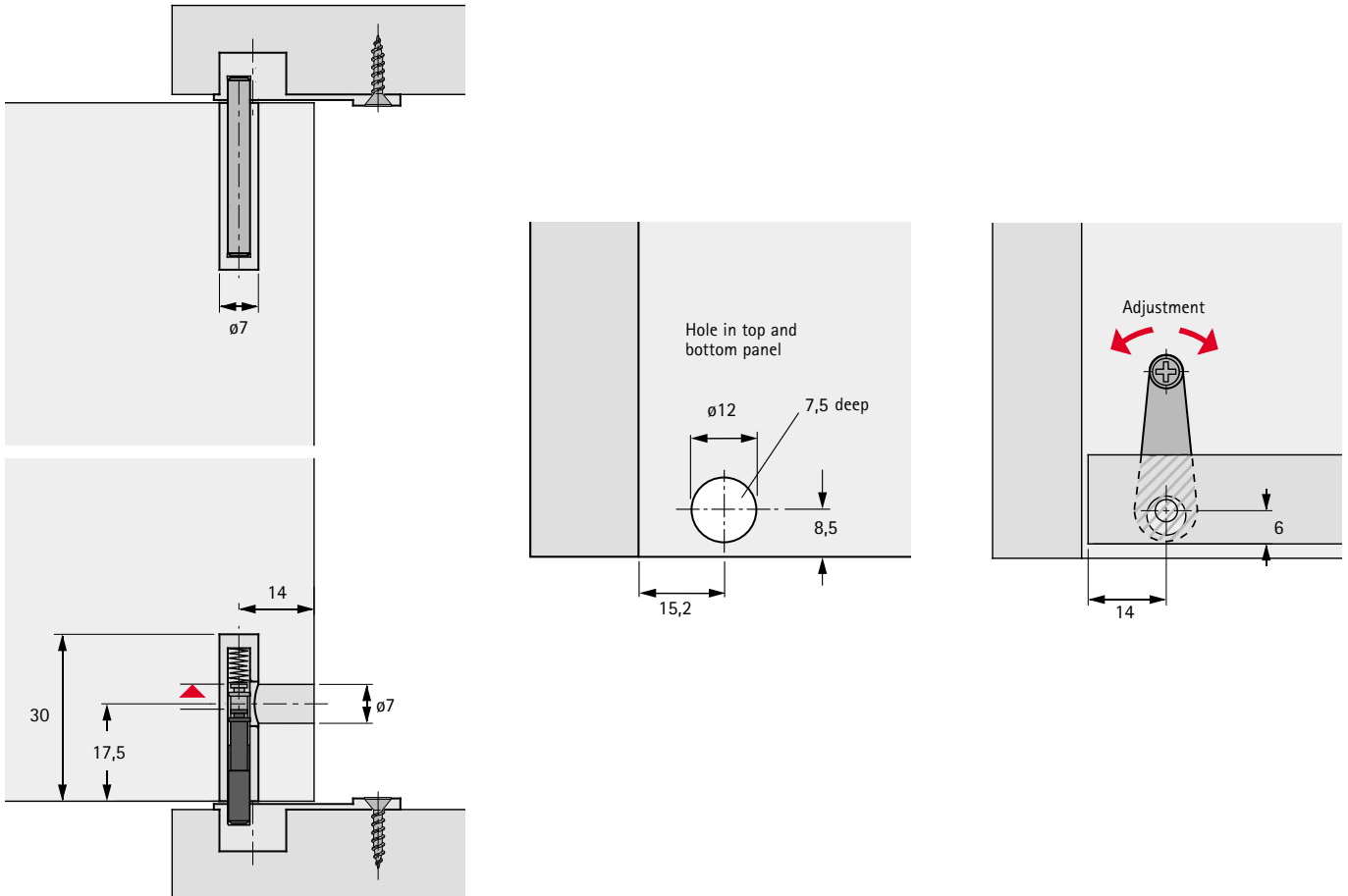

# Pivot hinge Double swing door fitting

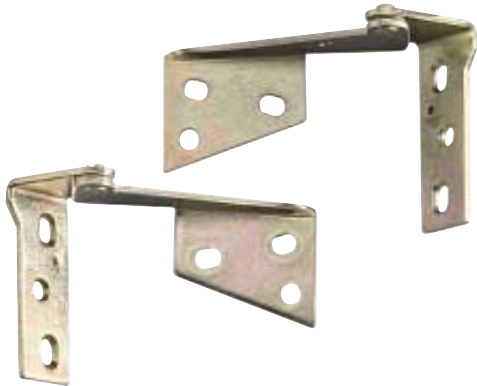

## Pivot hinge for overlay louvre doors

For side thickness of at least 16 mm and door thickness of 28 mm  
Opening angle 180°  
Steel, zinc-plated  
PU = 2 hinges for 1 door  
with 12 fixing screws

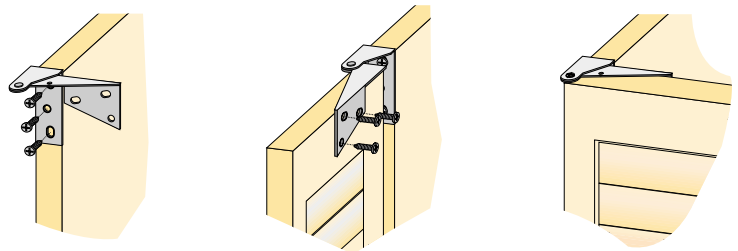
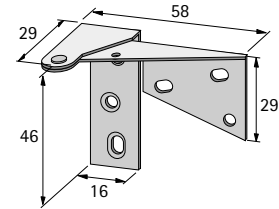

| Article                      | Finish      | Order no. | PU |
|------------------------------|-------------|-----------|----|
| Pivot hinge for louvre doors | zinc-plated | 001 439   | 1  |



## Double swing door fitting

For door thicknesses 19 - 30 mm  
Brass-plated steel  
PU = 2 hinges  
with 12 fixing screws  
Door weight max. 4 kg

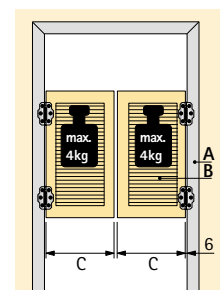
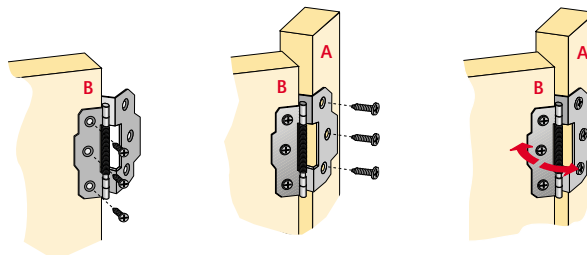
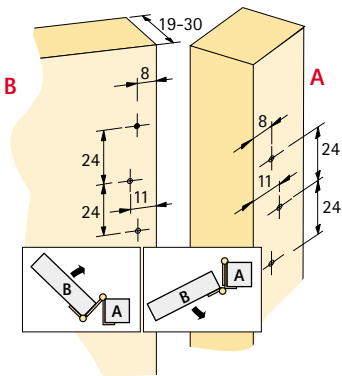
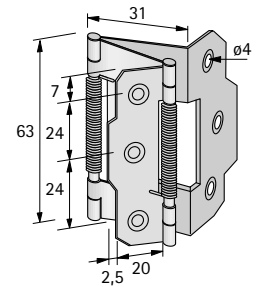

| Article                   | Finish       | Order no. | PU |
|---------------------------|--------------|-----------|----|
| Double swing door fitting | brass plated | 001 512   | 1  |

# Double swing door fitting



## Double swing door fitting for louvre doors

For door thicknesses 19 - 44 mm

Door can be held open by a catch

Brass-plated steel

PU = 4 fittings for 2 doors  
with 16 fixing screws

| Article                                    | Finish       | Order no. | PU |
|--|--------------|-----------|----|
| Double swing door fitting for louvre doors | brass plated | 000 858   | 1  |

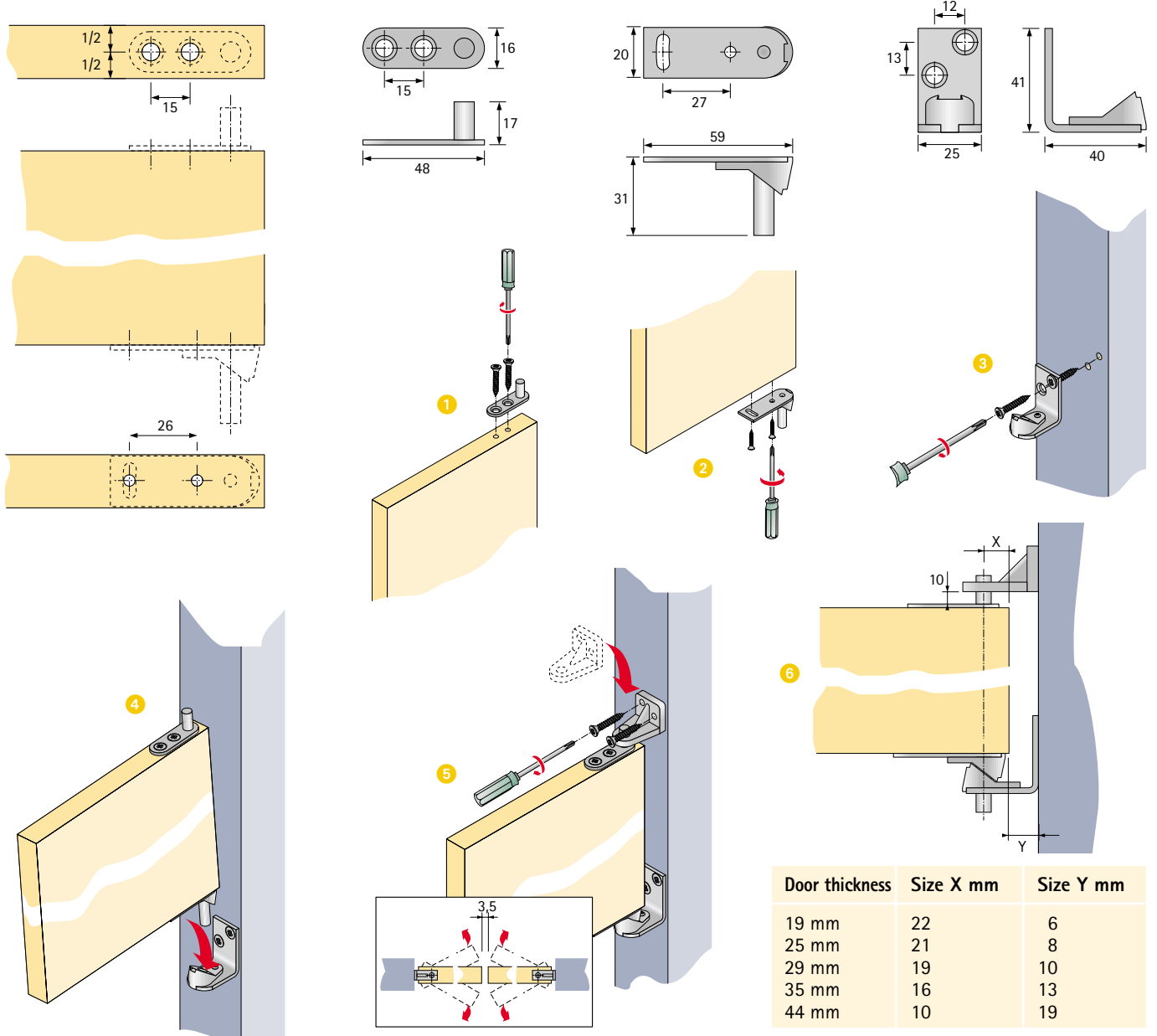

# Flap hinge Markant 7.1



## Flap hinge 7.1 for overlay flaps

Separate installation of mounting plate and flap arm

Cup hole 35 mm

Depth adjustment + 2mm / -2 mm  
Height adjustment + 2mm / -2 mm  
via mounting plate,  
see page 3.148

Nickel-plated steel



| Article                | Finish        | Order no. | PU      |
|------------------------|---------------|-----------|---------|
| Flap hinge Markant 7.1 | nickel-plated | 046 849   | 25 sets |

3

## Mounting example

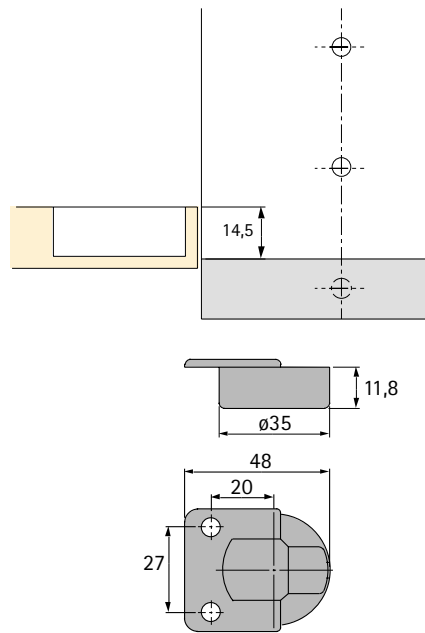
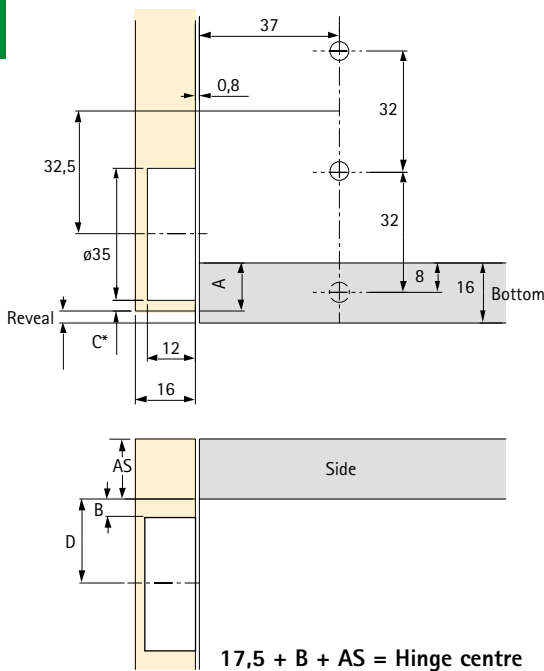

| Cup distance C mm | A mm |
|-------------------|------|
| 3                 | 13   |
| 4                 | 14   |
| 4,5               | 14,5 |
| 5                 | 15   |
| 6                 | 16   |
| 7                 | 17   |

| Mounting plate Distance mm | B mm | D mm |
|----------------------------|------|------|
| 0                          | 6,0  | 23,5 |
| 1,5                        | 7,5  | 25,0 |
| 3,0                        | 9,0  | 26,5 |
| 5,0                        | 11,0 | 28,5 |

Minimum door reveal allowed for each door (door mounting) to determine cup and mounting plate distance:

| Cup distance C* mm | Door thickness mm |     |     |     |     |     |     |     |     |     |      |      |
|--------------------|-------------------|-----|-----|-----|-----|-----|-----|-----|-----|-----|------|------|
|                    | 16                | 18  | 20  | 22  | 24  | 26  | 28  | 30  | 32  | 34  | 36   | 38   |
| 3                  | 0,4               | 0,8 | 1,2 | 1,8 | 2,4 | 3,2 | 4,3 | 5,9 | 7,7 | 9,6 | 11,5 | 13,3 |
| 4                  | 0,4               | 0,8 | 1,2 | 1,8 | 2,4 | 3,2 | 4,2 | 5,6 | 7,2 | 9,1 | 10,9 | 12,7 |
| 4,5                | 0,4               | 0,8 | 1,2 | 1,8 | 2,4 | 3,2 | 4,2 | 5,6 | 7,2 | 9,1 | 10,9 | 12,7 |
| 5                  | 0,4               | 0,7 | 1,1 | 1,6 | 2,3 | 3,1 | 4,0 | 5,2 | 6,7 | 8,5 | 10,2 | 12,0 |
| 6                  | 0,4               | 0,7 | 1,1 | 1,6 | 2,3 | 3,0 | 3,8 | 4,9 | 6,2 | 7,9 | 9,5  | 11,3 |
| 7                  | 0,4               | 0,6 | 1,0 | 1,5 | 2,1 | 2,9 | 3,6 | 4,6 | 5,7 | 7,3 | 8,8  | 10,6 |

# Flap hinge Markant 6



## Flap hinge Markant 6, Precision die-cast zinc

Hinge parts are mounted separately in bottom panel and flap, enabling subsequent flap assembly. Flaps are aligned through independent height, side and depth adjustment.

Identical hole dimensions in bottom panel and flap. Three screw fasteners ensure firm and exact hinge seating in bottom panel and flap.

Hole edge break-out is hidden by covering lip. In open position, inside face edges of bottom panel and flap are flush before height adjustment.



| Article                 | Finish        | Order no. | PU     |
|-------------------------|---------------|-----------|--------|
| Flap hinge<br>Markant 6 | nickel-plated | 031 182   | 20 pcs |
|                         | bronze        | 031 183   | 20 pcs |
|                         | brass plated  | 042 579   | 20 pcs |

3

## Mounting example

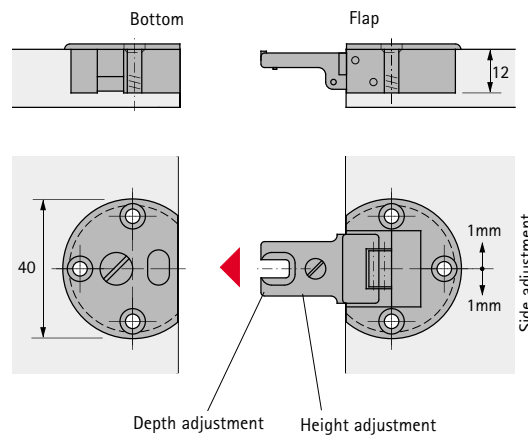
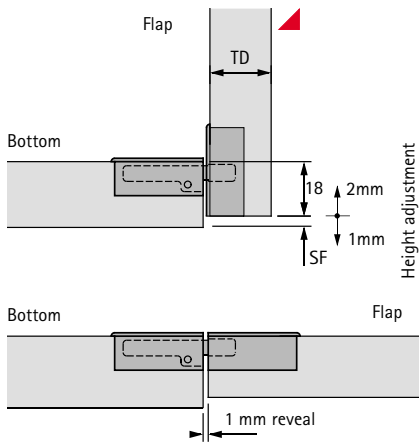

## Hole pattern

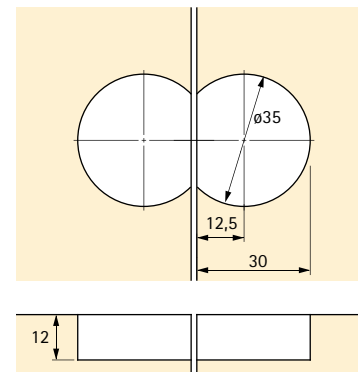

## Reveal dimensions

| Flap thickness TD | Min. reveal SF |
|-------------------|----------------|
| 16 mm             | 1,0 mm         |
| 17 mm             | 1,0 mm         |
| 18 mm             | 1,5 mm         |
| 19 mm             | 2,5 mm         |
| 20 mm             | 3,5 mm         |

Fasten with  $\varnothing 3,5 \times 15$  mm or  $3,5 \times 13$  mm countersunk wood screws, head  $\varnothing 6$  mm

# Flap hinge Markant 10



## Flap hinge plastic Markant 10, Precision die-cast zinc

Only 3 mm recess in bottom panel.

In open position, inside face of bottom panel and flap are flush.

With a 16-mm gauge door and 16-mm gauge panel, the flap is flush with panel when closed.

Please observe minimum visible reveal SF, see below

No interfering shoulders, recesses or steps



| Article                  | Finish              | Order no. | PU     |
|--------------------------|---------------------|-----------|--------|
| Flap hinge<br>Markant 10 | nickel-plated white | 046 696   | 20 pcs |
|                          | chrome plated       | 046 697   | 20 pcs |
|                          | bronze              | 046 698   | 20 pcs |
|                          | brass plated        | 046 699   | 20 pcs |

### Mounting example

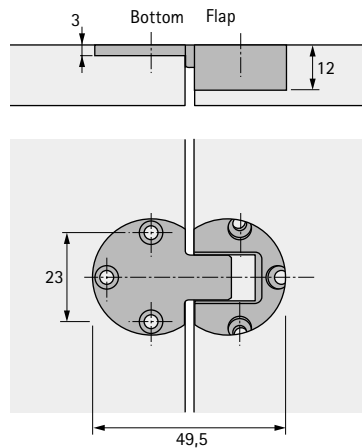
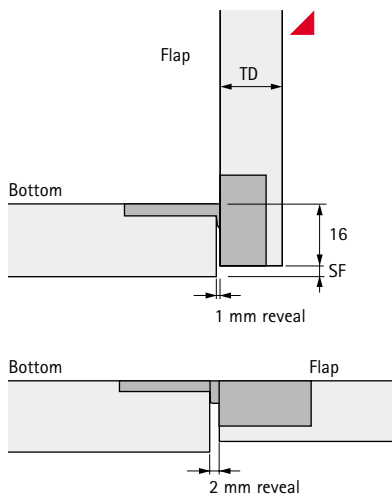

### Hole dimension

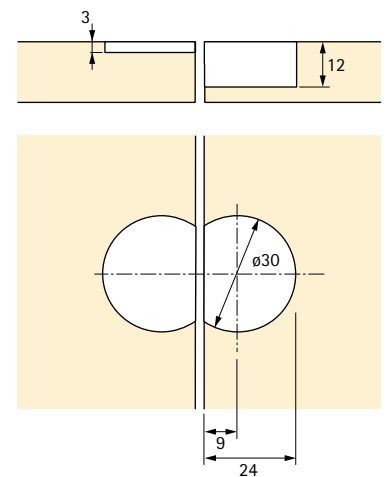

### Reveal dimensions

| Flap thickness TD | Min. reveal SF |
|-------------------|----------------|
| 16 mm             | 2,0 mm         |
| 17 mm             | 3,0 mm         |
| 18 mm             | 4,0 mm         |
| 19 mm             | 5,0 mm         |
| 20 mm             | 6,0 mm         |

Fasten with countersunk wood screws  
ø 3 x 15 mm

# Flap hinge Markant 4



## Flap hinge Markant 4, Plastic

Only 5 mm recess in bottom panel.  
In open position, inside face of  
bottom panel and flap are flush.  
No interfering shoulders,  
recesses or steps



| Article                 | Finish | Order no. | PU     |
|-------------------------|--------|-----------|--------|
| Flap hinge<br>Markant 4 | white  | 072 897   | 20 pcs |
|                         | brown  | 072 898   | 20 pcs |
|                         | black  | 072 899   | 20 pcs |

3

### Mounting example

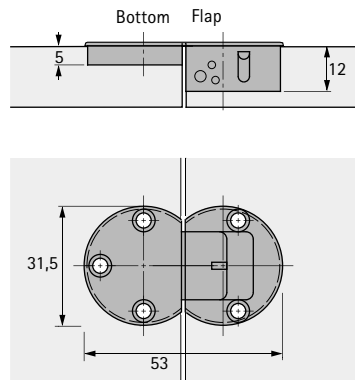
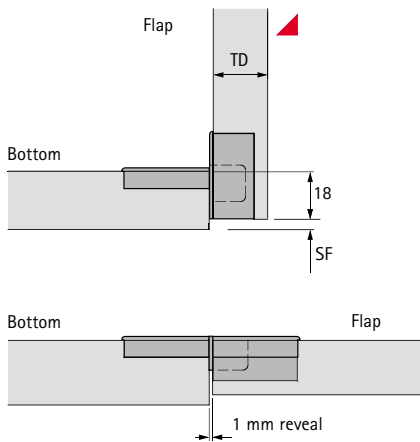

### Hole dimension

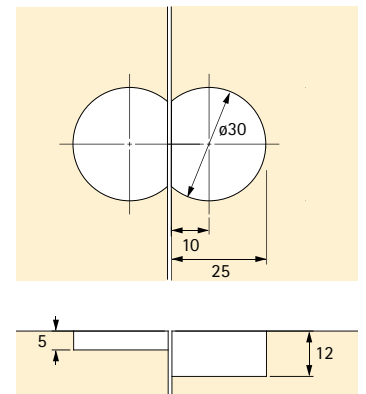

### Reveal dimensions

| Flap thickness TD | Min. reveal SF |
|-------------------|----------------|
| 16 mm             | 2,0 mm         |
| 17 mm             | 3,0 mm         |
| 18 mm             | 4,0 mm         |
| 19 mm             | 5,0 mm         |
| 20 mm             | 6,0 mm         |

Fasten with countersunk wood screws  
ø 3 x 15 mm

# Flap hinge Markant 9

3



## Flap hinge Markant 9

Plastic housing,  
screw-on zinc die-cast mounting plate.

Closing angle 105°

Flap is aligned by height,  
side and depth adjustment.

In open position, before height adjustment,  
inside face of bottom panel and flap are flush.



| Article                 | Finish              | Order no. | PU     |
|-------------------------|---------------------|-----------|--------|
| Flap hinge<br>Markant 9 | white/nickel-plated | 072 900   | 20 pcs |
|                         | brown/nickel-plated | 072 901   | 20 pcs |
|                         | black/nickel-plated | 072 902   | 20 pcs |

### Mounting example

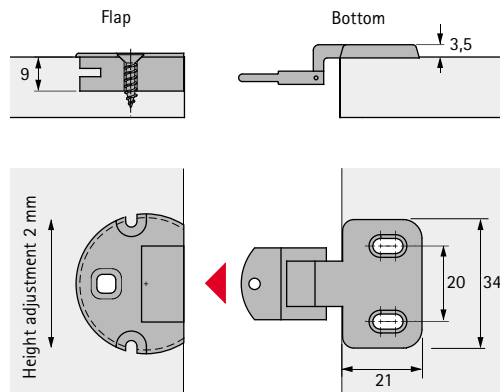
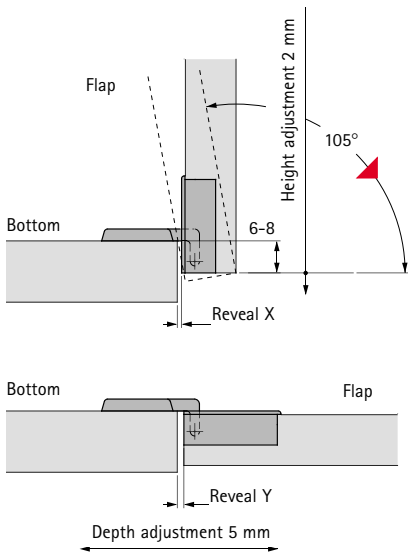

### Hole dimension

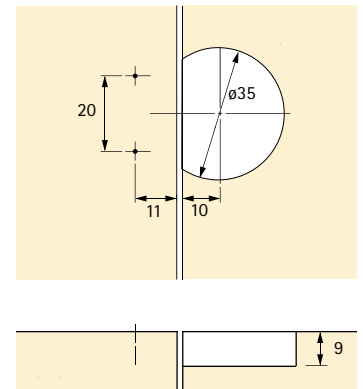

| Flap overlay | Reveal X | Reveal Y |
|--------------|----------|----------|
| 6 mm         | 0,5 mm   | 2,5 mm   |
| 7 mm         | 1,0 mm   | 2,0 mm   |
| 8 mm         | 1,5 mm   | 1,6 mm   |

Fasten with countersunk wood screws  
ø 3,5 x 16 mm

# Flap hinges 135 and 137

## Solid brass

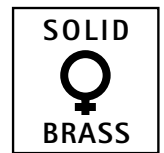

### Flap hinges 135 and 137

#### Solid brass

Drawn brass, drilled and milled,  
with fixed brass pin.  
With semi-circular flaps  
for machine recessing.

Flap hinge 135  
**with countersunk holes on the outside**

Flap hinge 137  
**with countersunk holes on the inside**

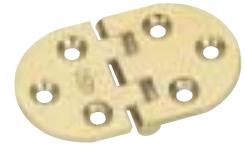

| Article        | Finish                   | Order no. | PU     |
|----------------|--------------------------|-----------|--------|
| Flap hinge 135 | polished brass           | 042 581   | 20 pcs |
|                | high-gloss nickel-plated | 042 585   | 20 pcs |
| Flap hinge 137 | polished brass           | 042 582   | 20 pcs |
|                | high-gloss nickel-plated | 042 586   | 20 pcs |



### Mounting example

### Flap hinge 135

### Flap hinge 137

#### Flap hinge 135

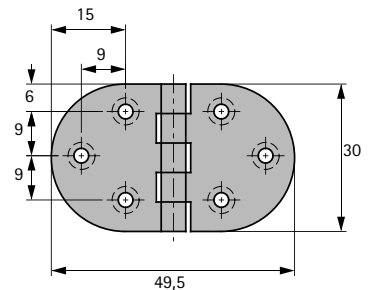
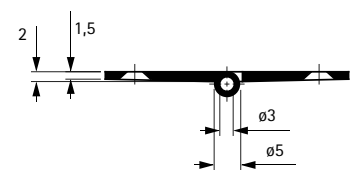
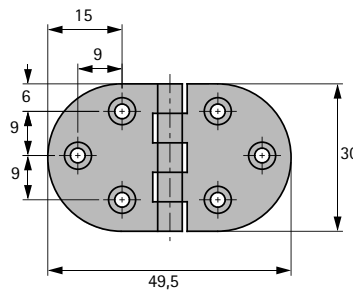
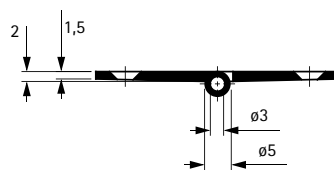
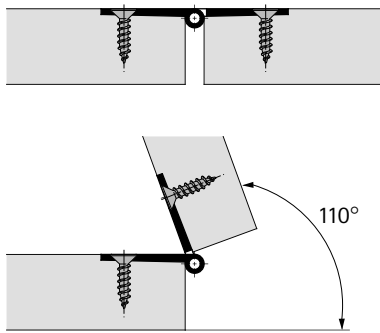

#### Flap hinge 137

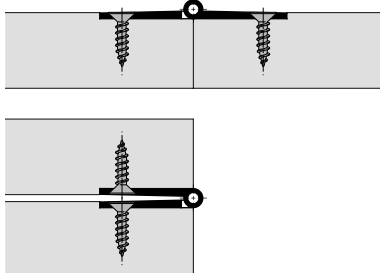

Fasten with countersunk wood screws  
ø 3 DIN 97

# Flap hinges 140 and 142

## Solid brass

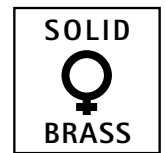

### Flap hinges 140 and 142

#### Solid brass

Drawn brass, drilled and milled,  
with fixed stainless steel pin.  
With semi-circular flaps  
for machine recessing.

Flap hinge 140  
**with countersunk holes on the outside**  
Flap hinge 142  
**with countersunk holes on the inside**



| Article        | Finish                   | Order no. | PU     |
|----------------|--------------------------|-----------|--------|
| Flap hinge 140 | polished brass           | 042 583   | 20 pcs |
|                | high-gloss nickel-plated | 042 587   | 20 pcs |
| Flap hinge 142 | polished brass           | 042 584   | 20 pcs |
|                | high-gloss nickel-plated | 042 588   | 20 pcs |

### Mounting example

### Flap hinge 140

### Flap hinge 142

#### Flap hinge 140

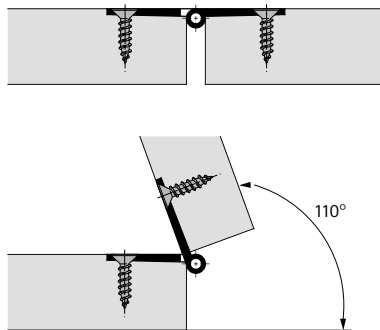

#### Flap hinge 142

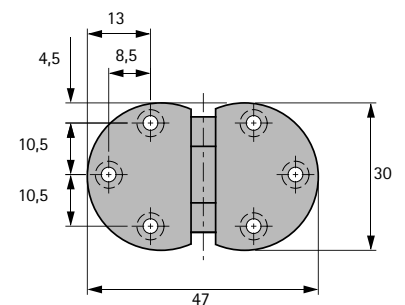
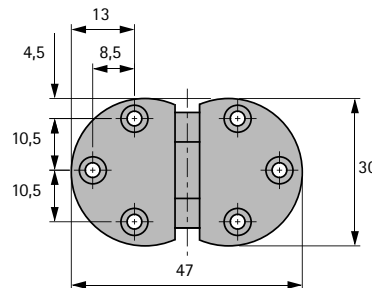
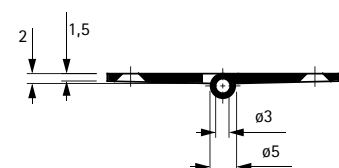
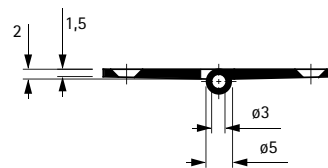
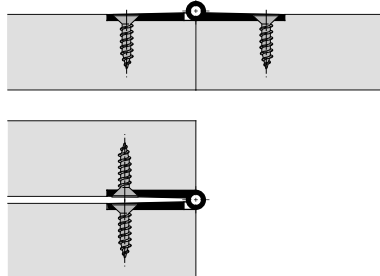

Fasten with countersunk wood screws  
ø 3,5 DIN 97

# Table hinge 130

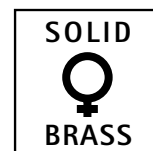

## Table hinge 130 Solid brass

Drawn brass, drilled and milled, with 2 fixed steel pins and a double joint. With semi-circular flaps for machine recessing.

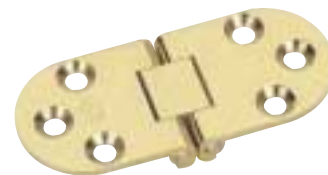

| Article         | Finish              | Order no. | PU     |
|-----------------|---------------------|-----------|--------|
| Table hinge 130 | polished brass      | 031 101   | 20 pcs |
|                 | nickel-plated brass | 042 589   | 20 pcs |

3

## Mounting example

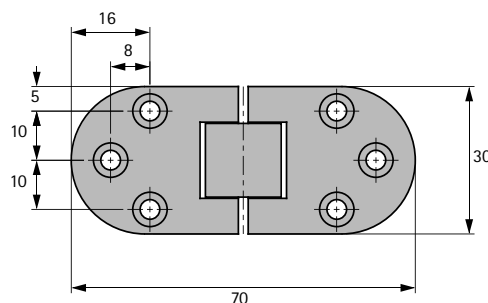
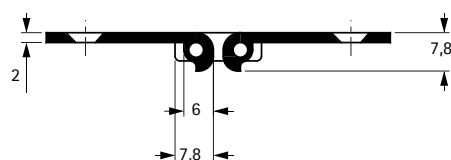
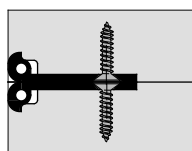

Fasten with countersunk wood screws  
ø 4 DIN 97

# Special-purpose hinge 121 in steel for corner cabinets

3



Special-purpose hinge  
for (kitchen) corner cabinets  
Steel  
Rolled steel,  
with steel pin.  
Usable left and right.



| Article                   | Finish        | Order no. | PU     |
|---------------------------|---------------|-----------|--------|
| Special-purpose hinge 121 | nickel-plated | 071 821   | 10 pcs |

## Mounting example

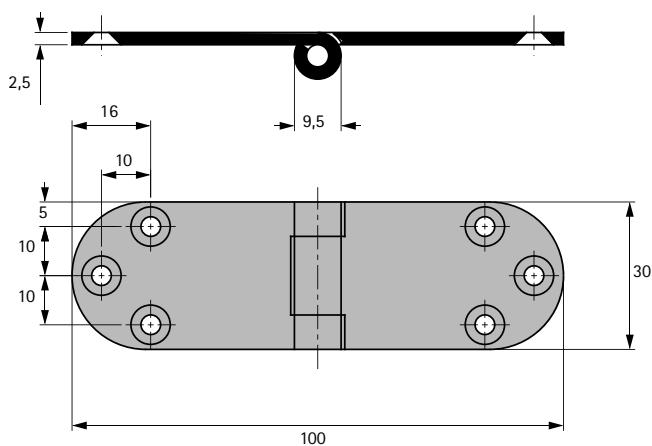
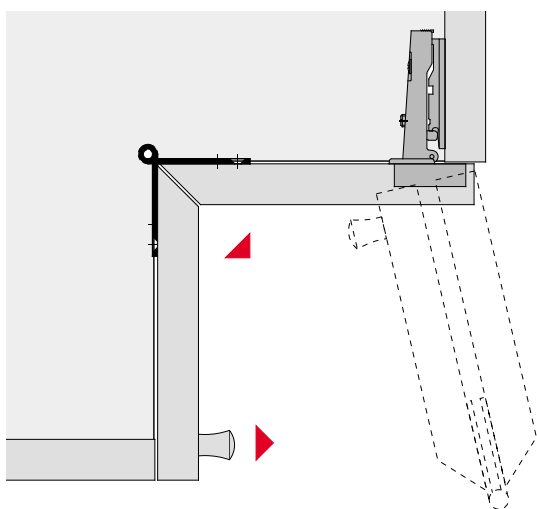

Fasten with countersunk wood screws  
ø 3,5 DIN 97

# Special hinge 121 in brass for corner cabinets

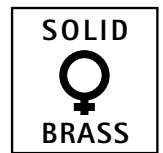

## Special-purpose hinge for corner cabinets Solid brass

Drawn brass, drilled and milled,  
with fixed brass pin.  
Extremely durable and sturdy.  
Usable left and right.



| Article                   | Finish                   | Order no. | PU     |
|---------------------------|--------------------------|-----------|--------|
| Special-purpose hinge 121 | high-gloss nickel-plated | 068 574   | 10 pcs |

3

## Mounting example

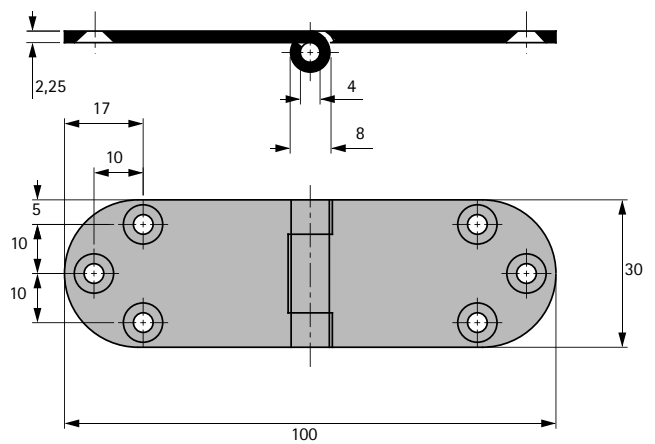
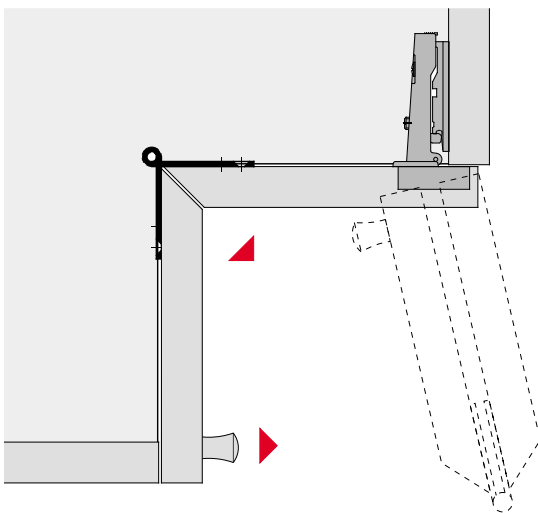

Fasten with countersunk wood screws  
ø 3,5 DIN 97

# Table hinge 120

3



## Table hinge 120 Solid brass

Drawn brass, drilled and milled,  
with fixed brass pin.

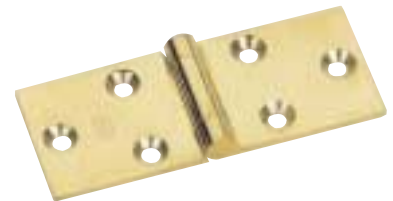

| Article         | Finish                   | Size<br>25 x 60 mm | Size<br>30 x 75 mm | Size<br>35 x 100 mm | PU     |
|-----------------|--------------------------|--------------------|--------------------|---------------------|--------|
| Table hinge 120 | smooth-polished brass    | 042 330            | 042 333            | 042 336             | 10 pcs |
|                 | polished brass           | 042 331            | 042 334            | 031 098             | 10 pcs |
|                 | high-gloss nickel-plated | 042 332            | 042 335            | 031 099             | 10 pcs |

### Mounting example

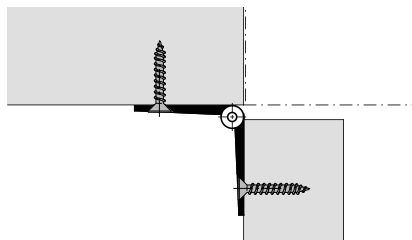

#### Size 25 x 60 mm

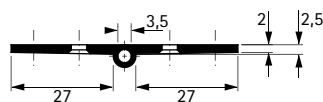
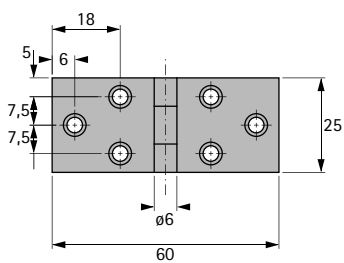

Fasten with  
countersunk wood screws  $\varnothing$  3 DIN 97

#### Size 30 x 75 mm

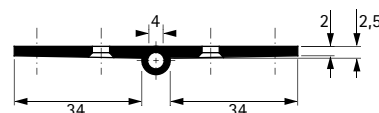
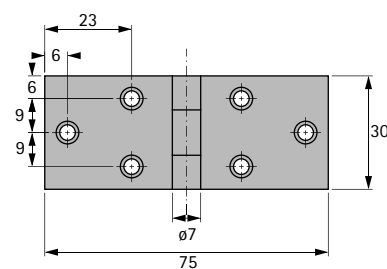

Fasten with  
countersunk wood screws  $\varnothing$  3,5 DIN 97

#### Size 35 x 100 mm

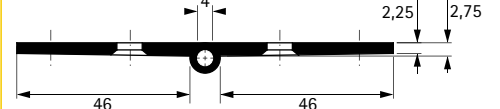
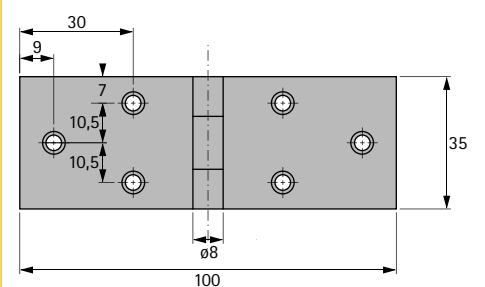

Fasten with  
countersunk wood screws  $\varnothing$  4 DIN 97

# Table hinge

## Table hinge Steel

yellow zinc-plated  
with riveted pin.

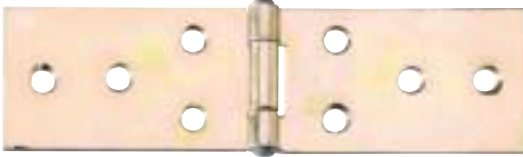

| Size<br>a x b | d1<br>mm | d2<br>mm | Screw<br>holes | DIN 97<br>ø |
|---------------|----------|----------|----------------|-------------|
| 24 x 60       | 5,2      | 1,0      | 6              | 3,0         |
| 28 x 80       | 6,0      | 1,2      | 6              | 3,0         |
| 32 x 100      | 6,6      | 1,2      | 6              | 3,0         |
| 33 x 120      | 7,0      | 1,4      | 8              | 3,0         |
| 34 x 140      | 7,7      | 1,5      | 8              | 3,5         |

| Article              | Finish             | Size     | Order no. | PU     |
|----------------------|--------------------|----------|-----------|--------|
| Table hinge<br>Steel | yellow zinc-plated | 24 x 60  | 045 018   | 10 pcs |
|                      | yellow zinc-plated | 28 x 80  | 045 019   | 10 pcs |
|                      | yellow zinc-plated | 32 x 100 | 045 021   | 10 pcs |
|                      | yellow zinc-plated | 33 x 120 | 045 022   | 10 pcs |
|                      | yellow zinc-plated | 34 x 140 | 045 023   | 10 pcs |

### Mounting example

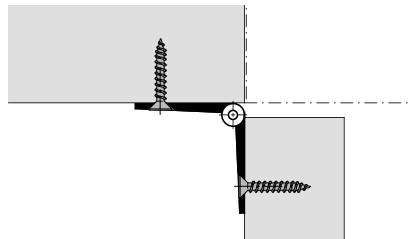

Fasten with  
countersunk wood  
screws ø 3 DIN 97  
(see table)

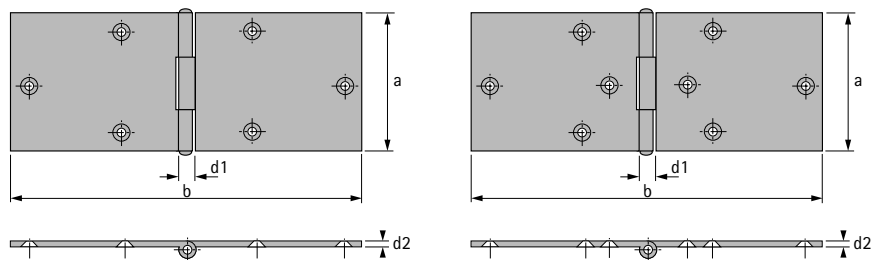

# Mirror hinge NOVI

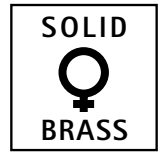

## Mirror hinge for 2- or 3-panel mirrors Solid brass

Drawn brass, drilled and milled, with fixed stainless steel pin, invisible from the outside, fittings leave no break in the mirror surface. Minimal space between 2 mirrors.

Holding feature at approx. 90° opening angle, usable left and right

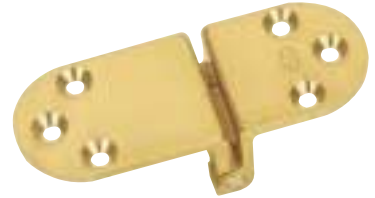

| Article           | Finish        | Order no. | PU |
|-------------------|---------------|-----------|----|
| Mirror hinge NOVI | matt enameled | 042 329   | 10 |

### Mounting example

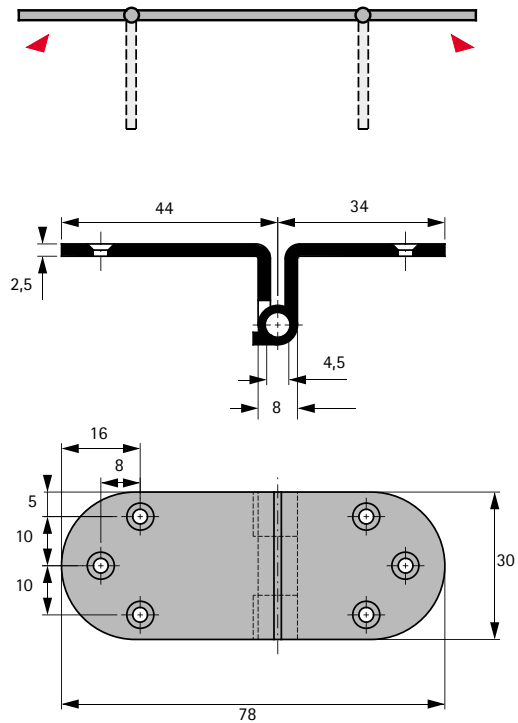
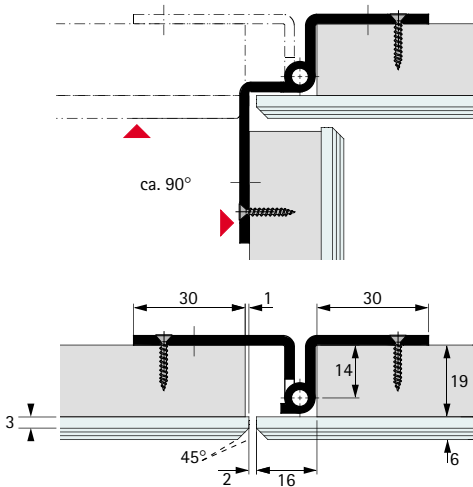

Fasten with countersunk wood screws  
ø 3,5 DIN 97

# Klassik D Flap stay with L 258 D support



## Klassik D Flap stay with L 258 D support All metal

High-quality, maintenance-free  
braking system with fine adjustment.

Guide bar, tie bar and base: nickel-plated steel  
Housing and support: nickel-plated die-cast zinc

Order numbers refer to left-hand versions.  
Use left or right by repositioning the base.

| Article       | Cabinet<br>internal height mm | Order no. | PU     |
|---------------|-------------------------------|-----------|--------|
| Klassik D/300 | 300 - 350                     | 016 173   | 10 pcs |
| Klassik D/350 | 350 - 400                     | 016 174   | 10 pcs |
| Klassik D/400 | 400 - 450                     | 016 175   | 10 pcs |
| Klassik D/450 | 450 - 500                     | 016 176   | 10 pcs |
| Klassik D/500 | 500 - 550                     | 016 177   | 10 pcs |
| Klassik D/550 | 550 - 600                     | 016 178   | 10 pcs |

### Assembly notes

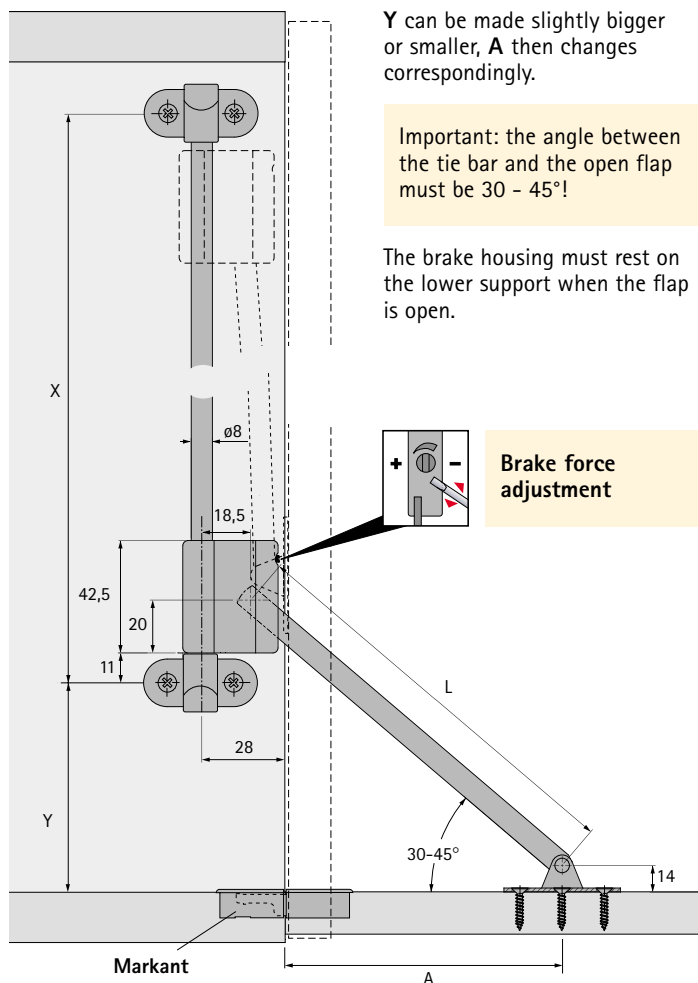

### L 258 D support

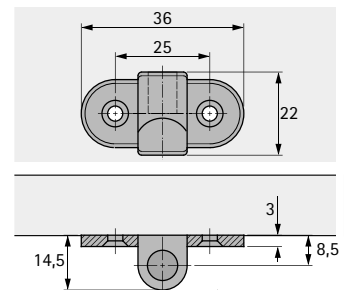

### A 3 base

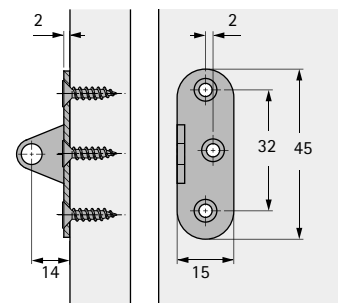

Fasten with  $\varnothing$  3,5 DIN95 / DIN97 wood screws

| Article       | Cabinet<br>internal height mm | Dimensions mm |     |     |     |
|---------------|-------------------------------|---------------|-----|-----|-----|
|               |                               | X             | Y   | A   | L   |
| Klassik D/300 | 300 - 350                     | 182           | 100 | 88  | 153 |
| Klassik D/350 | 350 - 400                     | 224           | 112 | 119 | 183 |
| Klassik D/400 | 400 - 450                     | 252           | 126 | 134 | 203 |
| Klassik D/450 | 450 - 500                     | 272           | 138 | 150 | 223 |
| Klassik D/500 | 500 - 550                     | 322           | 175 | 184 | 273 |
| Klassik D/550 | 550 - 600                     | 372           | 168 | 204 | 283 |

# Klassik D Flap stay with LS 3280 D support



## Klassik D Flap stay with LS 3280 D support All metal

High-quality, maintenance-free  
braking system with fine adjustment.

Guide bar, tie bar and base: nickel-plated steel  
Housing and support: nickel-plated die-cast zinc

Order numbers refer to left-hand versions.  
Use left or right by repositioning the base.

| Article       | Cabinet<br>internal height mm | Order no. | PU     |
|---------------|-------------------------------|-----------|--------|
| Klassik D/275 | 290 - 340                     | 020 864   | 10 pcs |
| Klassik D/340 | 360 - 400                     | 020 865   | 10 pcs |
| Klassik D/405 | 405 - 465                     | 020 866   | 10 pcs |
| Klassik D/465 | 465 - 560                     | 020 867   | 10 pcs |
| Klassik D/565 | 565 - 625                     | 020 868   | 10 pcs |

### Assembly notes

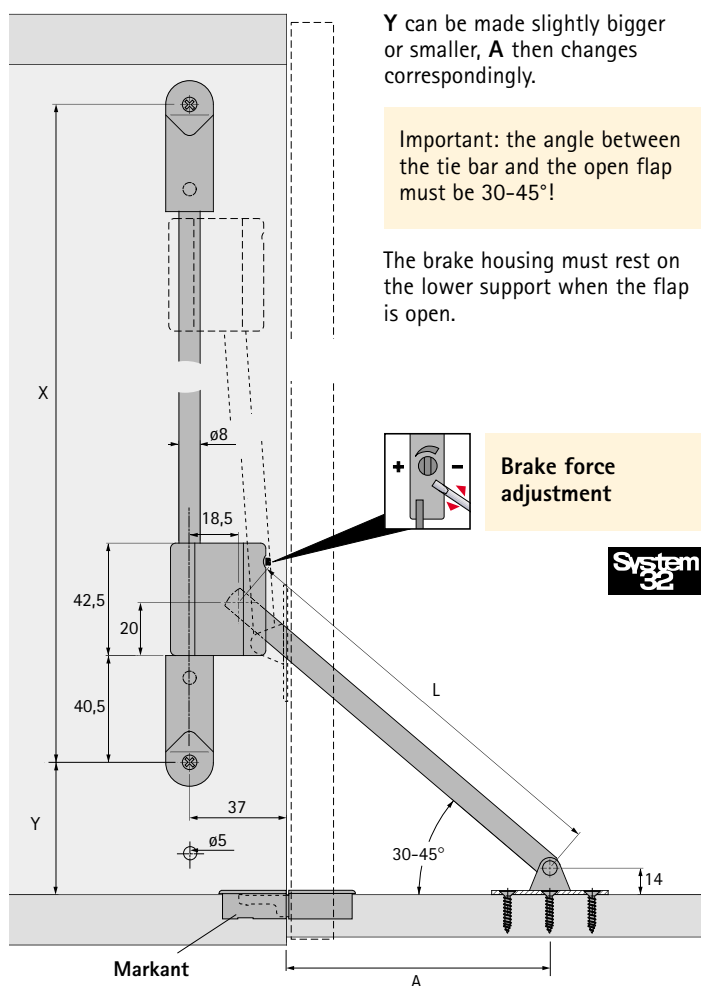

### LS 3280 D support

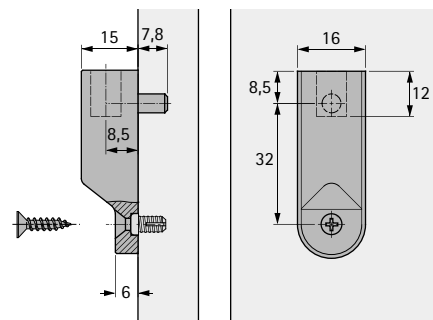

### A 3 base

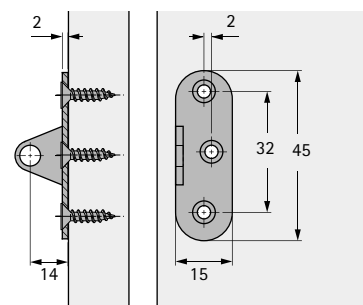

Fasten with wood screws  $\varnothing 3,5$  DIN 95 / DIN 97  
and  $\varnothing 5$  mm expanding dowels

| Article       | Cabinet<br>internal height mm | Dimensions mm |     |     |     |
|---------------|-------------------------------|---------------|-----|-----|-----|
|               |                               | X             | Y   | A   | L   |
| Klassik D/275 | 290 - 340                     | 252           | 24  | 70  | 113 |
| Klassik D/340 | 360 - 400                     | 288           | 56  | 95  | 153 |
| Klassik D/405 | 405 - 465                     | 320           | 56  | 133 | 183 |
| Klassik D/465 | 465 - 560                     | 352           | 88  | 159 | 223 |
| Klassik D/565 | 565 - 625                     | 416           | 120 | 198 | 273 |

# Klassik D Flap stay with magnetic catch



## Klassik D Flap stay with magnetic catch All metal

High-quality, maintenance free  
braking system with fine adjustment.  
Adjustable 4 mm magnetic catch.

Guide bar, tie bar and base: nickel-plated steel

Housing and support: nickel-plated die-cast zinc

| Article       | Cabinet<br>internal height | Order no.<br>right | Order no.<br>left | PU     |
|---------------|----------------------------|--------------------|-------------------|--------|
| Klassik D/275 | 290 - 340                  | 021 698            | 021 575           | 10 pcs |
| Klassik D/340 | 360 - 400                  | 021 699            | 021 577           | 10 pcs |
| Klassik D/405 | 405 - 465                  | 021 700            | 021 579           | 10 pcs |
| Klassik D/465 | 465 - 560                  | 021 701            | 021 581           | 10 pcs |
| Klassik D/565 | 565 - 625                  | 021 702            | 021 583           | 10 pcs |

## Assembly notes

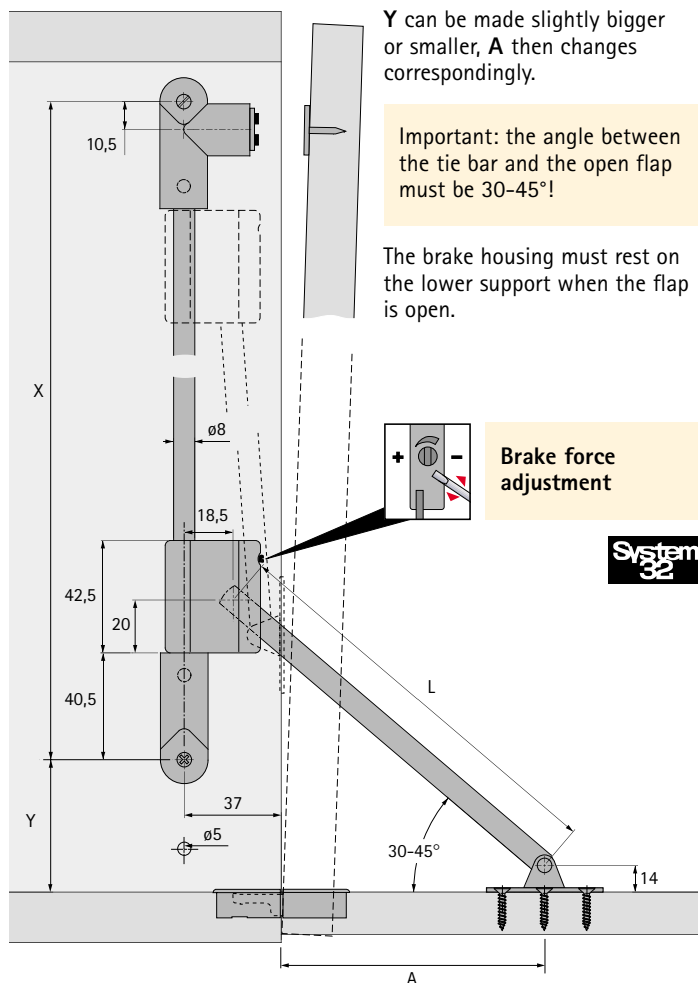

## MA 37 D magnetic support

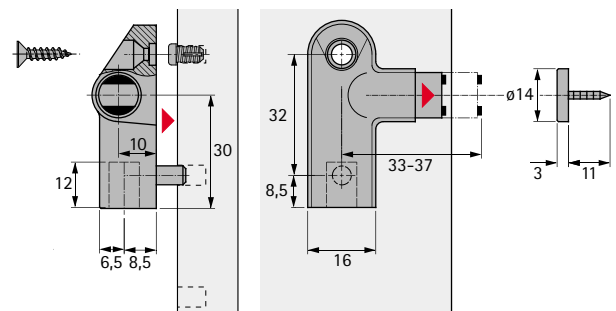

## A 3 base

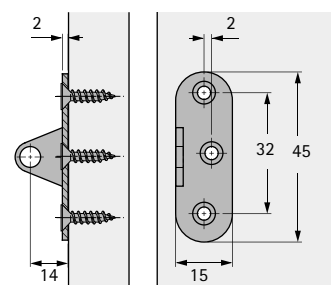

Fasten with wood screws  $\varnothing 3,5$  DIN 95 / DIN 97  
and  $\varnothing 5$  mm expanding dowels

| Article       | Cabinet<br>internal height mm | Dimensions mm |     |     |     |
|---------------|-------------------------------|---------------|-----|-----|-----|
|               |                               | X             | Y   | A   | L   |
| Klassik D/275 | 290 - 340                     | 252           | 24  | 70  | 113 |
| Klassik D/340 | 360 - 400                     | 288           | 56  | 95  | 153 |
| Klassik D/405 | 405 - 465                     | 320           | 56  | 133 | 183 |
| Klassik D/465 | 465 - 560                     | 352           | 88  | 159 | 223 |
| Klassik D/565 | 565 - 625                     | 416           | 120 | 198 | 273 |

# Flap stays

**Centra S 250 flap stay**  
with screw-on support and base  
Tie bar and base: nickel-plated steel  
Support: white or brown plastic



**KH flap stay**  
with screw-on support and base  
Nickel-plated steel



| Article      | Finish        | Order no. | PU     |
|--------------|---------------|-----------|--------|
| Centra S 250 | white support | 013 223   | 10 pcs |
| Centra S 250 | brown support | 013 224   | 10 pcs |

Mounting example

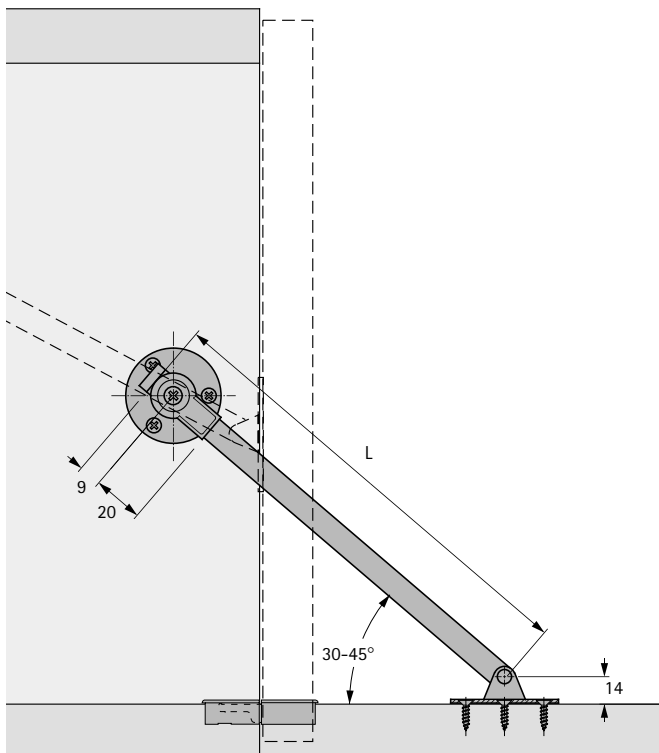

| Article | Length | Order no. | PU     |
|---------|--------|-----------|--------|
| KH 200  | 200 mm | 013 233   | 10 pcs |
| KH 250  | 250 mm | 013 235   | 10 pcs |

Mounting example

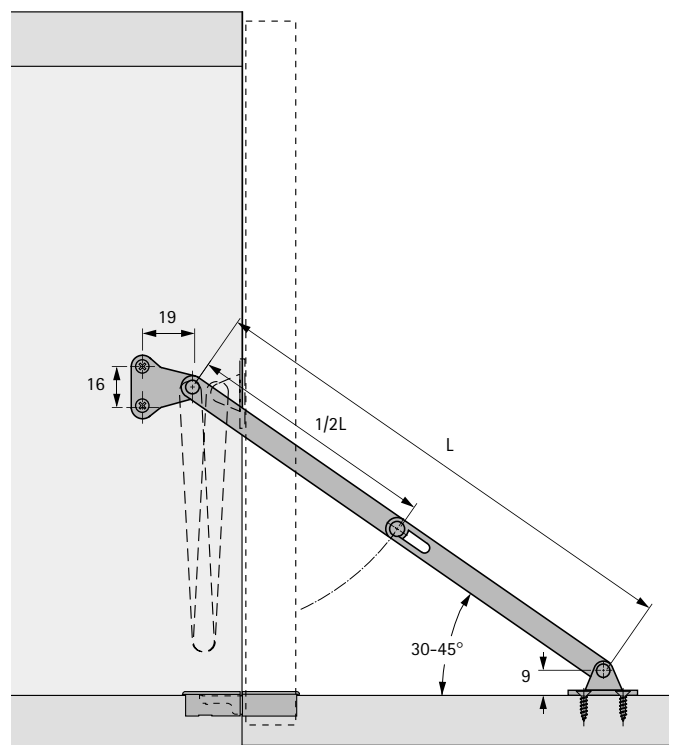

# Top box stays

## Top box stay

with screw-on support and base

The flap is held open by a catch.

Lifting the flap slightly releases the catch.

Support bar, support and base: nickel-plated steel



| Article      | Size L | Order no. | PU     |
|--------------|--------|-----------|--------|
| Top box stay | 167 mm | 072 996   | 10 pcs |
|              | 252 mm | 072 997   | 10 pcs |

## Mounting example

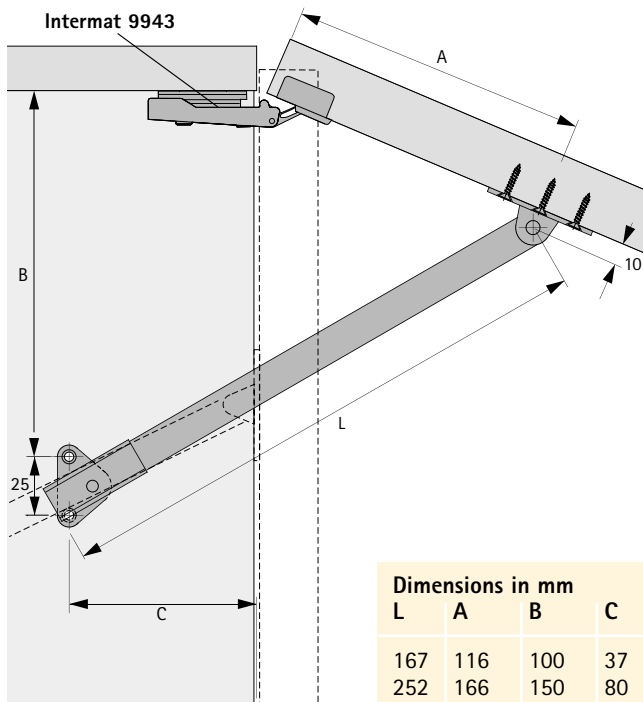

## KLS 40 top box stay

with support head for hole ø 8 mm.

Support bar and base: nickel-plated steel

Support head: white plastic

Flap weight max. 6 kg



| Article      | Order no. | PU     |
|--------------|-----------|--------|
| KLS 40 right | 025 086   | 10 pcs |
| KLS 40 left  | 025 085   | 10 pcs |

## Mounting example

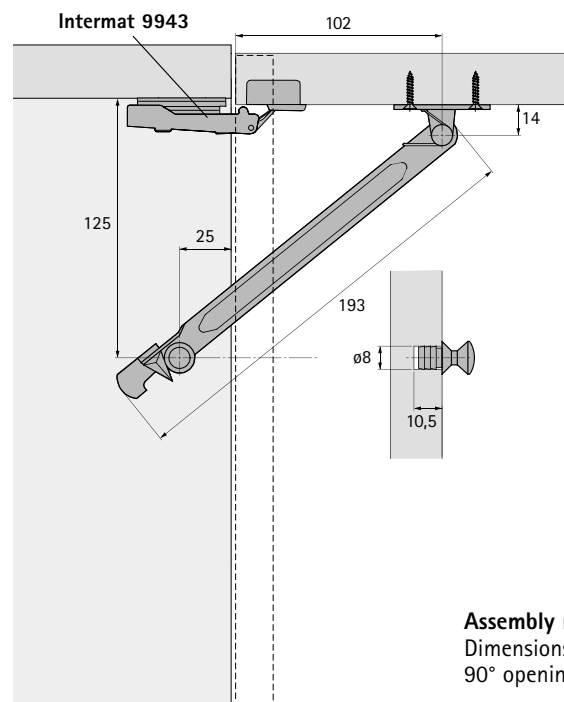

# Top box stays

## KLS 10/200 top box stay with screw-on housing and base

The flap is held open by a catch. Lifting the flap slightly releases the catch. An indent in the tie bar keeps the lid shut.

Support bar, support and base: nickel-plated steel

Housing: white plastic

Flap weight max. 6 kg



## KLS 30/250 top box stay with screw-on support and base

The flap weight is balanced by a spring and the flap is held securely closed.

Adjustable spring force

Nickel-plated steel



3

| Article    | Order no. | PU     |
|------------|-----------|--------|
| KLS 10/200 | 013 239   | 10 pcs |

| Article    | Order no. | PU     |
|------------|-----------|--------|
| KLS 30/250 | 016 179   | 10 pcs |

### Mounting example

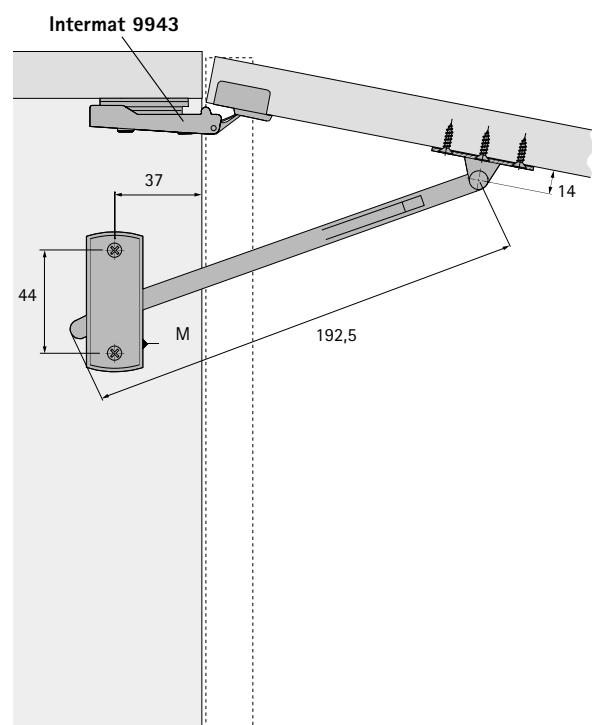

### Mounting example

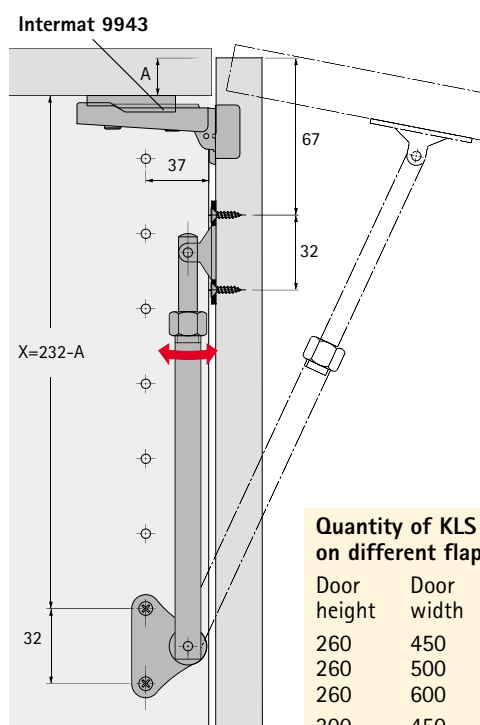

**Assembly note:**  
The ridge M must always be in front at the bottom.

**Assembly note:**  
Increasing X slightly decreases the opening angle.

#### Quantity of KLS 30 to be used on different flap sizes

| Door height | Door width | Material thickness |        |
|-------------|------------|--------------------|--------|
|             |            | 16 mm*             | 19 mm* |
| 260         | 450        | 1                  |        |
| 260         | 500        | 1                  |        |
| 260         | 600        | 1                  |        |
| 300         | 450        | 1                  | 1      |
| 300         | 500        | 1                  | 1      |
| 300         | 600        | 1                  | 1      |
| 400         | 450        | 1                  | 1      |
| 400         | 500        | 1                  | 1      |
| 400         | 600        | 1                  | 2      |
| 500         | 450        | 2                  | 2      |
| 500         | 500        | 2                  | 2      |
| 500         | 600        | 2                  | 2      |

\* based on chipboard

# Lift junior 90/140

## Top box flap support

### 90 N / 140 N spring force

### Opening angle 75°



#### Lift junior 90/140 top box flap support in slender design

90 N / 140 N spring force,  
75° opening angle

The slender and compact top box hinge which takes up minimum space inside the cabinet.

Efficient hole line assembly.

#### Max. flap weight

Lift junior 90: 2 kg

Lift junior 140: 2,5 kg

Nickel-plated steel



Top box flap support available only as a set consisting of a left-hand and right-hand fitting.

| Article         | Order no. | PU      |
|-----------------|-----------|---------|
| Lift junior 90  | 079 397   | 10 sets |
| Lift junior 140 | 040 722   | 10 sets |

3

#### Mounting example

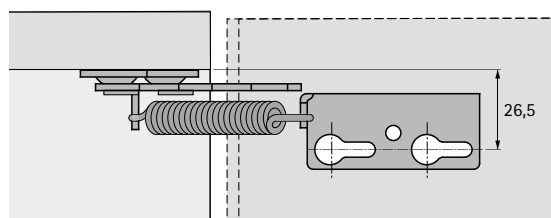
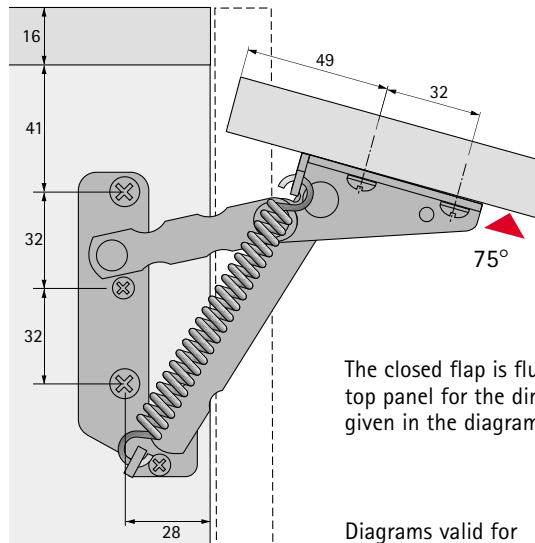
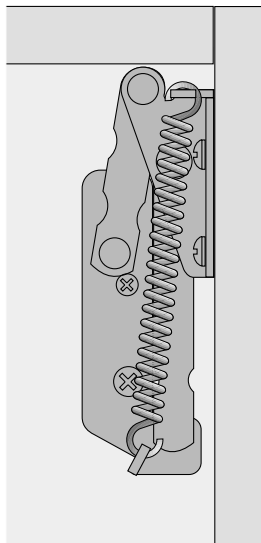

# Lift exact Top box flap support Opening angle 75°



## Lift exact top box flap support variable spring force adjustment, ultimate functionality and maximum safety

The spring can be adjusted up to 220 N to balance the flap weight. This ensures a smooth swinging action and optimal closing and holding forces.

The 75° opening angle swings the flap safely out of harm's way to provide easy access to the cabinet interior.

The spring is mounted absolutely securely.

Efficient hole line assembly.

**Max. flap weight: 4,6 kg**

Nickel-plated steel



Top box flap support available only as a set consisting of a left-hand and right-hand fitting.

| Article    | Order no. | PU      |
|------------|-----------|---------|
| Lift exact | 040 721   | 10 sets |

## Guide values for flap sizes

Flap thickness: 19 mm

Flap material: chipboard

Apparent chipboard density : 0,7 kg/dm<sup>3</sup>

| Height \ Width | 300 | 400 | 450 | 500 | 600 | 700 | 800 | 900 | 1000 |
|----------------|-----|-----|-----|-----|-----|-----|-----|-----|------|
| 200            | ●   | ●   | ●   | ●   | ●   | ●   | ●   | ●   | ●    |
| 250            | ●   | ●   | ●   | ●   | ●   | ●   | ●   | ●   | ●    |
| 300            | ●   | ●   | ●   | ●   | ●   | ●   | ●   | ●   | ●    |
| 350            | ●   | ●   | ●   | ●   | ●   | ●   | ●   | ●   | ●    |
| 400            | ●   | ●   | ●   | ●   | ●   | ●   | ●   | ●   | ■    |
| 450            | ●   | ●   | ●   | ●   | ●   | ●   | ■   | ■   | ■    |
| 500            | ●   | ●   | ●   | ●   | ●   | ■   | ■   | ■   | ■    |

Trial mounting is advisable if necessary.

## Mounting example

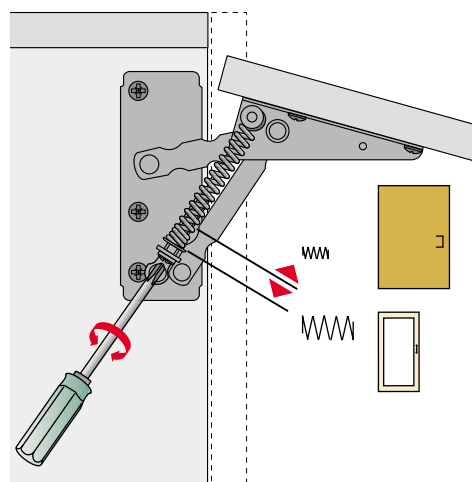
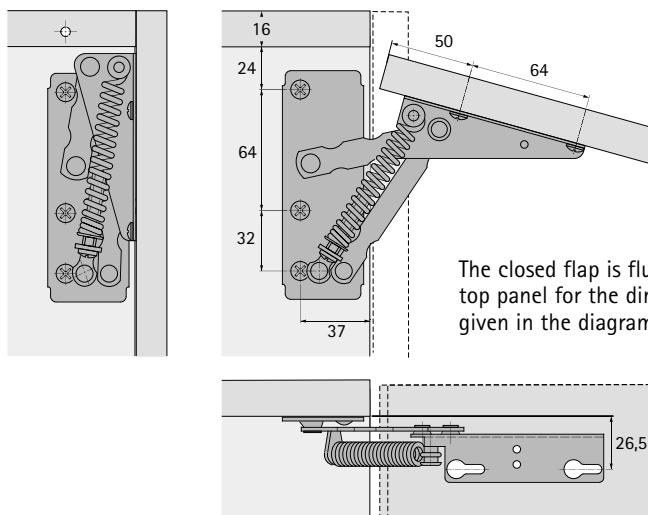

# Lift 90

## Top box flap support

### Opening angle 90°



#### Lift 90 top box flap support

180 N spring force, or infinitely adjustable from 80 to 220 N  
Opening angle 90°

The flap swings open 90° and is held open in this position to provide optimal access to the cabinet interior.

Efficient hole line assembly.

Nickel-plated steel



Top box flap support available only as a set consisting of a left-hand and right-hand fitting.

| Article  | Order no. | max. flap weight | PU      |
|--|-----------|------------------|---------|
| Lift 90, spring force 180 N                                  | 079 389   | 3,3 kg           | 10 sets |
| Lift 90, spring force infinitely adjustable from 80 to 220 N | 010 921   | 4,6 kg           | 10 sets |

#### Guide values for flap sizes

Flap thickness: 19 mm

Flap material: chipboard

Apparent chipboard density : 0,7 kg/dm<sup>3</sup>

① only with infinitely variable spring force adjustment from 80 to 220 N on Lift 90

| Height \ Width | 300 | 400 | 450 | 500 | 600 | 700 | 800 | 900 | 1000 |
|----------------|-----|-----|-----|-----|-----|-----|-----|-----|------|
| 200            | ●   | ●   | ●   | ●   | ●   | ●   | ●   | ●   | ●    |
| 250            | ●   | ●   | ●   | ●   | ●   | ●   | ●   | ●   | ●    |
| 300            | ●   | ●   | ●   | ●   | ●   | ●   | ●   | ●   | ●    |
| 350            | ●   | ●   | ●   | ●   | ●   | ●   | ●   | ●   | ●    |
| 400            | ●   | ●   | ●   | ●   | ●   | ●   | ●   | ①   | ■    |
| 450            | ●   | ●   | ●   | ●   | ●   | ①   | ■   | ■   | ■    |
| 500            | ●   | ●   | ●   | ①   | ①   | ■   | ■   | ■   | ■    |

Trial mounting is advisable if necessary.

#### Mounting example

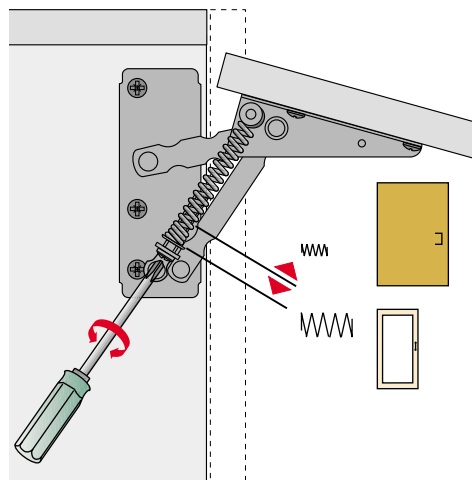
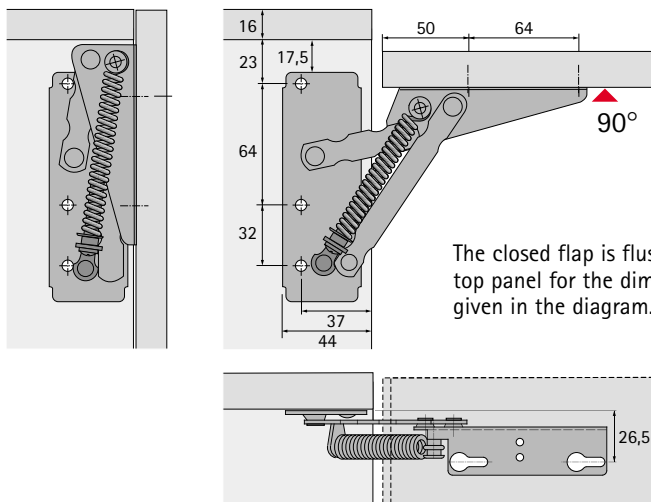

# Aluminium frame profile

## Width 55 mm, curved

### for top box flap support Lift 90

Can be customised to size or supplied ready made up



This profile can be customised to size by the customer.

- Silver anodised surface
- Usable with 4 and 5 mm glass thickness
- Can be cut to individually required lengths
- Safe installation with fixing angles and screws

**Cross-section**

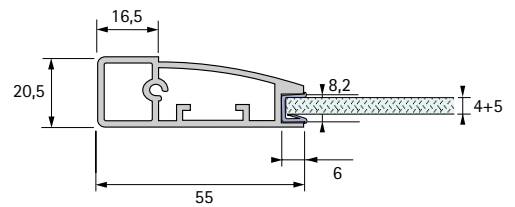

**Aluminium frame profile**  
width 55 mm, curved  
silver anodised



**Sealing strip**  
for glass thickness 4 and 5 mm  
Plastic, transparent



**Angle set**

contains:  
4 fixing angles  
8 fixing screws



| Length  | Order no. | PU |
|---------|-----------|----|
| 6000 mm | 013 430   | 4  |
| 3000 mm | 020 035   | 4  |

| Length  | Order no. | PU |
|---------|-----------|----|
| 3500 mm | 075 620   | 1  |

| Article   | Order no. | PU    |
|-----------|-----------|-------|
| Angle set | 013 684   | 1 set |

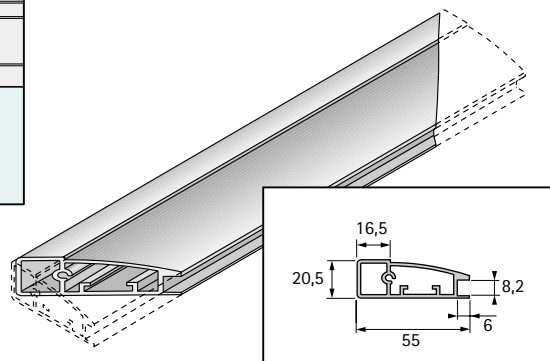
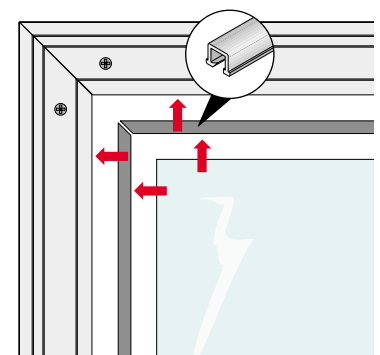
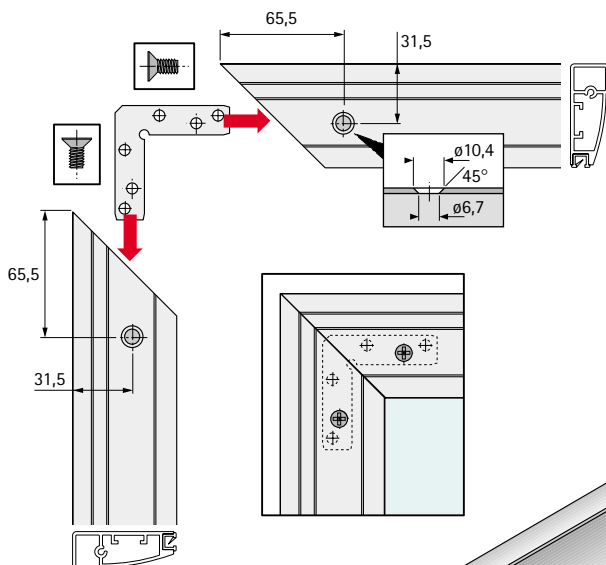

**Glass cutting dimension =**  
door width/height - 102 mm

# Fax order to your specialist retailer

Simply fill in the fax form to receive a set of aluminium frame profiles fully customised to your dimensions, width 55 mm, curved

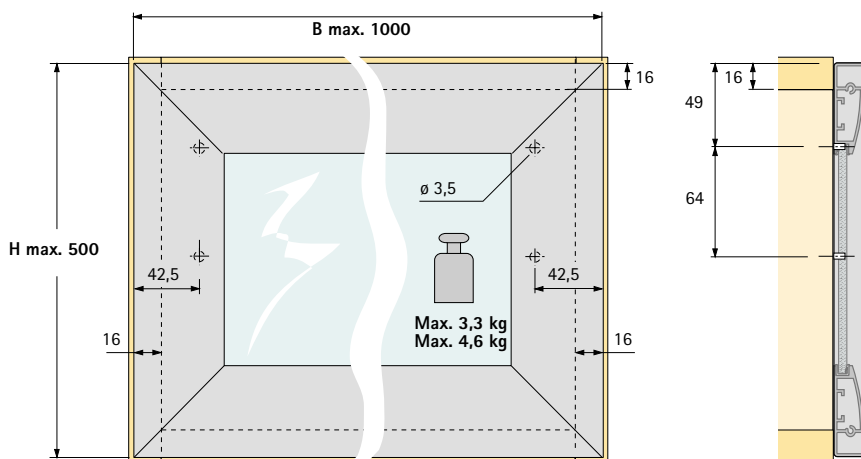

## Attention:

Use a separate order sheet for each frame size/door size. Please specify all measurements in mm!

|                        |  |
|------------------------|--|
| <b>H</b><br>max. 500   |  |
| <b>B</b><br>max. 1000  |  |
| <b>Number of doors</b> |  |

### Aluminium frame profile set, width 55 mm, curved made to measure

contains: 4 aluminium frame profiles, silver anodised  
4 sealing profiles for 4 mm and 5 mm gauge glass

| Order no. | PU    | Door perimeter mm | Number of doors |
|-----------|-------|-------------------|-----------------|
| 041 283   | 1 set |                   |                 |

### Fabrication for an aluminium frame, width 55 mm, curved

contains: mitre cuts, including cutting to length  
drill holes for mitre joint  
4 angle connectors  
8 countersunk screws

| Order no. | PU | Number of doors |
|-----------|----|-----------------|
| 041 287   | 1  |                 |

### Fabrication Lift 90 top box hinge (for one door)

contains: 4 drill holes

| Order no. | PU | Number of doors |
|-----------|----|-----------------|
| 041 596   | 1  |                 |

### Top box flap support Lift 90

Opening angle 90°

| Order no. | Max. flap weight | Stock    | Order quantity |
|-----------|------------------|----------|----------------|
| 079 389   | 3,3 kg           | Retailer |                |
| 010 921   | 4,6 kg           | Retailer |                |

### Special countersunk self-tapping screw

ø 4,8 x 13 mm

| Order no. | Stock    | Order quantity |
|-----------|----------|----------------|
| 041 329   | Retailer |                |

Joiner/interior fitter:

Date: \_\_\_\_\_ Signature: \_\_\_\_\_

# Aluminium frame profile

## Width 55 mm, straight

### for top box flap support Lift 90

Can be customised to size or supplied ready made up



This profile can be customised to size by the customer.

- Silver anodised surface
- Usable with 4 mm glass thickness
- Can be cut to individually required lengths
- Safe installation with fixing angles and screws

Cross-section

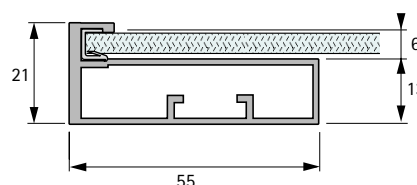

3

#### Aluminium frame profile set

contains:

- 1 aluminium frame profile, silver anodised
- 1 sealing strip for glass thickness 4 mm
- Plastic, transparent



#### Angle set

contains:

- 4 fixing angles
- 8 fixing screws



| Length mm | Order no. | PU    |
|-----------|-----------|-------|
| 3000      | 020 401   | 1 set |

| Article   | Order no. | PU    |
|-----------|-----------|-------|
| Angle set | 013 684   | 1 set |

#### Assembly of aluminium frame profile, width 55 mm

Glass cutting dimension =  
door width/height - 7 mm

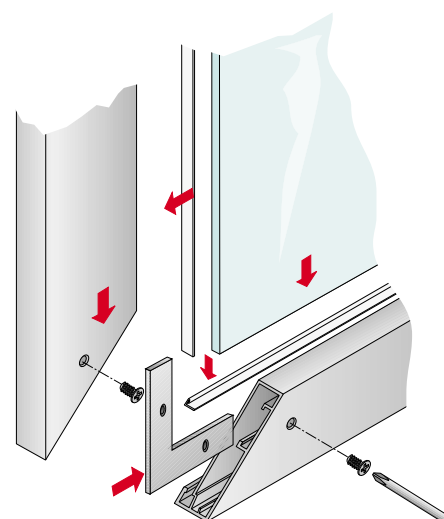
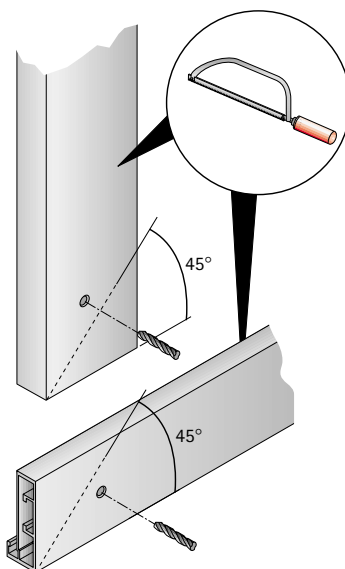
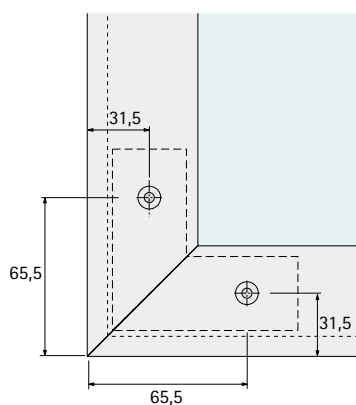

# Fax order to your specialist retailer

Simply fill in the fax form to receive a set of aluminium frame profiles fully customised to your dimensions, width 55 mm, straight

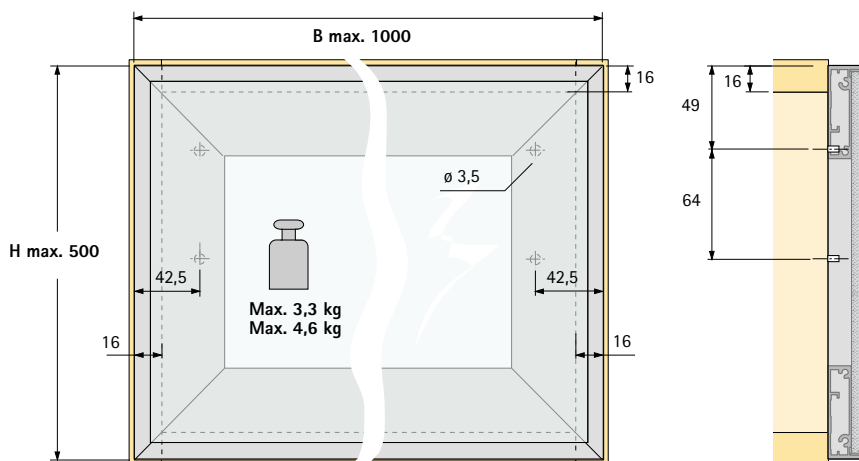

### Attention:

Use a separate order sheet for each frame size/door size. Please specify all measurements in mm.

|                        |  |
|------------------------|--|
| <b>H</b><br>max. 500   |  |
| <b>B</b><br>max. 1000  |  |
| <b>Number of doors</b> |  |

### Aluminium frame profile set, width 55 mm, straight made to measure

contains: 4 aluminium frame profiles, silver anodised  
4 sealing profiles for 4 mm gauge glass

| Order no. | PU    | Door perimeter mm | Number of doors |
|-----------|-------|-------------------|-----------------|
| 041 284   | 1 set |                   |                 |

### Fabrication for an aluminium frame, width 55 mm, straight

contains: mitre cuts, including cutting to length  
drill holes for mitre joint  
4 angle connectors  
8 countersunk screws

| Order no. | PU | Number of doors |
|-----------|----|-----------------|
| 041 288   | 1  |                 |

### Fabrication Lift 90 top box hinge (for one door)

contains: 4 drill holes

| Order no. | PU | Number of doors |
|-----------|----|-----------------|
| 041 595   | 1  |                 |

### Top box flap support Lift 90

Opening angle 90°

| Order no. | Max. flap weight | Stock    | Order quantity |
|-----------|------------------|----------|----------------|
| 079 389   | 3,3 kg           | Retailer |                |
| 010 921   | 4,6 kg           | Retailer |                |

### Special countersunk self-tapping screw

ø 4,8 x 13 mm

| Order no. | Stock    | Order quantity |
|-----------|----------|----------------|
| 041 329   | Retailer |                |

Joiner/interior fitter:

Date: \_\_\_\_\_ Signature: \_\_\_\_\_

# Lift 90 Alu

## Top box flap support

### 90° opening angle

### Adjustable spring force



#### Lift 90 Alu top box flap support for use with aluminium frame doors

The spring force is infinitely adjustable from 80 N to 220 N to balance the flap weight  
90° opening angle

The aluminium frame door swings open 90° and is held open in this position to provide optimal access to the cabinet interior.

**Max. flap weight: 4,6 kg**  
Nickel-plated steel

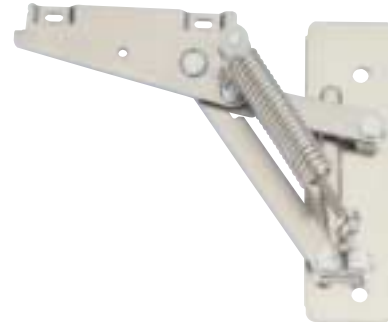

3

Top box flap support available only as a set consisting of a left-hand and right-hand fitting.

| Article     | Order no. | PU      |
|-------------|-----------|---------|
| Lift 90 Alu | 079 390   | 10 sets |

#### Profile set, contains:

- 2 aluminium cross profiles
- silver anodised
- 2 x sealing strip



| Order no. | Profile mm | PU set |
|-----------|------------|--------|
| 079 682   | 294        | 1      |
| 079 683   | 394        | 1      |
| 079 684   | 494        | 1      |
| 079 685   | 594        | 1      |
| 013 639   | 3000       | 1      |

#### Angle set

- contains:
- 4 fixing angles
- 8 fixing screws

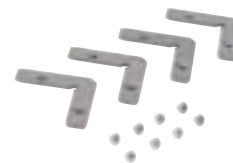

| Article   | Order no. | PU    |
|-----------|-----------|-------|
| Angle set | 079 686   | 1 set |

#### Mounting example

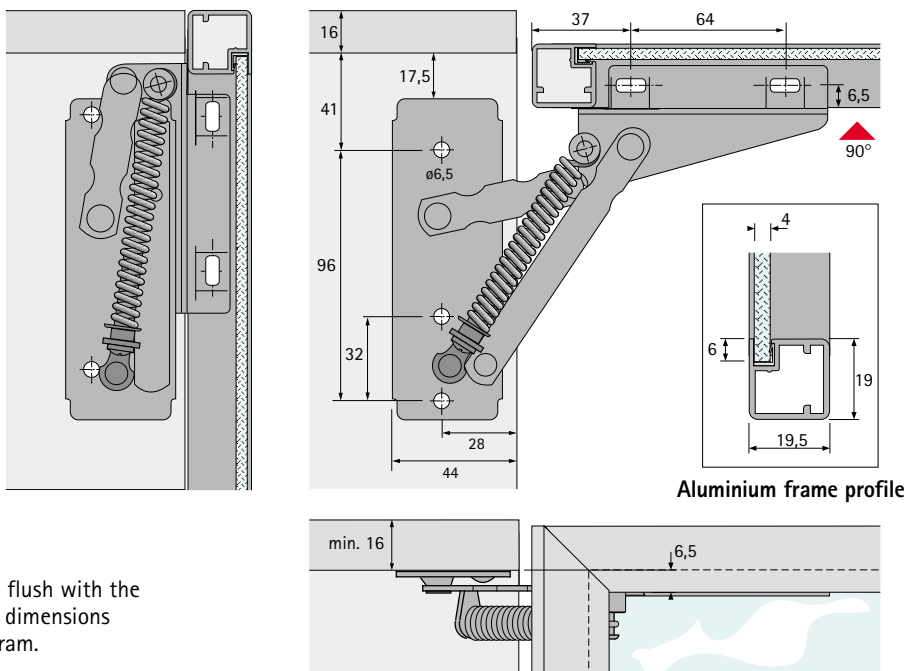

The closed flap is flush with the top panel for the dimensions given in the diagram.

# Fax order to your specialist retailer

Simply fill in the fax form to receive a set of aluminium frame profiles fully customised to your dimensions, width 19 mm

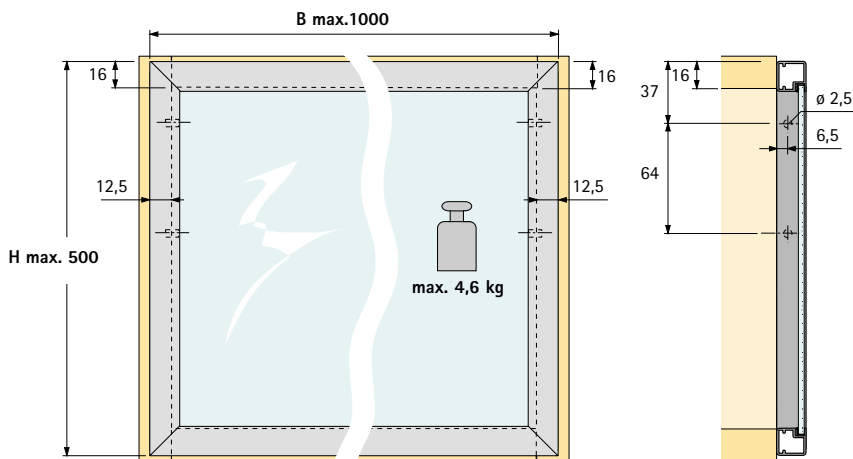

### Attention:

Use a separate order sheet for each frame size/door size. Please specify all measurements in **mm**.

|                        |  |
|------------------------|--|
| <b>H</b><br>max. 500   |  |
| <b>B</b><br>max. 1000  |  |
| <b>Number of doors</b> |  |

### Aluminium frame profile set, width 19 mm made to measure

contains: 4 aluminium frame profiles, silver anodised  
4 sealing profiles for 4 mm gauge glass

| Order no. | PU    | Door perimeter mm | Number of doors |
|-----------|-------|-------------------|-----------------|
| 041 281   | 1 set |                   |                 |

### Fabrication for an aluminium frame, width 19 mm

contains: mitre cuts, including cutting to length  
drill holes for mitre joint  
4 angle connectors  
8 countersunk screws

| Order no. | PU | Number of doors |
|-----------|----|-----------------|
| 041 285   | 1  |                 |

### Fabrication Lift 90 Alu top box hinge (for one door)

contains: 4 drill holes

| Order no. | PU | Number of doors |
|-----------|----|-----------------|
| 041 595   | 1  |                 |

### Lift 90 Alu top box flap support

Opening angle 90°

| Order no. | Stock    | Order quantity |
|-----------|----------|----------------|
| 079 390   | Retailer |                |

### Special countersunk self-tapping screw

ø 3,9 x 9,5 mm

| Order no. | Stock    | Order quantity |
|-----------|----------|----------------|
| 041 331   | Retailer |                |

Joiner/interior fitter:

Date: \_\_\_\_\_ Signature: \_\_\_\_\_

# Top box Lift Up



## Top box Lift Up

Ideal for microwave ovens, electrical appliances or files

The inset flap is simple to install, saves space, easy to operate and disappears almost completely in the carcass

Suitable for 6 different flap thicknesses

12, 13, 15, 16, 18 and 19 mm

Max. flap width: 1200 mm

Flap heights from 145 to 400 mm

Flap weight max.: 8 kg

Height adjustment  $\pm 1,25$  mm

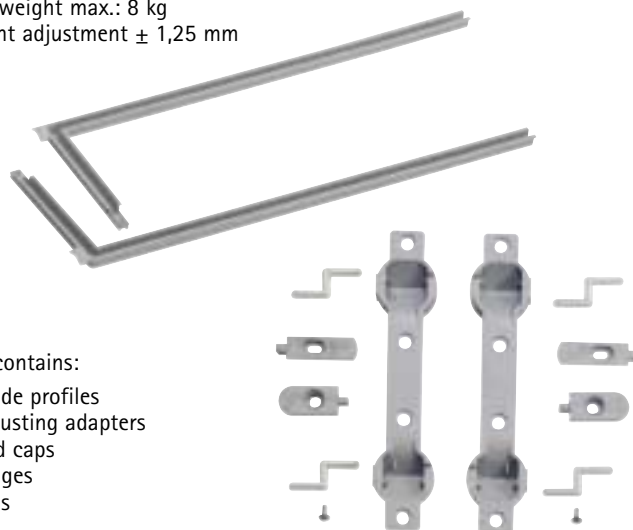

### Set contains:

- 2 guide profiles
- 2 adjusting adapters
- 2 end caps
- 2 hinges
- 4 pins

| Article         | For flap thickness | Order no. | PU    |
|-----------------|--------------------|-----------|-------|
| Top box Lift Up | 12 / 13 mm         | 045 024   | 1 set |
|                 | 15 / 16 mm         | 045 025   | 1 set |
|                 | 18 / 19 mm         | 045 026   | 1 set |

## Mounting example

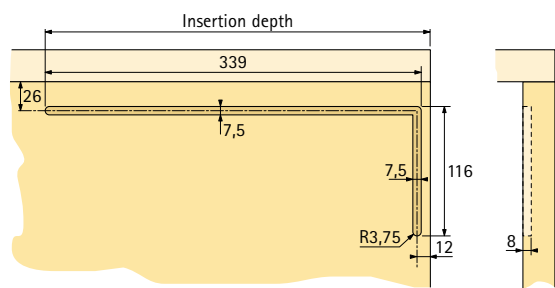

max. insertion depth = 346 mm  
min. insertion depth = 130 mm

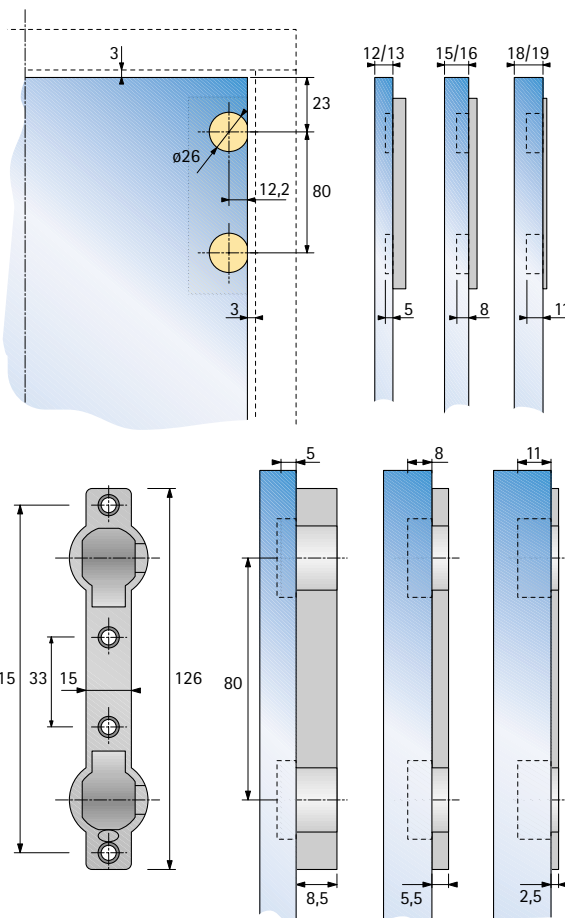
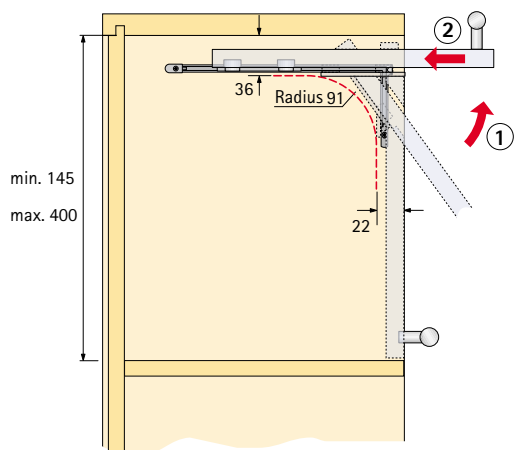

# Assembly

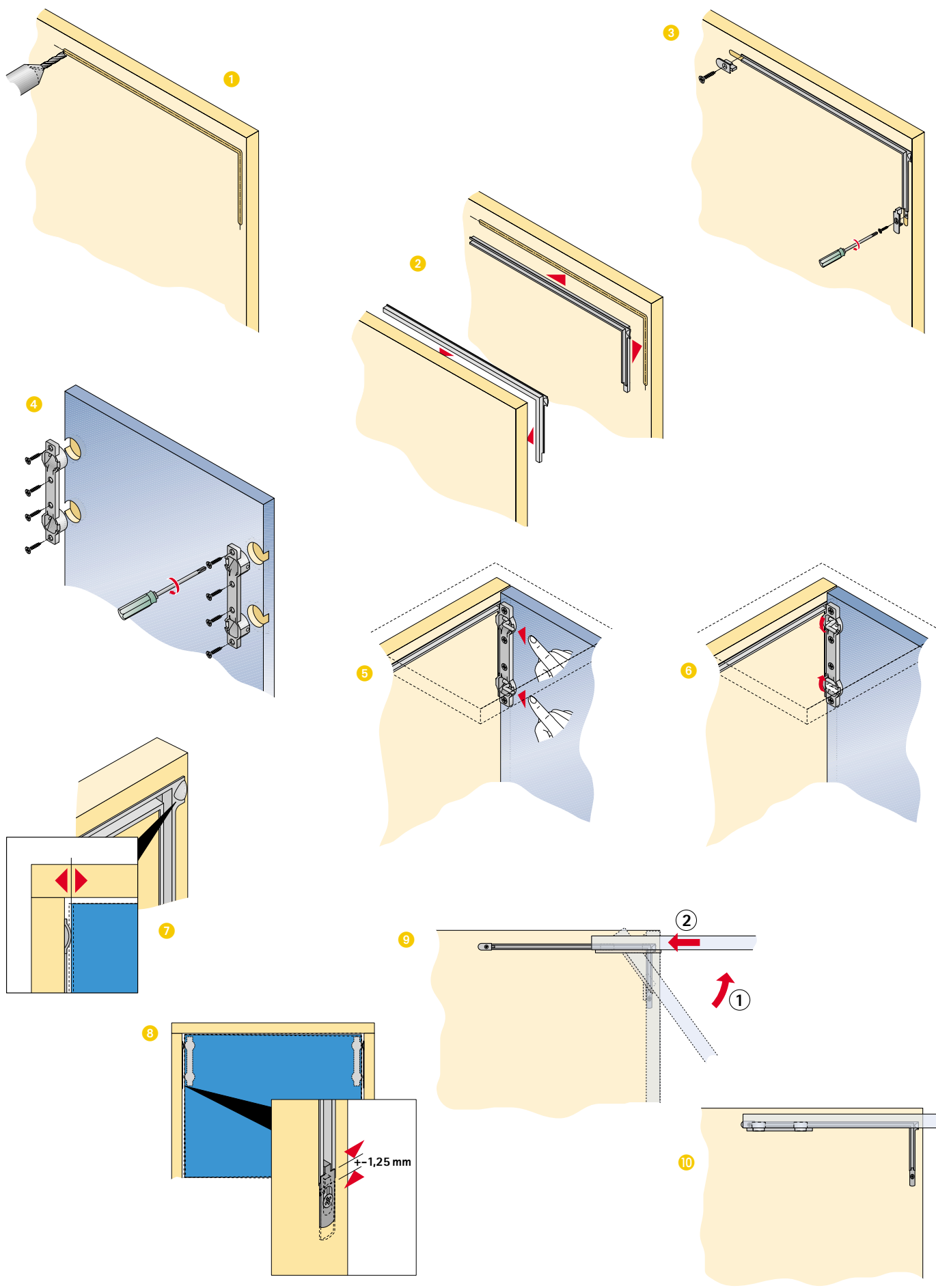

# Ball bearing slide KA 5720

## For overhead applications

### Load-bearing capacity 14 kg



- Ball bearing slide KA 5720 for overhead applications in 7 lengths
- Chromated steel
- Max. door weight 14 kg
- Smooth action and high side stability through precision slide
- With piano hinge 90°
- For door thickness up to 19 mm
- Top panel thickness min. 22 mm



| Article / Nominal length mm | Door height mm | Order no. | PU    |
|-----------------------------|----------------|-----------|-------|
| KA 5720 / 300               | 300            | 041 402   | 1 set |
| KA 5720 / 350               | 350            | 041 403   | 1 set |
| KA 5720 / 400               | 400            | 041 404   | 1 set |
| KA 5720 / 450               | 450            | 041 405   | 1 set |
| KA 5720 / 500               | 500            | 041 406   | 1 set |
| KA 5720 / 550               | 550            | 041 407   | 1 set |
| KA 5720 / 600               | 600            | 041 408   | 1 set |

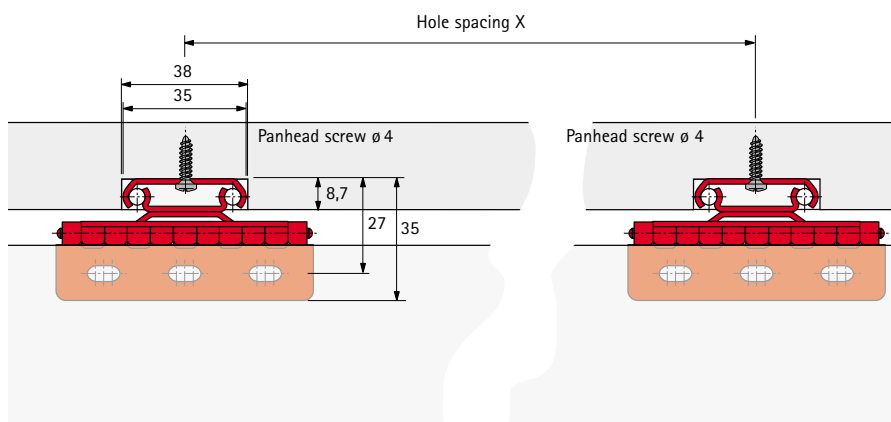

### Mounting

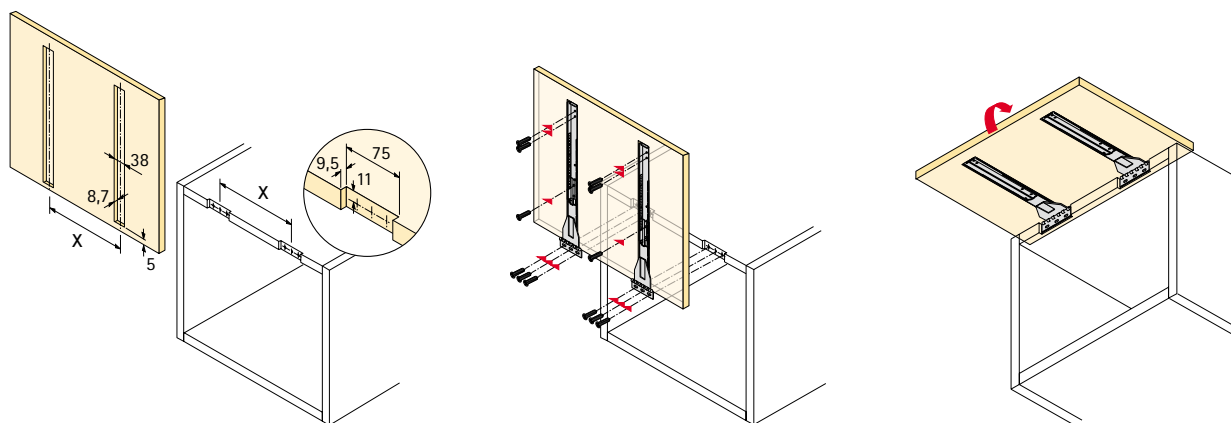

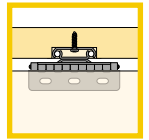

Hole position (mm)

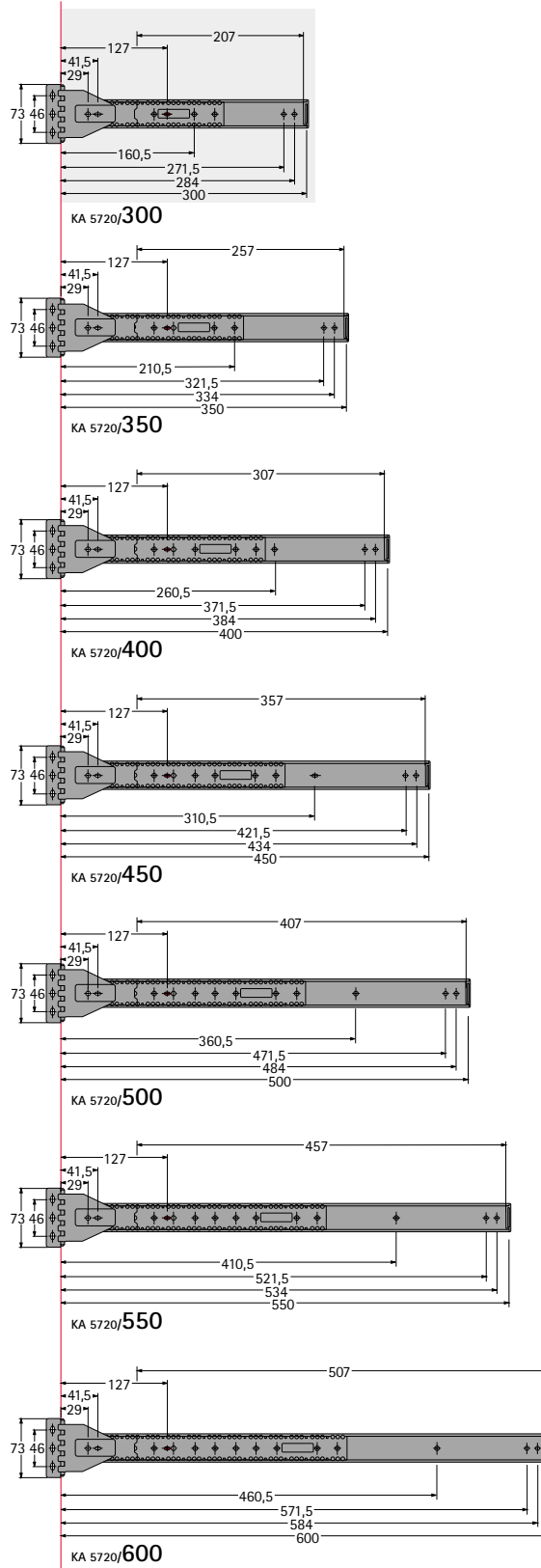

# Vertical lift-up flap fitting with pneumatic action



## Vertical lift-up flap fitting

Ideal for microwave ovens, grills, electrical appliances, etc. The pneumatic action supports the self-acting parallel upward motion of the flap/door and ensures that it is held open safely and closes securely

- Optimal access
- Efficient assembly, the door/flap is simply clipped on and screwed tight
- **Two-dimensional front adjustment**  
Height  $\pm 3$  mm, side  $\pm 3$  mm
- **Max. flap/door weight 4,6 kg**
- **Minimum internal cabinet dimensions:**  
Width: 561/563/567 mm (see table\*)  
Height: min. 330 mm, max. 450 mm  
Depth: min. 215 mm
- Finish: steel, white plastic coated or aluminium finish



| Article                       | For cabinet side mm | * Required inside cabinet width mm | Order no. |                  | PU |
|-------------------------------|---------------------|------------------------------------|-----------|------------------|----|
|                               |                     |                                    | white     | aluminium finish |    |
| Vertical lift-up flap fitting | 16                  | 567                                | 079 392   | 045 027          | 1  |
|                               | 18                  | 563                                | 079 393   | 045 028          | 1  |
|                               | 19                  | 561                                | 079 394   | 045 029          | 1  |

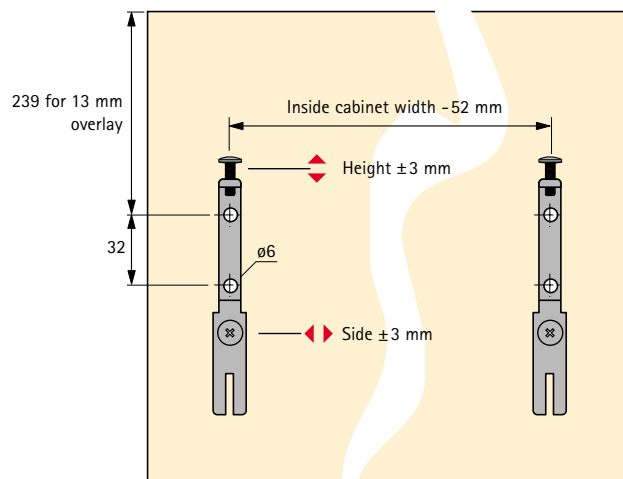
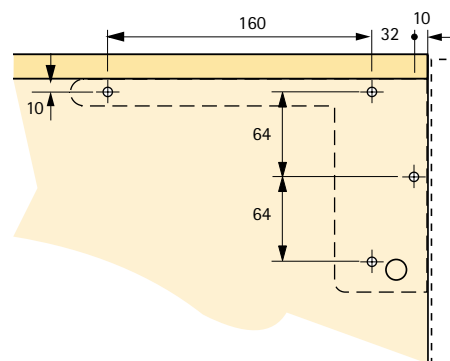
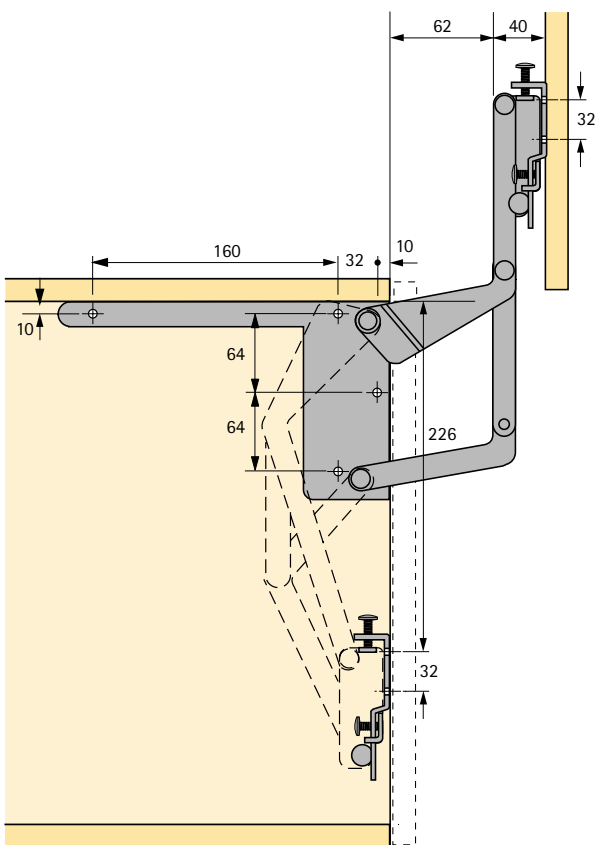

# Vertical lift-up flap fitting with pneumatic action

## Assembly

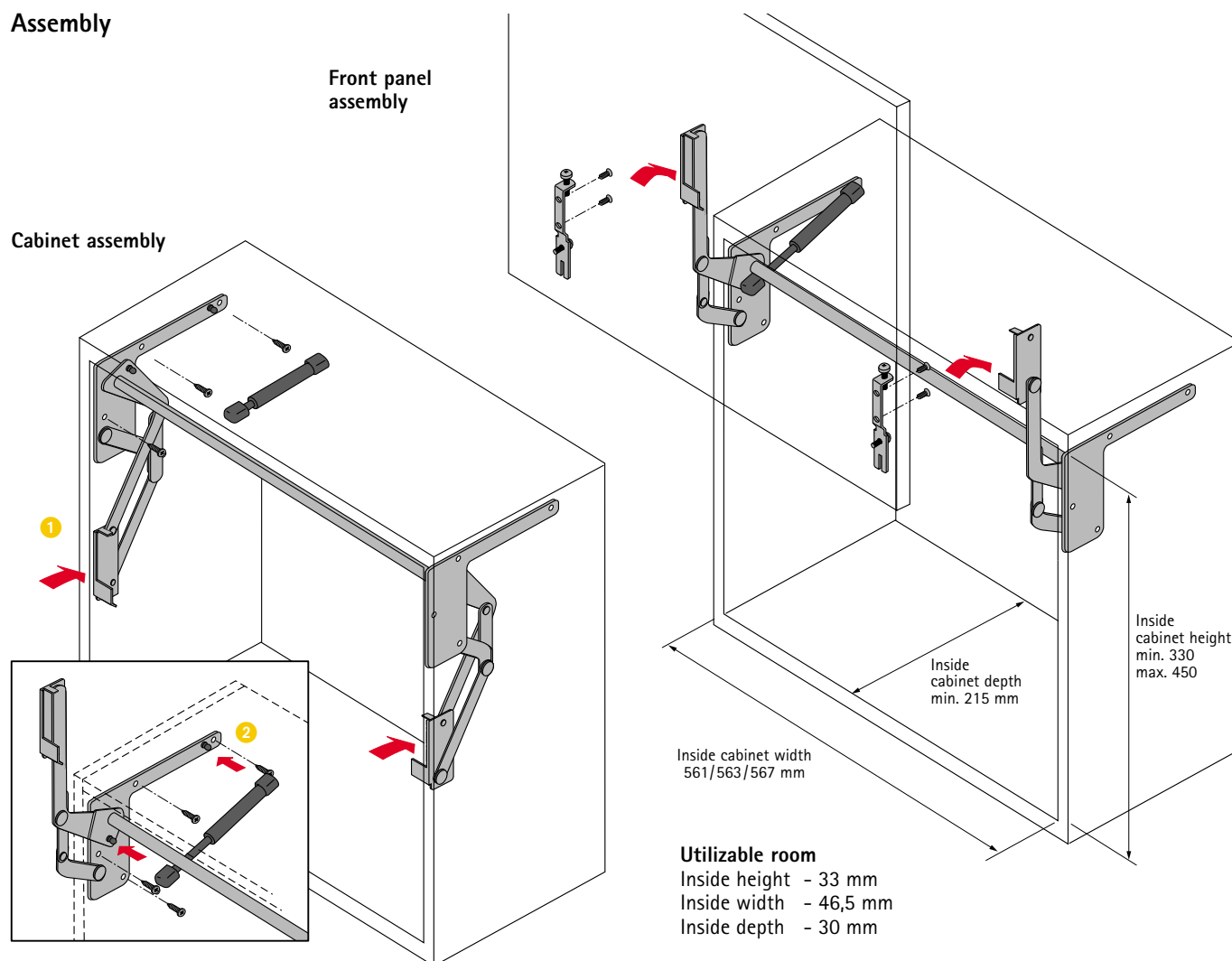

3

## Front panel assembly

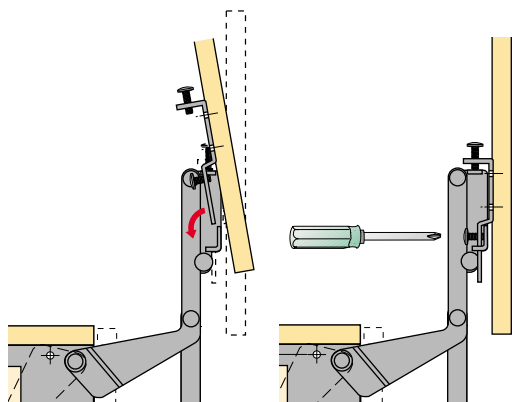

## Front panel adjustment

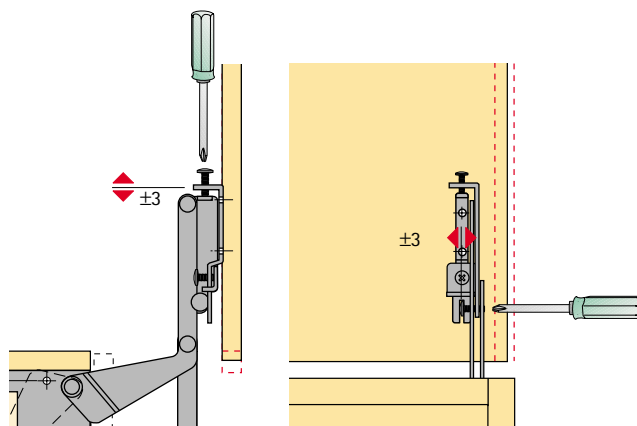

# Vertical lift-up flap fitting with pneumatic action and adjustable width

3



## Vertical lift-up flap fitting with pneumatic action and adjustable width

Ideal for microwave ovens, grills, electrical appliances, etc. The pneumatic action supports the self-acting parallel upward motion of the flap/door and ensures that it is held open safely and closes securely.

- **Adjustable width for inside cabinet width of 411–580 mm / 560–870 mm**
- Dual pneumatic action
- Optimal access
- Efficient assembly, the door/flap is simply clipped on and screwed tight
- **Two-dimensional front adjustment**  
Height  $\pm 3$  mm, side  $\pm 3$  mm
- **Max. flap/door weight 4,0 kg / 5,0 kg**
- **Minimum internal cabinet dimensions:**  
Width: 411–580 mm / 560–870 mm  
Height: min. 330 mm – 450 mm  
Depth: min. 215 mm
- Finish: steel, white plastic coated or aluminium finish



| Article  | Inside cabinet width of | Max. flap weight | Order no. | PU      |                  |
|--|-------------------------|------------------|-----------|---------|------------------|
|  |                         |                  | white     |         | aluminium finish |
| Vertical lift-up flap fitting with pneumatic action and adjustable width | 411 - 580 mm            | 4,0 kg           | 045 159   | 045 031 | 1                |
|  | 560 - 870 mm            | 5,0 kg           | 045 160   | 045 032 | 1                |

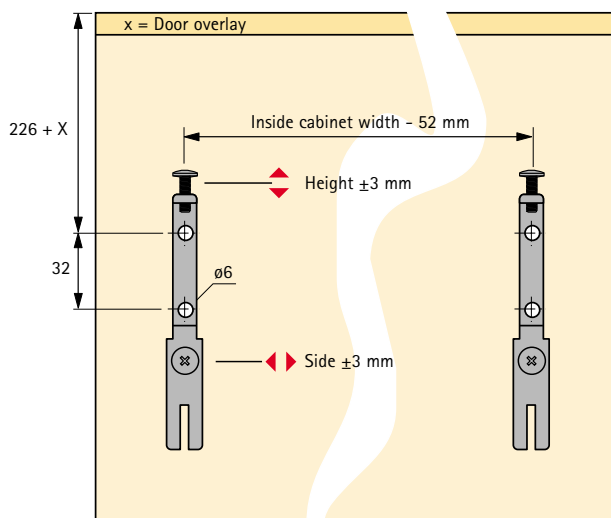
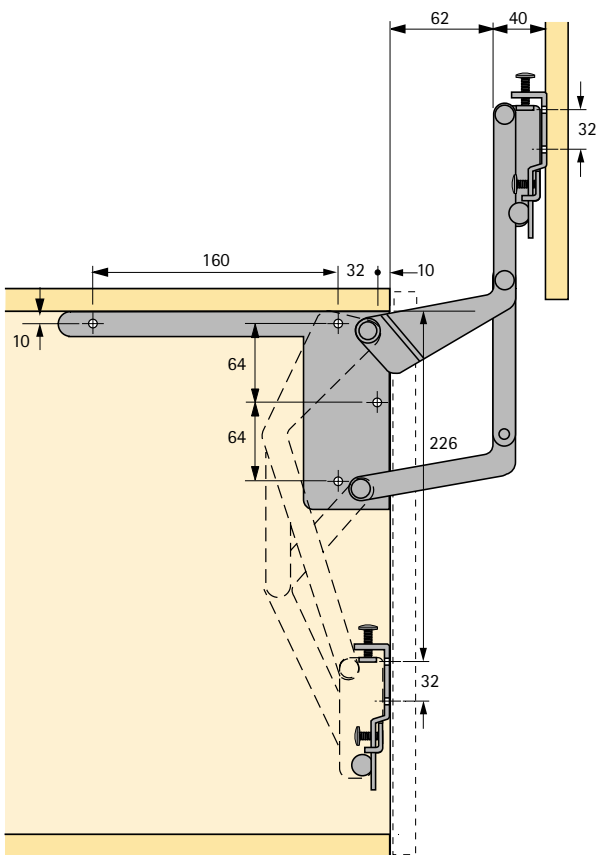

# Vertical lift-up flap fitting with pneumatic action and adjustable width

## Assembly

### Cabinet assembly

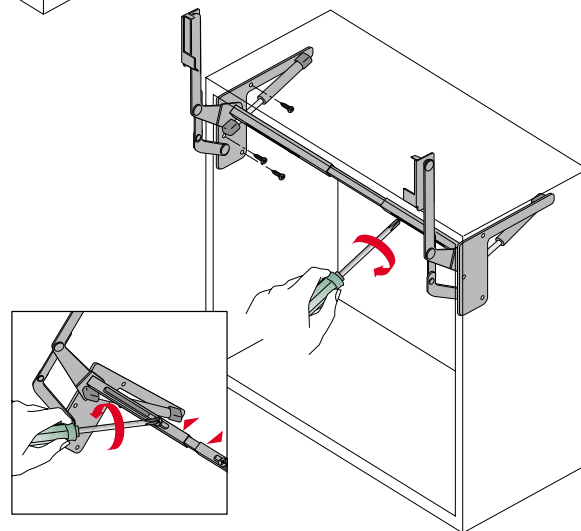
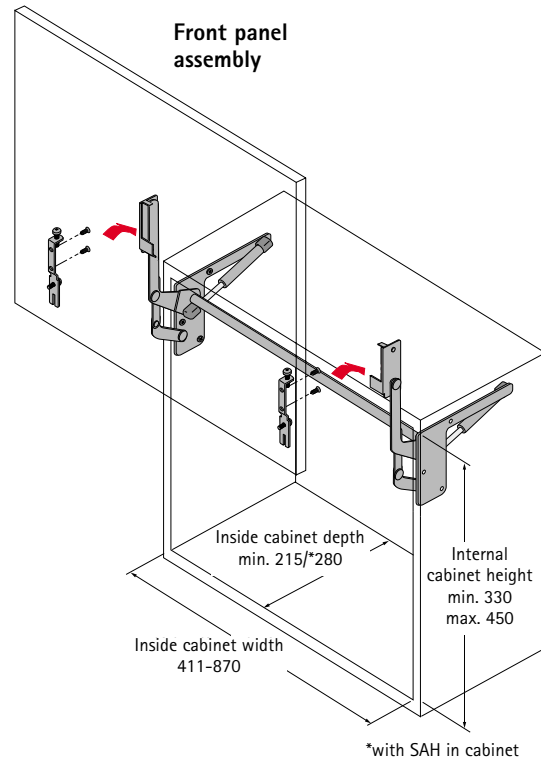
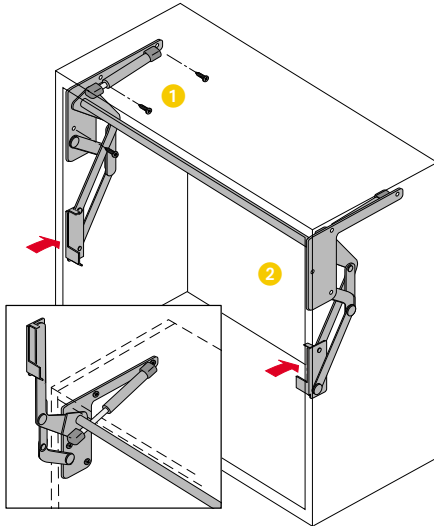

### Utilizable room

Inside height - 35 mm  
 Inside width - 55 mm  
 Inside depth - 30 mm

### Front panel assembly

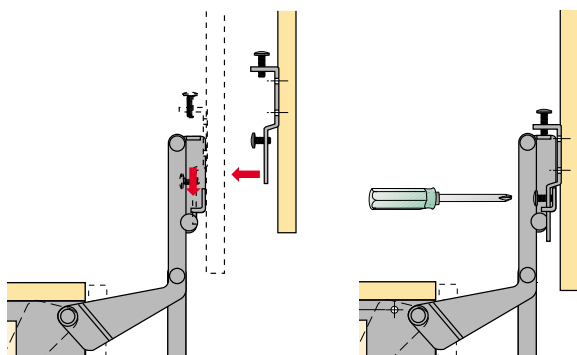

### Front panel adjustment

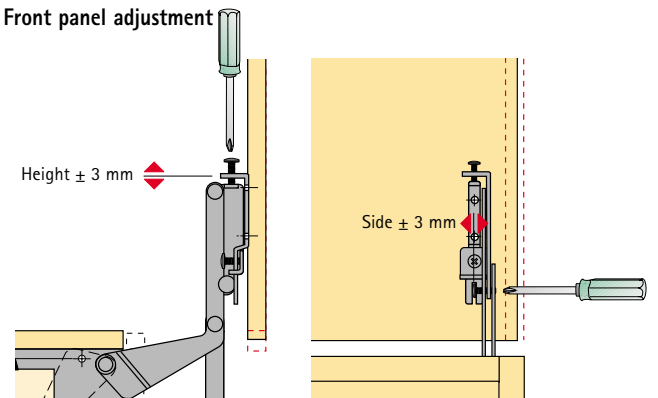

3

# Vertical lift-up flap fitting width adjustable with 2 gas pressure springs



## Adjustable width flap fitting allows doors to lift vertically.

Ideal for microwaves, grills and electrical appliances. The two gas pressure springs assist the mechanism to hold the front securely in the open position and close it firmly. Simply customise the aluminium connecting strut to adjust to individual cabinet widths.

- Adjustable to clear cabinet widths of 450 - 870/1170/1470 mm
- Dual pneumatic action
- Optimal access
- Efficient assembly, the door/flap is simply clipped on and screwed tight
- **Three-dimensional front adjustment**  
Height  $\pm 3$  mm, side  $\pm 1,5$  mm, angle  $-0,5^\circ / +1^\circ$
- **Max. flap/door weight 5,0/7,0/8,5 kg**
- **Minimum internal cabinet dimensions:**  
Width: 450 bis 870/1170/1470 mm  
Height: min. 320 mm  
Depth: min. 220 mm
- Finish: steel, white plastic coated or aluminium finish



3

| Article  | Inside cabinet width | Max. flap weight | Order no. |                  | PU |
|--|----------------------|------------------|-----------|------------------|----|
|  |                      |                  | white     | aluminium finish |    |
| Vertical lift-up flap fitting<br>width adjustable<br>with 2 gas pressure springs | 450 - 870 mm         | 5,0 kg           | 013 886   | 045 033          | 1  |
|  | 450 - 1170 mm        | 7,0 kg           | 013 887   | 045 034          | 1  |
|  | 450 - 1470 mm        | 8,5 kg           | 013 888   | 045 035          | 1  |

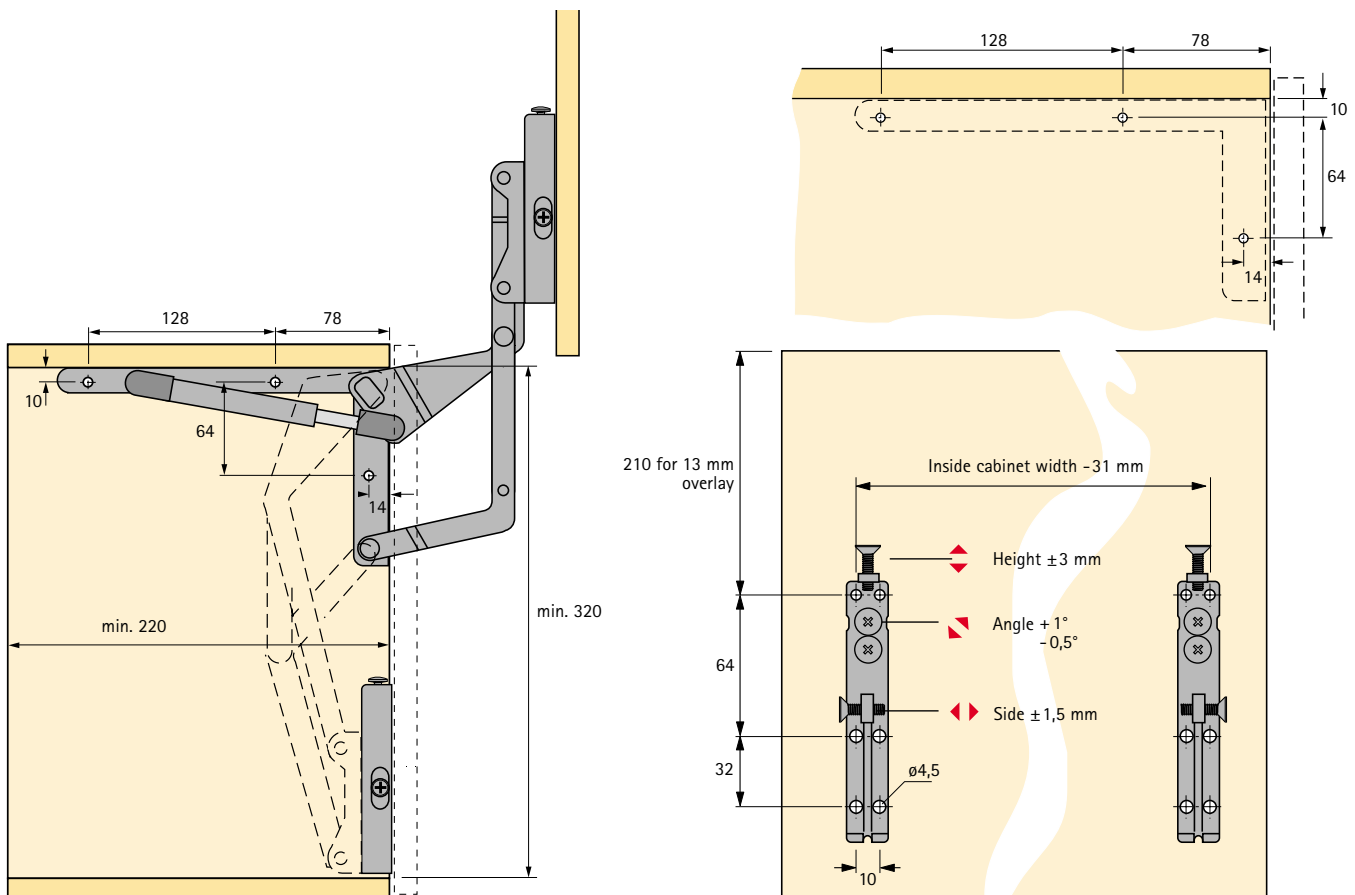

# Vertical lift-up flap fitting width adjustable with 2 gas pressure springs

Assembly

Front panel assembly

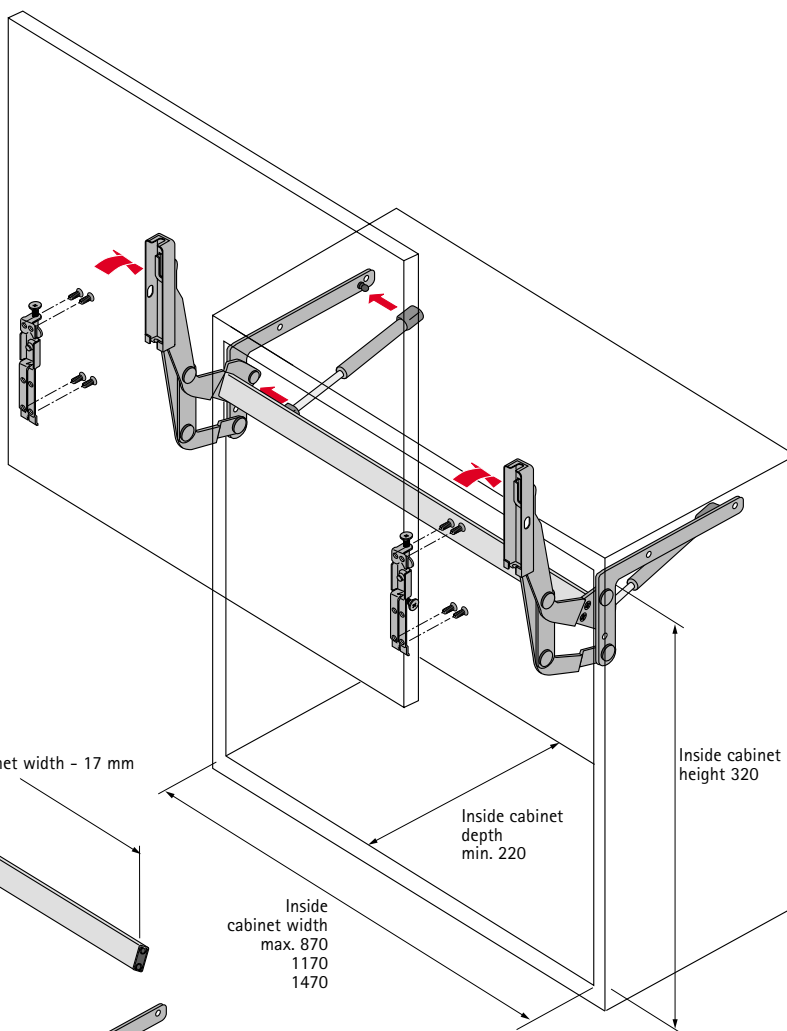

Cabinet assembly

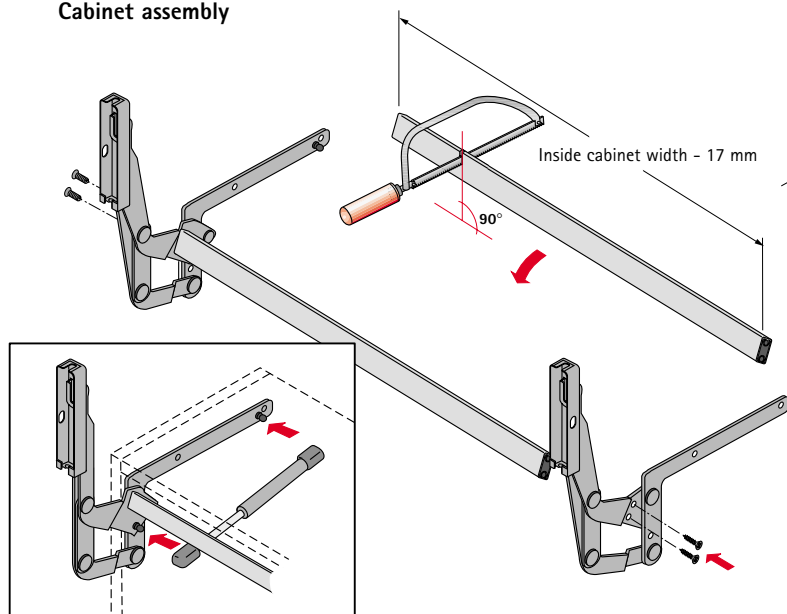

**Utilizable room**  
Inside height - 60 mm  
Inside width - 72 mm

Front panel assembly

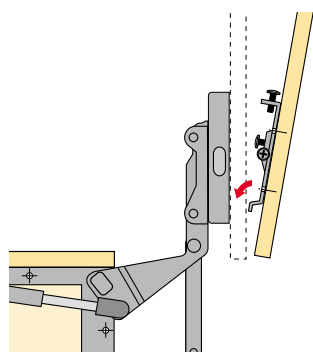

Front panel adjustment

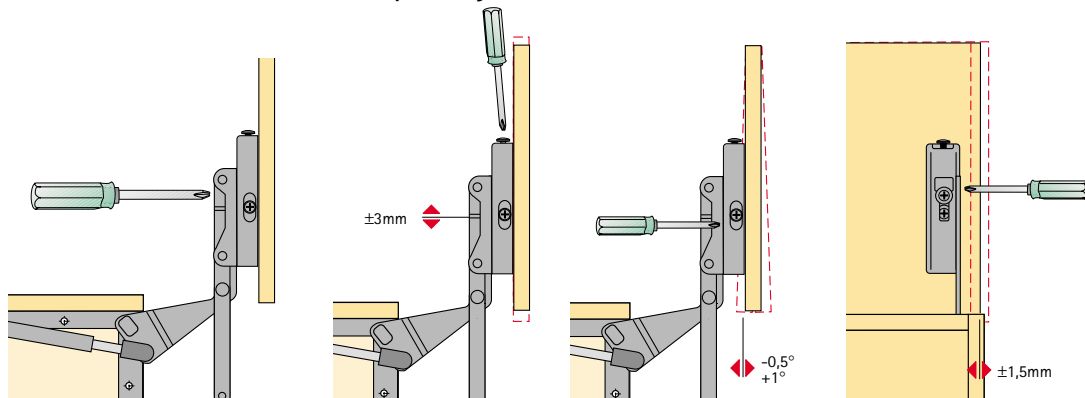

# Aluminium frame profile

## Width 55 mm, curved

### for vertical lift-up flap fitting, width adjustable

Can be customised to size or supplied ready made up



This profile can be customised to size by the customer.

- Silver anodised surface
- Usable with 4 and 5 mm glass thickness
- Safe installation with fixing angles and screws

Cross-section

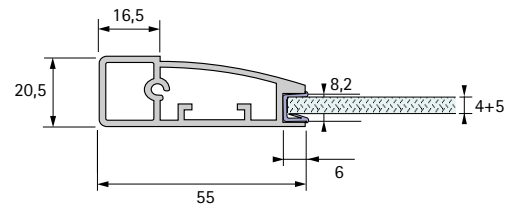

Aluminium frame profile,  
width 55 mm, curved  
silver anodised



Sealing strip  
for glass thickness 4 and 5 mm  
Plastic, transparent



Angle set

contains:  
4 fixing angles  
8 fixing screws



| Length  | Order no. | PU |
|---------|-----------|----|
| 6000 mm | 013 430   | 4  |
| 3000 mm | 020 035   | 4  |

| Length  | Order no. | PU |
|---------|-----------|----|
| 3500 mm | 075 620   | 1  |

| Article   | Order no. | PU    |
|-----------|-----------|-------|
| Angle set | 013 684   | 1 set |

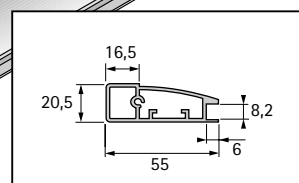
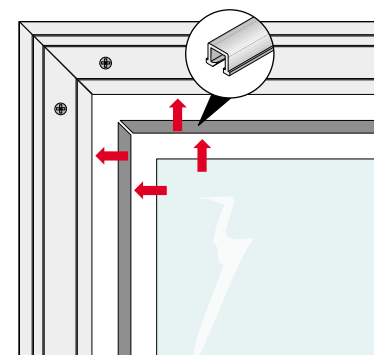
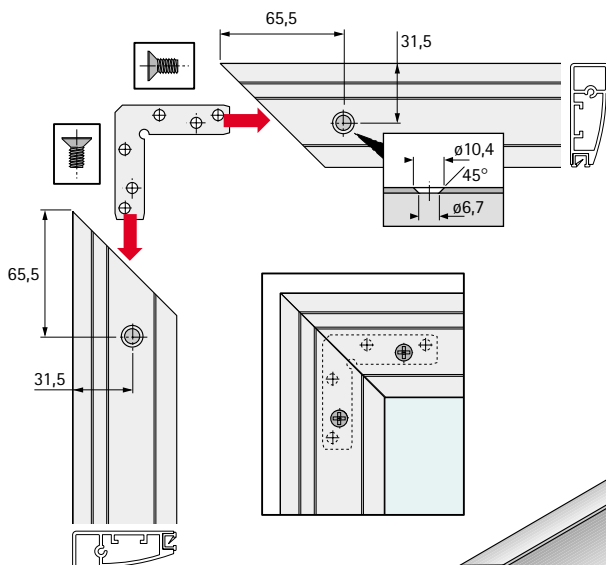

Glass cutting dimension =  
door width/height - 102 mm

# Fax order to your specialist retailer

Simply fill in the fax form to receive a set of aluminium frame profiles fully customised to your dimensions, width 55 mm, curved

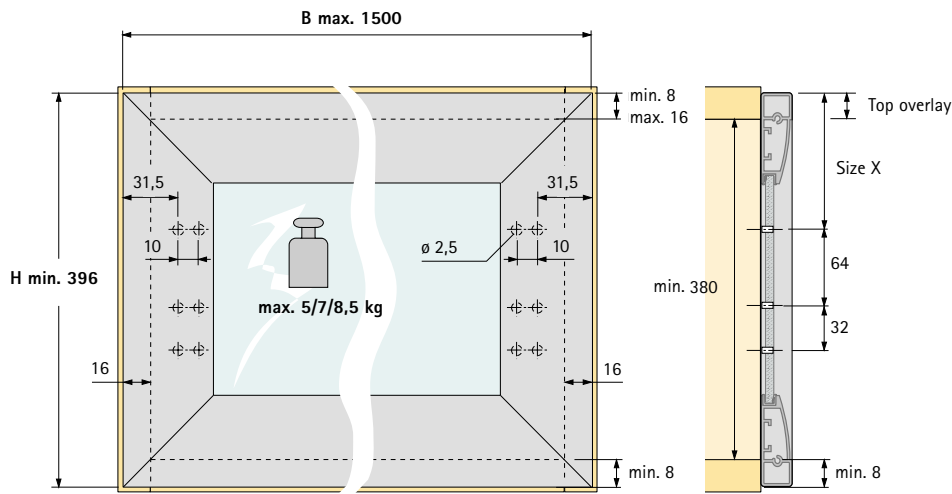

### Attention:

Use a separate order sheet for each frame size/door size. Please specify all measurements in mm.

|                            |  |
|----------------------------|--|
| <b>H</b><br>min. 396       |  |
| <b>B</b><br>max. 1500      |  |
| <b>Size X</b><br>see below |  |
| <b>Number of doors</b>     |  |

|              |     |     |     |     |     |     |     |     |     |
|--------------|-----|-----|-----|-----|-----|-----|-----|-----|-----|
| Side overlay | 16  |     |     |     |     |     |     |     |     |
| Top overlay  | 8   | 9   | 10  | 11  | 12  | 13  | 14  | 15  | 16  |
| Size X       | 205 | 206 | 207 | 208 | 209 | 210 | 211 | 212 | 213 |

### Aluminium frame profile set, width 55 mm, curved made to measure

contains: 4 aluminium frame profiles, silver anodised  
4 sealing profiles for 4 mm and 5 mm gauge glass

| Order no. | PU    | Door perimeter mm | Number of doors |
|-----------|-------|-------------------|-----------------|
| 041 283   | 1 set |                   |                 |

### Fabrication for an aluminium frame, width 55 mm, curved

contains: mitre cuts, including cutting to length  
drill holes for mitre joint  
4 angle connectors  
8 countersunk screws

| Order no. | PU | Number of doors |
|-----------|----|-----------------|
| 041 287   | 1  |                 |

### Fabrication for vertical lift-up flap fitting, width adjustable with 2 gas pressure springs (for one door)

contains: 12 drill holes

| Order no. | PU | Number of doors |
|-----------|----|-----------------|
| 041 597   | 1  |                 |

### Vertical lift-up flap fitting, width adjustable

with pneumatic action

| Order no. | aluminium finish | Inside cabinet width  | Max. flap weight | Stock    | Order quantity |
|-----------|------------------|---|------------------|----------|----------------|
| 013 886   | 045 033          | 450 - 870 mm  | 5,0 kg           | Retailer |                |
| 013 887   | 045 034          | 450 - 1170 mm   | 7,0 kg           | Retailer |                |
| 013 888   | 045 035          | 450 - 1470 mm   | 8,5 kg           | Retailer |                |
| 041 331   |                  | Special countersunk self-tapping screw $\varnothing$ 3,9 x 9,5 mm |                  | Retailer |                |

Joiner/interior fitter:

Date: \_\_\_\_\_ Signature: \_\_\_\_\_

# Aluminium frame profile

## Width 55 mm, straight

### for vertical lift-up flap fitting, width adjustable

Can be customised to size or supplied ready made up



This profile can be customised to size by the customer.

- Silver anodised surface
- Usable with 4 mm glass thickness
- Can be cut to individually required lengths
- Safe installation with fixing angles and screws

Cross-section

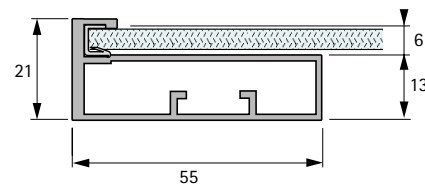

3

#### Aluminium frame profile set, width 55 mm, straight

contains:

- 1 aluminium frame profile, silver anodised
- 1 sealing strip for glass thickness 4 mm
- Plastic, transparent



#### Angle set

contains:

- 4 fixing angles
- 8 fixing screws

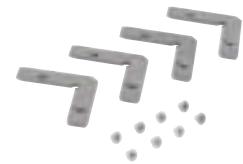

| Length mm | Order no. | PU    |
|-----------|-----------|-------|
| 3000      | 020 401   | 1 set |

| Article   | Order no. | PU    |
|-----------|-----------|-------|
| Angle set | 013 684   | 1 set |

#### Assembly of aluminium frame profile, width 55 mm

Glass cutting dimension = door width/height - 7 mm

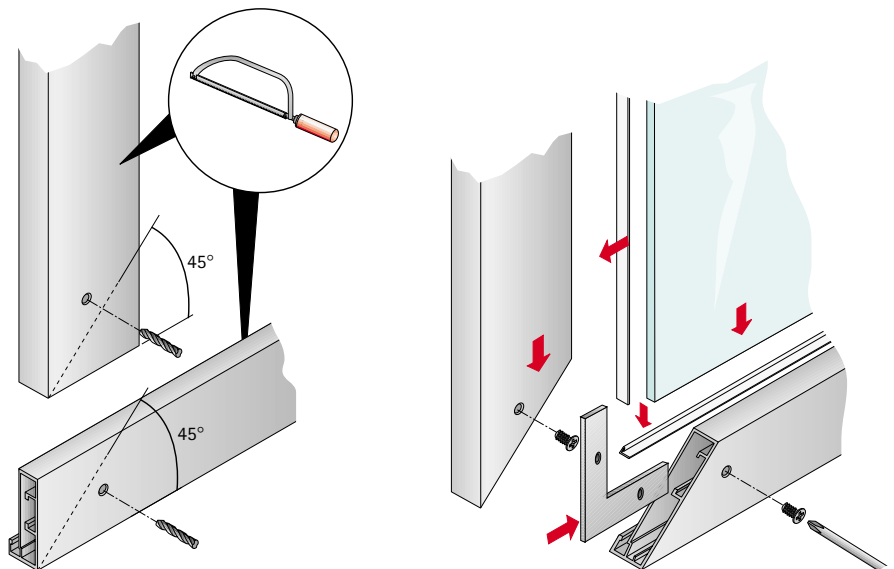
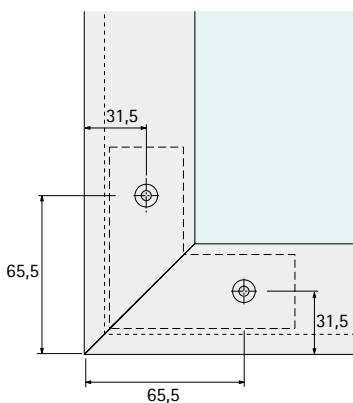

# Fax order to your specialist retailer

Simply fill in the fax form to receive a set of aluminium frame profiles fully customised to your dimensions, width 55 mm, straight

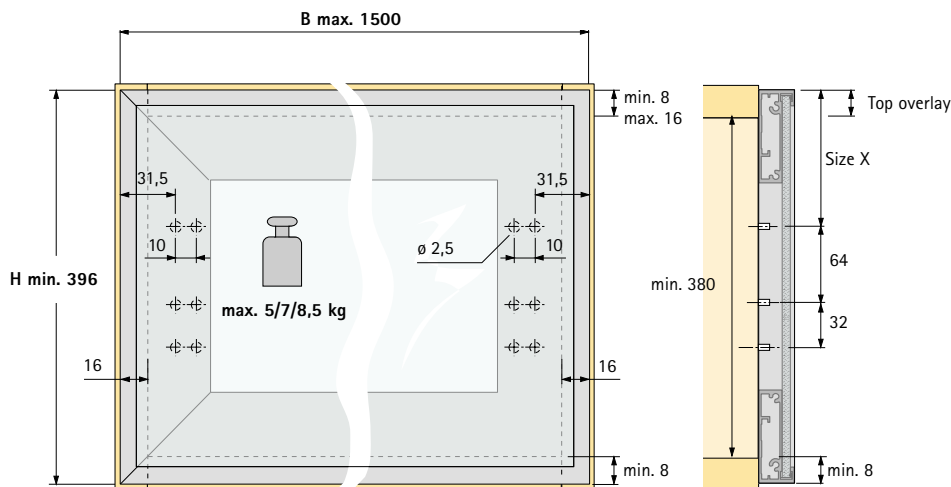

## Attention:

Use a separate order sheet for each frame size/door size. Please specify all measurements in mm.

|                            |  |
|----------------------------|--|
| <b>H</b><br>min. 396       |  |
| <b>B</b><br>max. 1500      |  |
| <b>Size X</b><br>see below |  |
| <b>Number of doors</b>     |  |

|                     |     |     |     |     |     |     |     |     |     |
|---------------------|-----|-----|-----|-----|-----|-----|-----|-----|-----|
| <b>Side overlay</b> | 16  |     |     |     |     |     |     |     |     |
| <b>Top overlay</b>  | 8   | 9   | 10  | 11  | 12  | 13  | 14  | 15  | 16  |
| <b>Size X</b>       | 205 | 206 | 207 | 208 | 209 | 210 | 211 | 212 | 213 |

### Aluminium frame profile set, width 55 mm, straight made to measure

contains: 4 aluminium frame profiles, silver anodised  
4 sealing profiles for 4 mm gauge glass

| Order no. | PU    | Door perimeter mm | Number of doors |
|-----------|-------|-------------------|-----------------|
| 041 284   | 1 set |                   |                 |

### Fabrication for an aluminium frame, width 55 mm, straight

contains: mitre cuts, including cutting to length  
drill holes for mitre joint  
4 angle connectors  
8 countersunk screws

| Order no. | PU | Number of doors |
|-----------|----|-----------------|
| 041 288   | 1  |                 |

### Fabrication for vertical lift-up flap fitting, width adjustable with 2 gas pressure springs (for one door)

contains: 12 drill holes

| Order no. | PU | Number of doors |
|-----------|----|-----------------|
| 041 598   | 1  |                 |

### Vertical lift-up flap fitting, width adjustable with pneumatic action

| Order no.<br>white | aluminium finish | Inside cabinet width  | Max. flap weight | Stock    | Order quantity |
|--------------------|------------------|---|------------------|----------|----------------|
| 013 886            | 045 033          | 450 - 870 mm  | 5,0 kg           | Retailer |                |
| 013 887            | 045 034          | 450 - 1170 mm   | 7,0 kg           | Retailer |                |
| 013 888            | 045 035          | 450 - 1470 mm   | 8,5 kg           | Retailer |                |
| 041 331            |                  | Special countersunk self-tapping screw $\varnothing$ 3,9 x 9,5 mm |                  | Retailer |                |

Joiner/interior fitter:

Date: \_\_\_\_\_ Signature: \_\_\_\_\_

# Lift-up flap fitting width adjustable with 2 adjustable gas pressure springs

3



## Adjustable width flap fitting allows front to swivel up gently over the cabinet

Ideal for microwaves, grills, electrical appliances, crockery and glasses. The two gas pressure springs assist the mechanism to hold the front securely in the open position and close it firmly. The opening/closing force is adjustable to adapt the fitting to different flap weights. Use of ball bearings and gas pressure springs ensures minimum effort when opening and closing the flaps.

- Width adjustable to inside cabinet widths of 300 mm to 1800 mm
- Dual pneumatic action
- Opening / closing force adjustable
- Optimal access
- Efficient assembly, the door/flap is simply clipped on and screwed tight
- Three-dimensional front adjustment  
Height +4, side ±2, angle +4
- Max. flap/door weight 12 kg
- Minimum internal cabinet dimensions:  
Width: 300 mm - 1800 mm  
Height: 390 mm - 680 mm  
Depth: 195 mm
- Finish: plastic-coated steel, aluminium finish



| Article  | Order no. | PU    |
|--|-----------|-------|
| Cross rail reverser set for use with aluminium frame | 048 105   | 1 set |

| Article  | Inside cabinet width of | Max. flap weight | Order no. aluminium finish | PU    |
|--|-------------------------|------------------|----------------------------|-------|
| Vertical lift-up flap fitting width adjustable with pneumatic action | 300 - 600 mm            | 5,0 - 7,0 kg     | 048 079                    | 1 set |
|  | 600 - 1200 mm           | 7,0 - 9,0 kg     | 048 081                    | 1 set |
|  | 1200 - 1800 mm          | 9,0 - 12,0 kg    | 048 082                    | 1 set |

Set contains: fitting, cross rail, screws

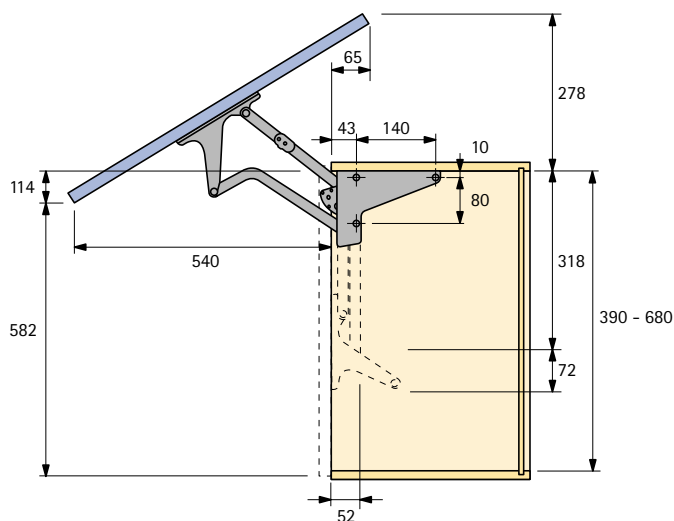
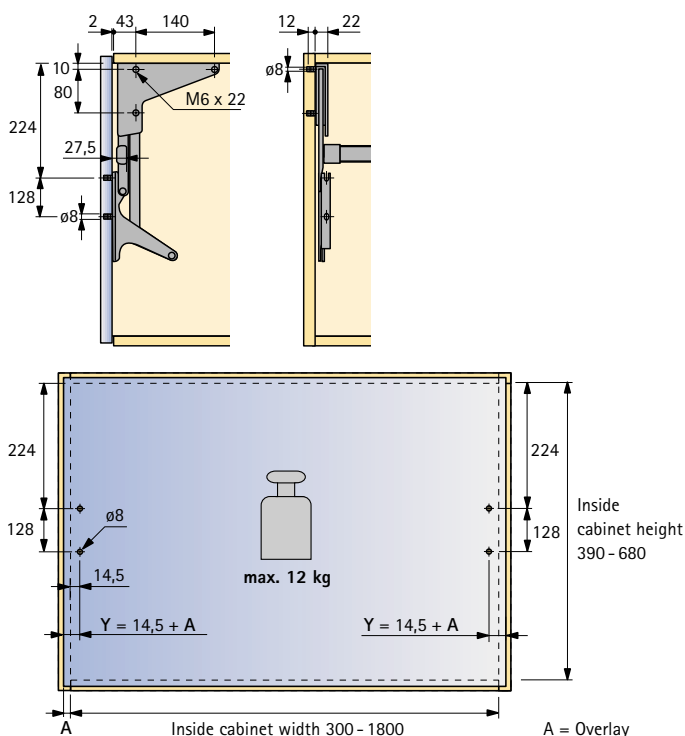

# Lift-up flap fitting width adjustable with 2 adjustable gas pressure springs

## Mounting with wooden flap

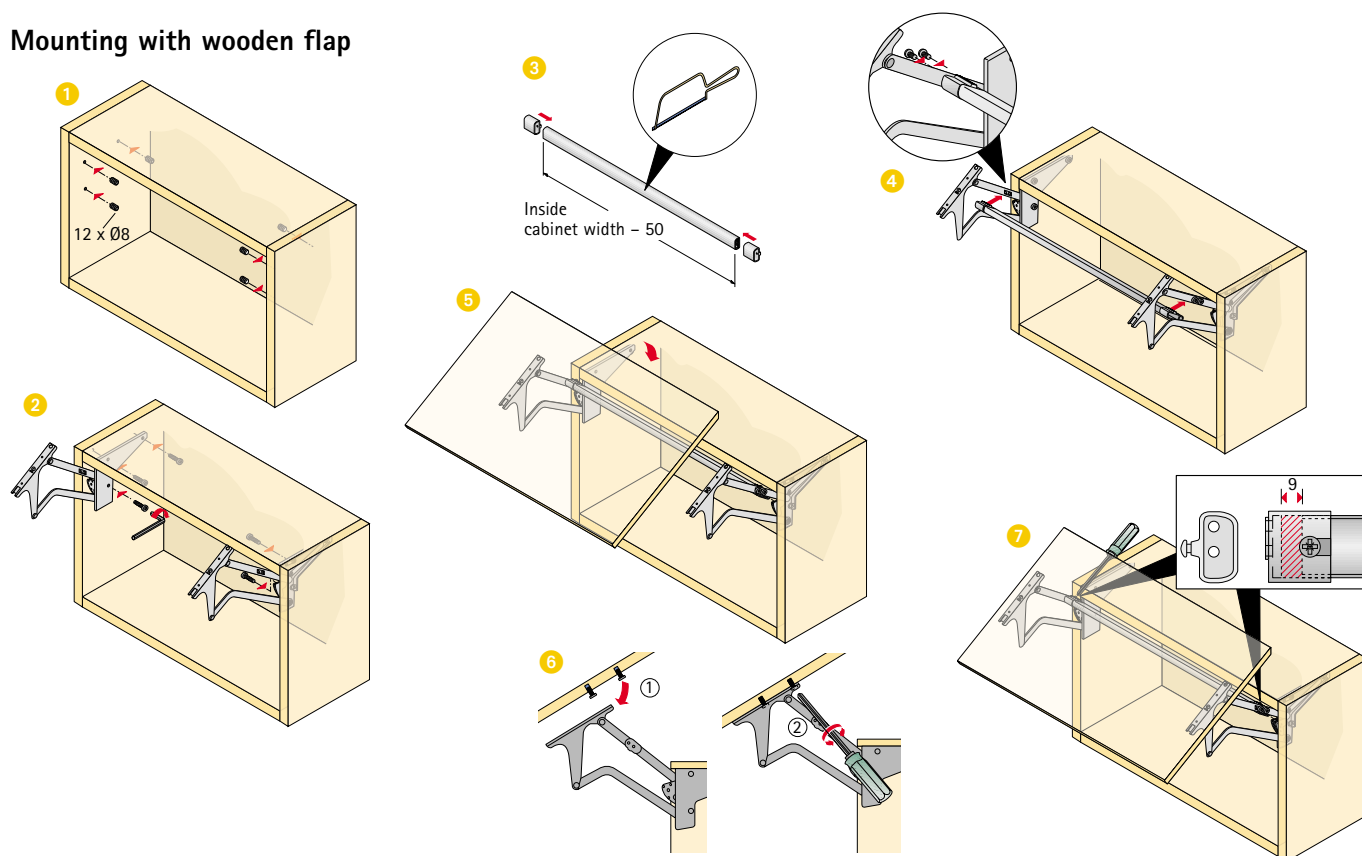

3

## Assembly with aluminium frame profile

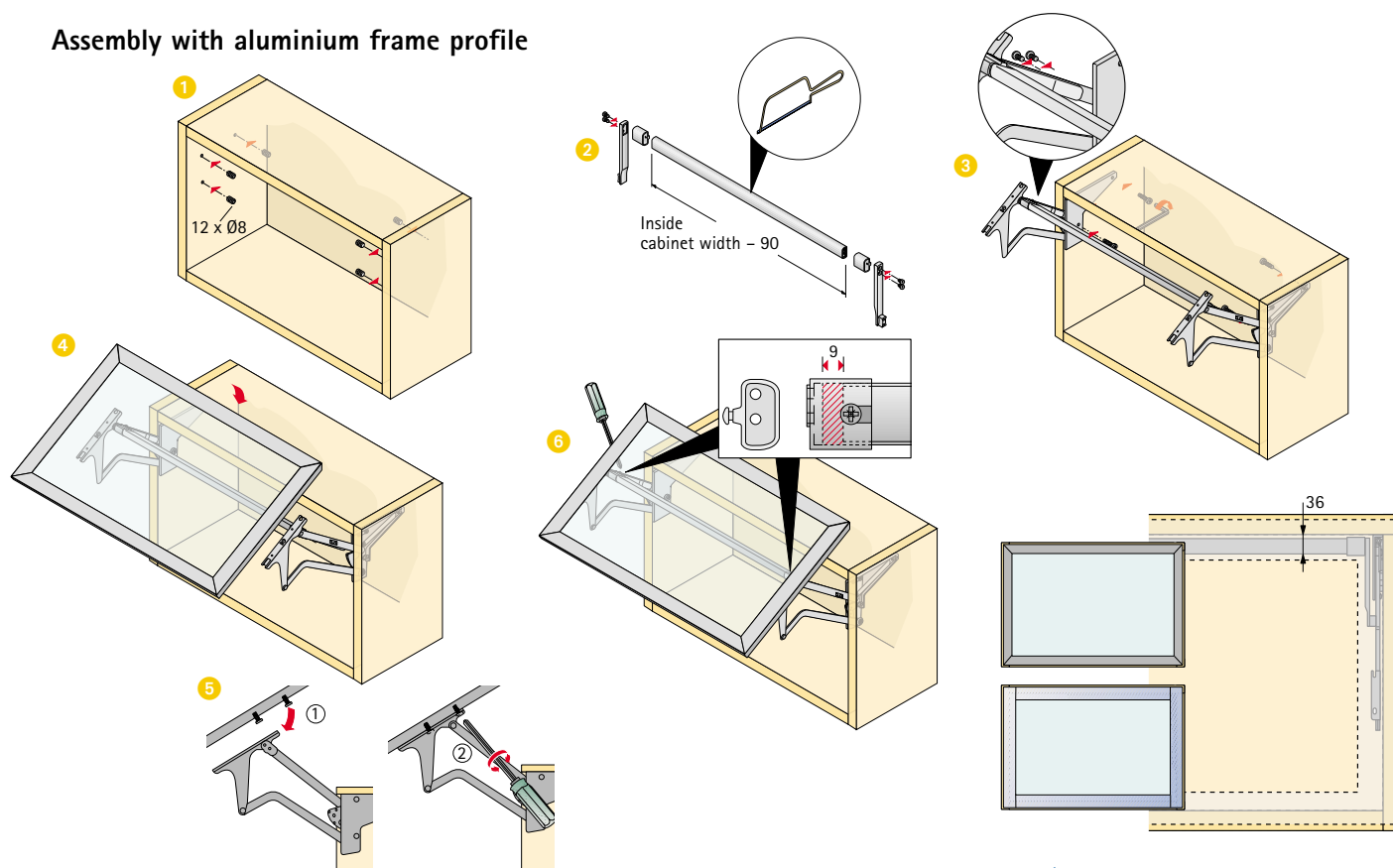

# Aluminium frame profile

## Width 55 mm, curved, for vertical lift-up flap fitting

### width adjustable, with 2 adjustable gas pressure springs

Can be customised to size or supplied ready made up



This profile can be customised to size by the customer.

- Silver anodised surface
- Usable with 4 and 5 mm glass thickness
- Safe installation with fixing angles and screws

Cross-section

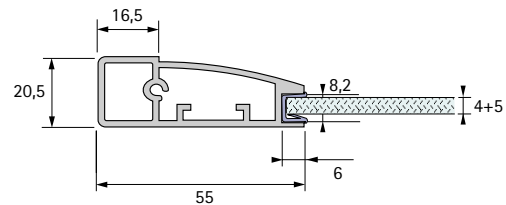

Aluminium frame profile,  
width 55 mm, curved  
silver anodised



Sealing strip  
for glass thickness 4 and 5 mm  
Plastic, transparent



Angle set

contains:  
4 fixing angles  
8 fixing screws



| Length  | Order no. | PU |
|---------|-----------|----|
| 6000 mm | 013 430   | 4  |
| 3000 mm | 020 035   | 4  |

| Length  | Order no. | PU |
|---------|-----------|----|
| 3500 mm | 075 620   | 1  |

| Article   | Order no. | PU    |
|-----------|-----------|-------|
| Angle set | 013 684   | 1 set |

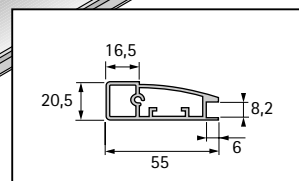
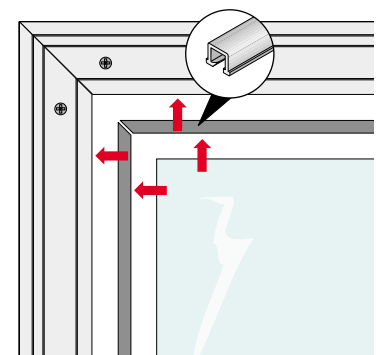
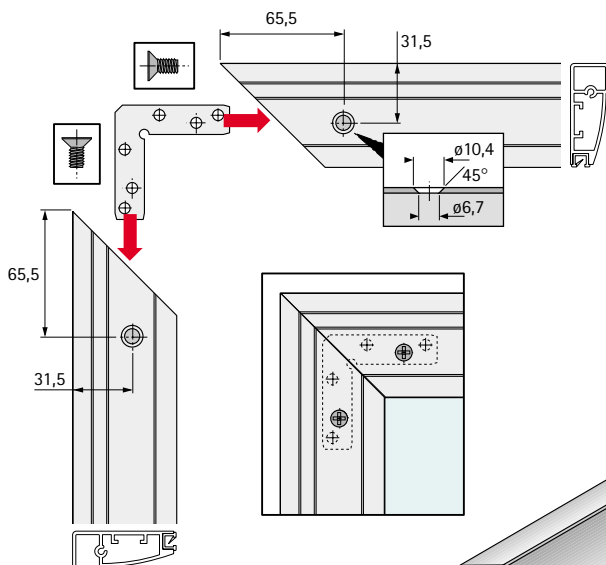

Glass cutting dimension =  
door width/height - 102 mm

# Fax order to your specialist retailer

Simply fill in the fax form to receive a set of aluminium frame profiles fully customised to your dimensions, width 55 mm, curved

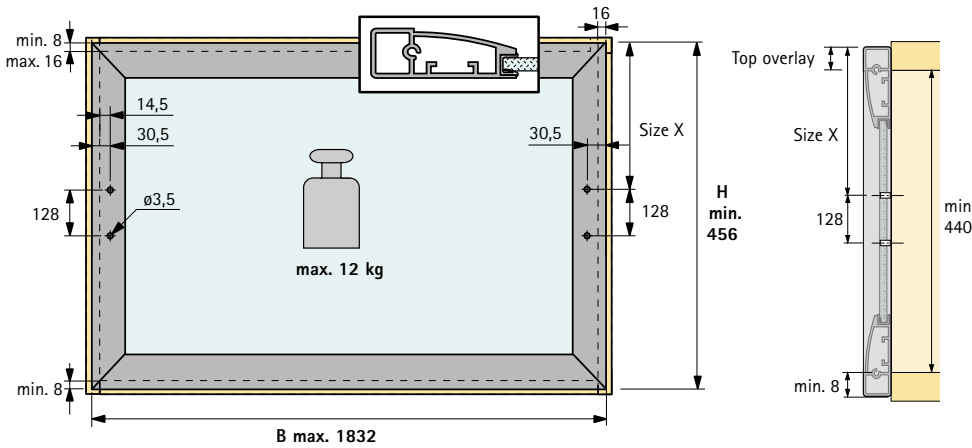

## Attention:

Use a separate order sheet for each frame size/door size. Please specify all measurements in mm.

|                            |  |
|----------------------------|--|
| <b>H</b><br>min. 456       |  |
| <b>B</b><br>max. 1832      |  |
| <b>Size X</b><br>see below |  |
| <b>Number of doors</b>     |  |

|                     |     |     |     |     |     |     |     |     |     |  |
|---------------------|-----|-----|-----|-----|-----|-----|-----|-----|-----|--|
| <b>Side overlay</b> | 16  |     |     |     |     |     |     |     |     |  |
| <b>Top overlay</b>  | 8   | 9   | 10  | 11  | 12  | 13  | 14  | 15  | 16  |  |
| <b>Size X</b>       | 232 | 233 | 234 | 235 | 236 | 237 | 238 | 239 | 240 |  |

**Aluminium frame profile set, width 55 mm, curved made to measure**  
contains: 4 aluminium frame profiles, silver anodised  
4 sealing profiles for 4 mm and 5 mm gauge glass

| Order no. | PU    | Door perimeter mm | Number of doors |
|-----------|-------|-------------------|-----------------|
| 041 283   | 1 set |                   |                 |

**Fabrication for an aluminium frame, width 55 mm, curved**  
contains: mitre cuts, including cutting to length  
drill holes for mitre joint  
4 angle connectors  
8 countersunk screws

| Order no. | PU | Number of doors |
|-----------|----|-----------------|
| 041 287   | 1  |                 |

**Fabrication for lift-up flap fitting, width adjustable with 2 adjustable gas pressure springs (for one door)**  
contains: 4 drill holes

| Order no. | PU | Number of doors |
|-----------|----|-----------------|
| 041 596   | 1  |                 |

## Lift-up flap fitting, width adjustable with 2 adjustable gas pressure springs

| Order no. | Inside cabinet width                                 | Max. flap weight | Stock    | Order quantity |
|-----------|--|------------------|----------|----------------|
| 048 079   | 300 - 600 mm   | 5,0 - 7,0 kg     | Retailer |                |
| 048 081   | 600 - 1200 mm  | 7,0 - 9,0 kg     | Retailer |                |
| 048 082   | 1200 - 1800 mm                                       | 9,0 - 12,0 kg    | Retailer |                |
| 048 105   | Cross rail reverser set                              |                  | Retailer |                |
| 041 329   | Special countersunk self-tapping screw ø 4,8 x 13 mm |                  | Retailer |                |

Joiner/interior fitter:

Date: \_\_\_\_\_ Signature: \_\_\_\_\_

# Aluminium frame profile

## Width 55 mm, straight, for vertical lift-up flap fitting, width adjustable, with 2 adjustable gas pressure springs

Can be customised to size or supplied ready made up



This profile can be customised to size by the customer.

- Silver anodised surface
- Usable with 4 mm glass thickness
- Can be cut to individually required lengths
- Safe installation with fixing angles and screws

Cross-section

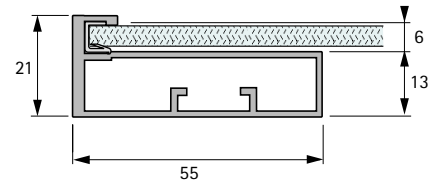

3

### Aluminium frame profile set, width 55 mm, straight

contains:

- 1 aluminium frame profile, silver anodised
- 1 sealing strip for glass thickness 4 mm  
Plastic, transparent



### Angle set

contains:

- 4 fixing angles
- 8 fixing screws

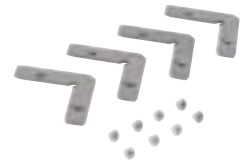

| Length mm | Order no. | PU    |
|-----------|-----------|-------|
| 3000      | 020 401   | 1 set |

| Article   | Order no. | PU    |
|-----------|-----------|-------|
| Angle set | 013 684   | 1 set |

### Assembly of aluminium frame profile, width 55 mm

Glass cutting dimension = door width/height - 7 mm

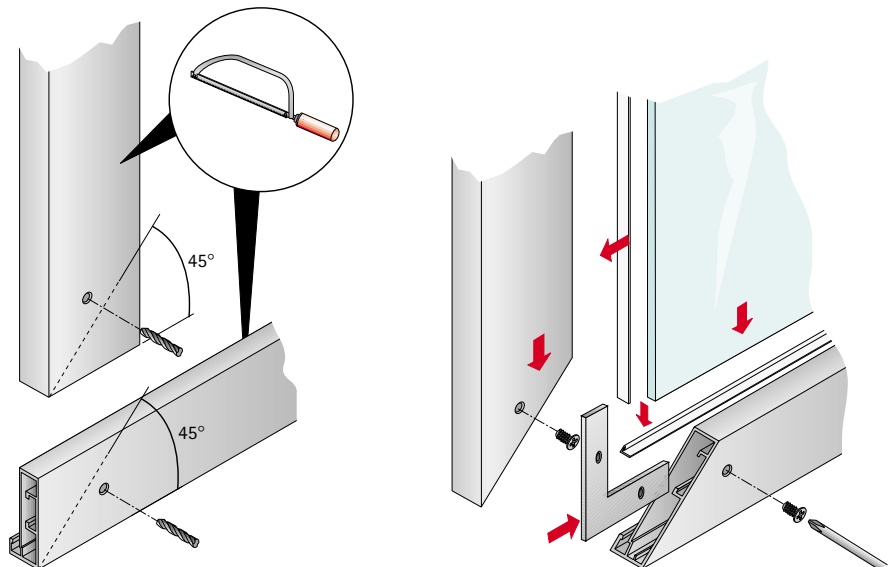
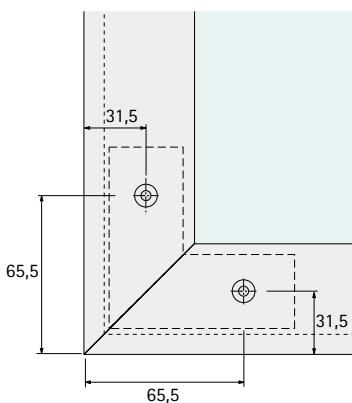

# Fax order to your specialist retailer

Simply fill in the fax form to receive a set of aluminium frame profiles fully customised to your dimensions, width 55 mm, straight

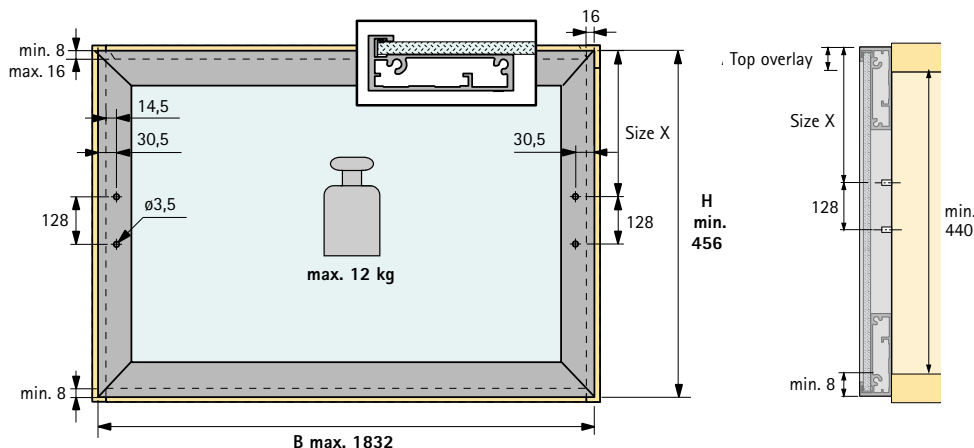

### Attention:

Use a separate order sheet for each frame size/door size. Please specify all measurements in mm.

|                            |  |
|----------------------------|--|
| <b>H</b><br>min. 456       |  |
| <b>B</b><br>max. 1832      |  |
| <b>Size X</b><br>see below |  |
| <b>Number of doors</b>     |  |

|              |     |     |     |     |     |     |     |     |     |  |
|--------------|-----|-----|-----|-----|-----|-----|-----|-----|-----|--|
| Side overlay | 16  |     |     |     |     |     |     |     |     |  |
| Top overlay  | 8   | 9   | 10  | 11  | 12  | 13  | 14  | 15  | 16  |  |
| Size X       | 232 | 233 | 234 | 235 | 236 | 237 | 238 | 239 | 240 |  |

**Aluminium frame profile set, width 55 mm, straight made to measure**  
contains: 4 aluminium frame profiles, silver anodised  
4 sealing profiles for 4 mm gauge glass

| Order no. | PU    | Door perimeter mm | Number of doors |
|-----------|-------|-------------------|-----------------|
| 041 284   | 1 set |                   |                 |

**Fabrication for an aluminium frame, width 55 mm, straight**  
contains: mitre cuts, including cutting to length  
drill holes for mitre joint  
4 angle connectors  
8 countersunk screws

| Order no. | PU | Number of doors |
|-----------|----|-----------------|
| 041 288   | 1  |                 |

**Fabrication for lift-up flap fitting, width adjustable with 2 adjustable gas pressure springs (for one door)**  
contains: 4 drill holes

| Order no. | PU | Number of doors |
|-----------|----|-----------------|
| 041 595   | 1  |                 |

**Lift-up flap fitting, width adjustable with 2 adjustable gas pressure springs**

| Order no. | Inside cabinet width   | Max. flap weight | Stock    | Order quantity |
|-----------|--|------------------|----------|----------------|
| 048 079   | 300 - 600 mm   | 5,0 - 7,0 kg     | Retailer |                |
| 048 081   | 600 - 1200 mm  | 7,0 - 9,0 kg     | Retailer |                |
| 048 082   | 1200 - 1800 mm   | 9,0 - 12,0 kg    | Retailer |                |
| 048 105   | Cross rail reverser set  |                  | Retailer |                |
| 041 329   | Special countersunk self-tapping screw $\varnothing$ 4,8 x 13 mm |                  | Retailer |                |

Joiner/interior fitter:

Date: \_\_\_\_\_ Signature: \_\_\_\_\_

# Fold-lift fitting

3



## The fold-lift fitting gets things moving in the kitchen,

by enabling two furniture fronts of equal horizontal size to swivel upwards for easy access to the interior of the cabinet. A gentle pull on the handle is all that's needed to lift the two parts of the door gently upwards, automatically.

This fitting is suitable for wall cabinets up to 1200 mm wide and 520 mm high.

Straightforward connecting technology for easy handling and assembly.

- Optimal access
- **Max. flap/door weight 11,5 kg**
- **Minimum cabinet dimensions:**  
 max. width: 1200 mm  
 height: 520 mm  
 min. depth: 250 mm
- **Three-dimensional front adjustment via Intermat 9943 hinge, see page 3.26**
- Finish: plastic-coated steel, aluminium finish



| Article                        | Max. cabinet width | Cabinet height | Weight per door kg | Order no. | PU    |
|--------------------------------|--------------------|----------------|--------------------|-----------|-------|
| Fold-lift fitting<br>1 fitting | 600 mm             | 520 mm         | 4,0                | 046 643   | 1 set |
|                                | 600 mm             | 520 mm         | 5,0                | 046 644   | 1 set |
|                                | 600 mm             | 520 mm         | 6,0                | 046 645   | 1 set |
| 2 fittings                     | 600 mm             | 520 mm         | 7,0                | 046 646   | 1 set |
|                                | 600-1200 mm        | 520 mm         | 7,5                | 046 647   | 1 set |
|                                | 600-1200 mm        | 520 mm         | 8,5                | 046 648   | 1 set |
|                                | 600-1200 mm        | 520 mm         | 10,0               | 046 649   | 1 set |
|                                | 600-1200 mm        | 520 mm         | 11,5               | 046 650   | 1 set |

Set contains one right-hand or one right-hand and one left-hand fitting

## Assembly

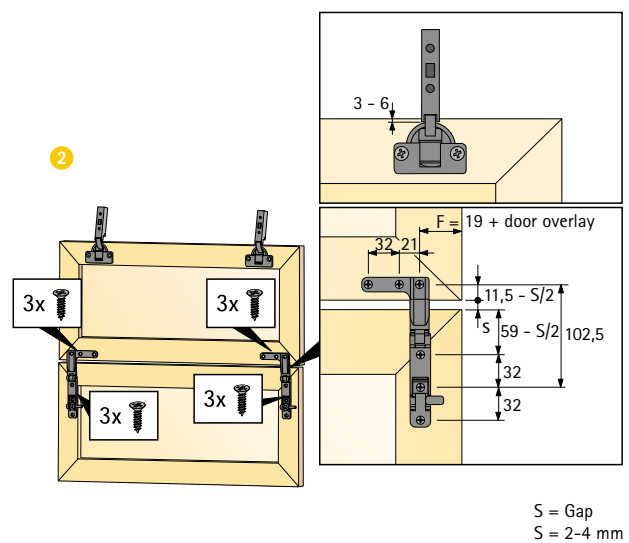
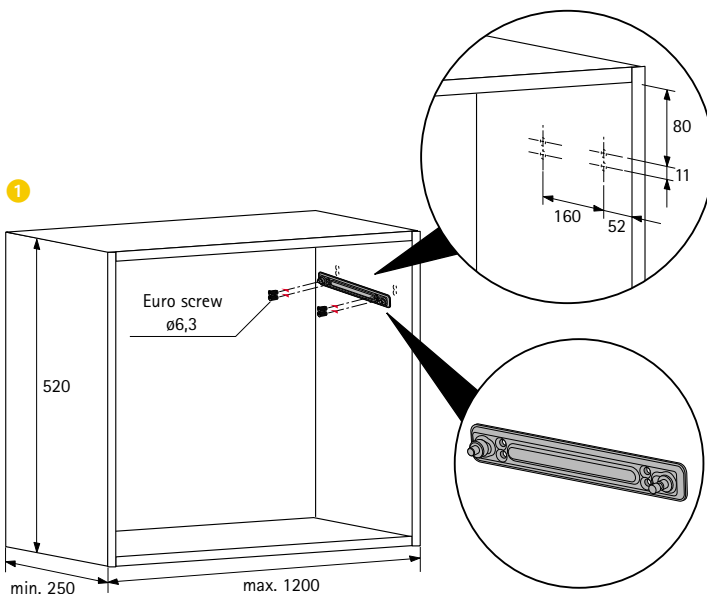

S = Gap  
S = 2-4 mm

# Fold-lift fitting

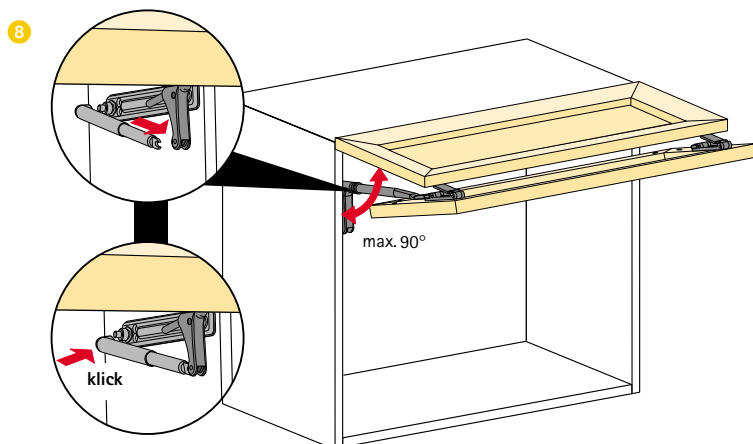
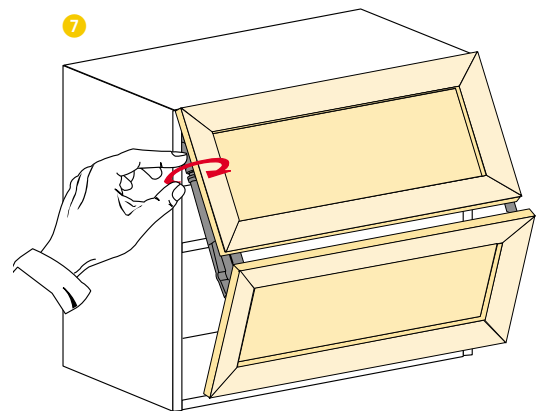
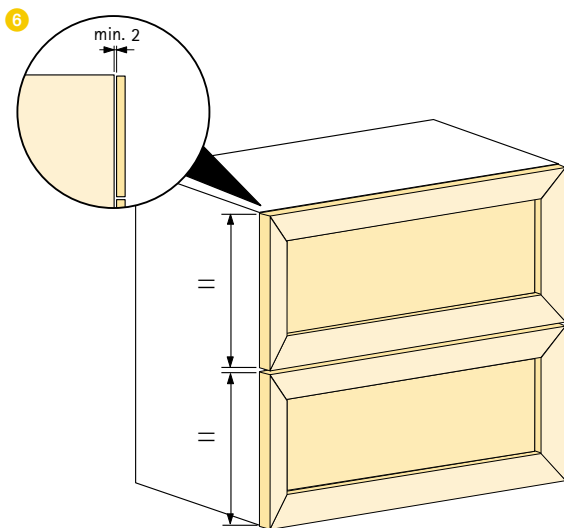
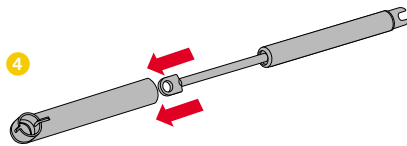
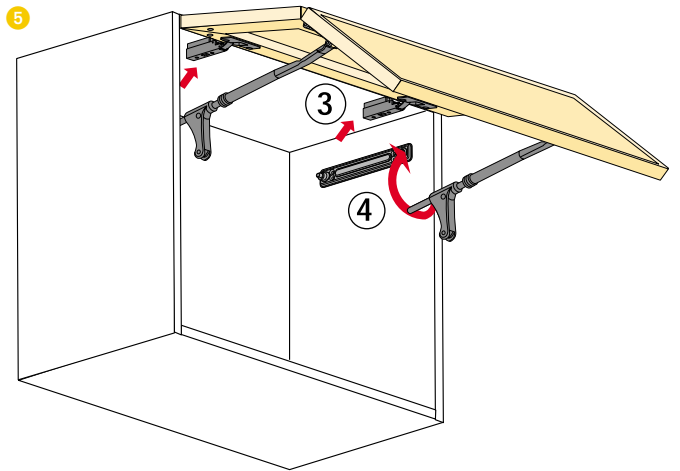
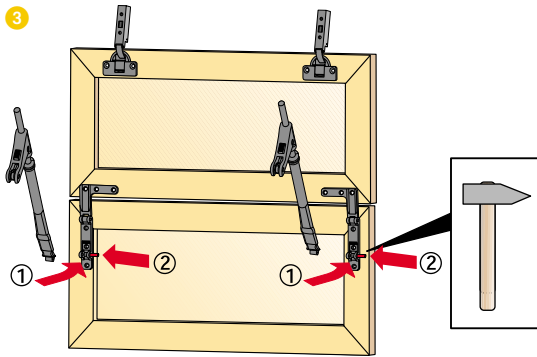

# Swivel fitting Horizon Plus

3



## Swivel fitting Horizon Plus

**Innovative swivel fitting for furniture which allows doors to open horizontally.**

Horizon Plus allows full use to be made of the cupboard interior, as the fitting swivels the door completely in front of the cabinet.

No door protrusion up to 600 mm carcass width

Cross rail can be customised for door heights up to 2600 mm.

Horizon Plus can be used in various cabinet designs, as a single or double door and even corner cabinet solutions.

Aluminium framed doors can be used as an alternative to wooden fronts.

### Inside cabinet dimensions:

Door heights up to 2570 mm

Door widths from 475 mm to 600 mm, no door protrusion

Door width max. 700 mm, door protrusion 100 mm

Max. depth 60 mm

**Max. door weight 20 kg**

**Three-dimensional front adjustment**

Height +4 mm, side  $\pm 2$  mm, angle +4 mm



| Article                        | Inside cabinet width       | Inside cabinet height | Max. door weight of kg | Order no.          | PU             |
|--------------------------------|----------------------------|-----------------------|------------------------|--------------------|----------------|
| Swivel fitting<br>Horizon Plus | 475- 700 mm<br>475- 700 mm | 1570 mm<br>2570 mm    | 20<br>20               | 048 077<br>048 078 | 1 set<br>1 set |

**Set contains:** fitting, cross rail, screws

# Swivel fitting Horizon Plus

## Cabinet design

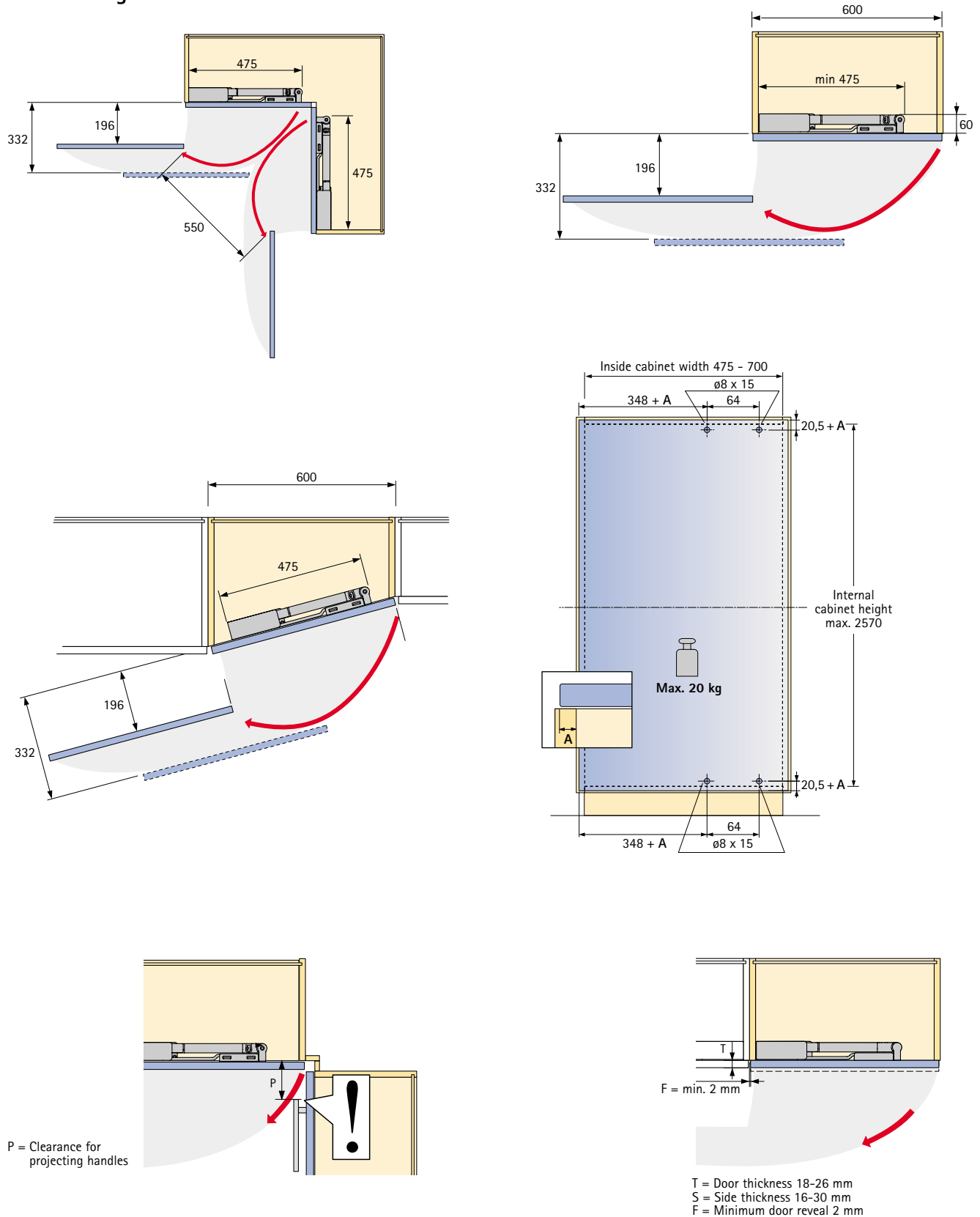

# Swivel fitting Horizon Plus

## Assembly

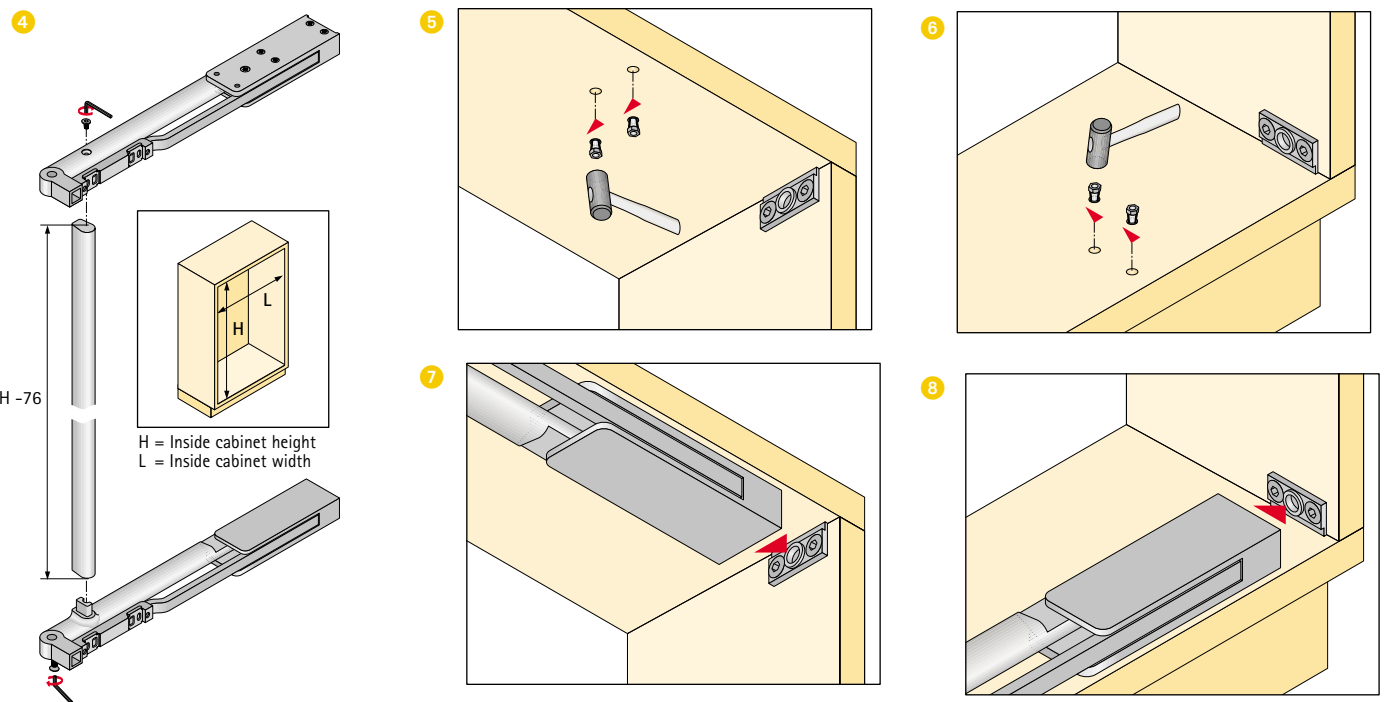
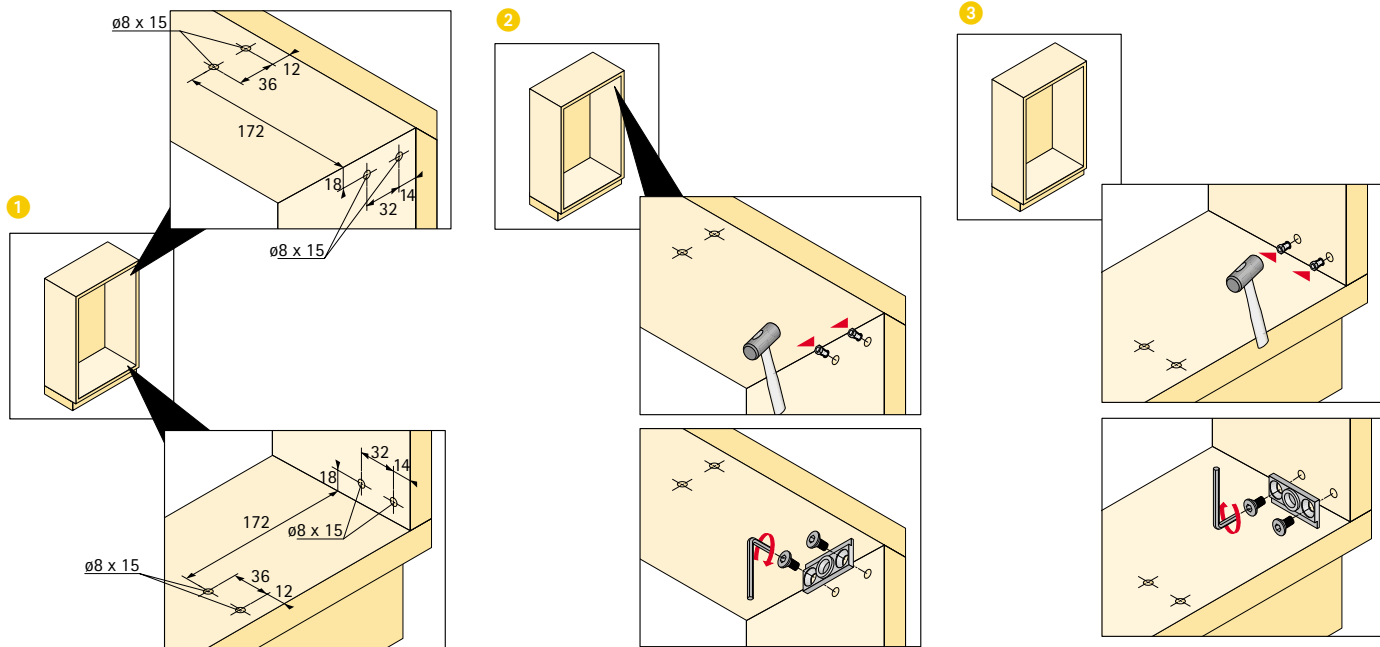

# Swivel fitting Horizon Plus

## Assembly

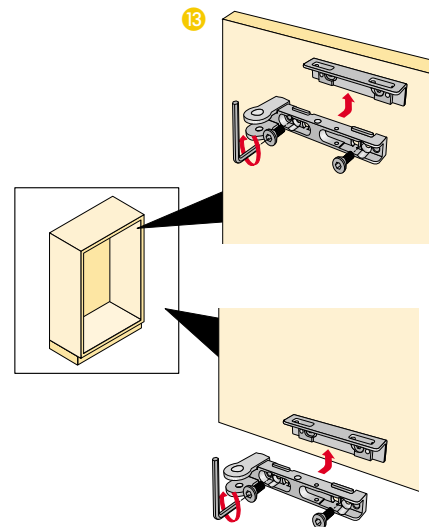
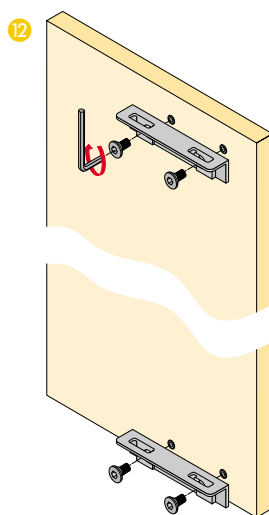
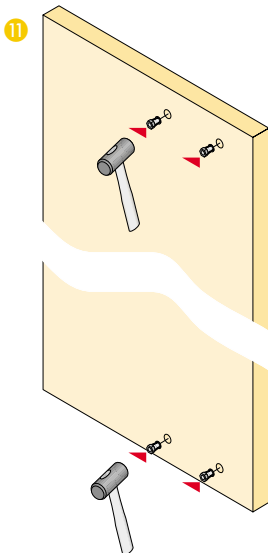
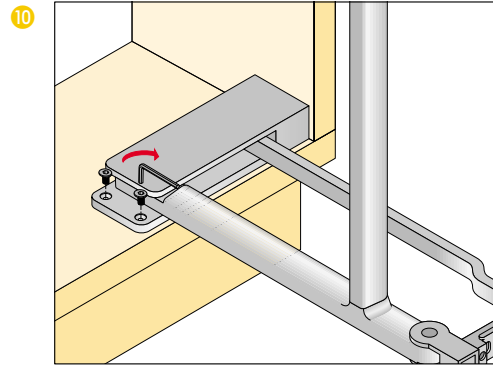
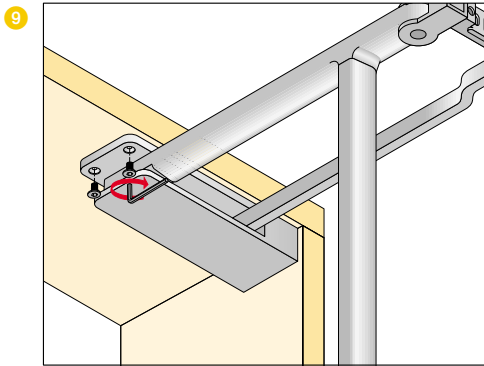

3

## Front adjustment

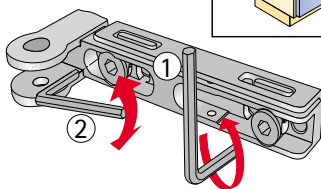
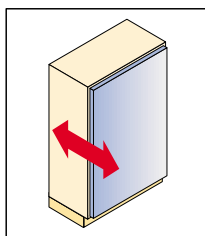

Door angle  
adjustment + 4 mm

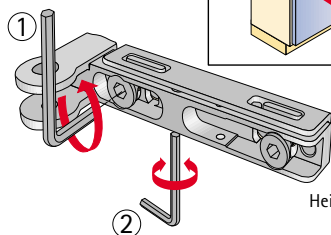
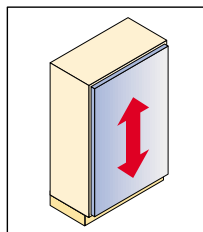

Height adjustment + 4 mm

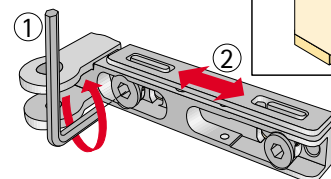
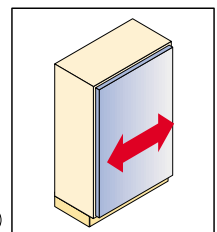

Width adjustment  $\pm 2$  mm

# Aluminium frame profile

## Width 55 mm, curved

### for horizontal swivel fitting Horizon Plus

Can be customised to size or supplied ready made up



This profile can be customised to size by the customer.

- Silver anodised surface
- Usable with 4 and 5 mm glass thickness
- Safe installation with fixing angles and screws

Cross-section

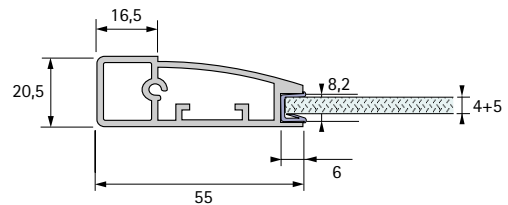

Aluminium frame profile,  
width 55 mm, curved  
silver anodised



Sealing strip  
for glass thickness 4 and 5 mm  
Plastic, transparent



Angle set

contains:  
4 fixing angles  
8 fixing screws



| Length  | Order no. | PU |
|---------|-----------|----|
| 6000 mm | 013 430   | 4  |
| 3000 mm | 020 035   | 4  |

| Length  | Order no. | PU |
|---------|-----------|----|
| 3500 mm | 075 620   | 1  |

| Article   | Order no. | PU    |
|-----------|-----------|-------|
| Angle set | 013 684   | 1 set |

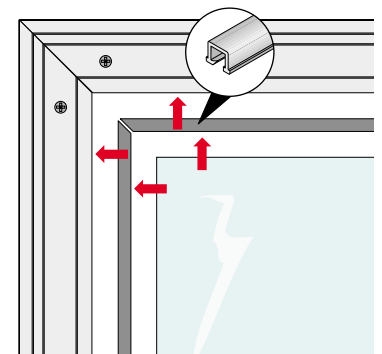
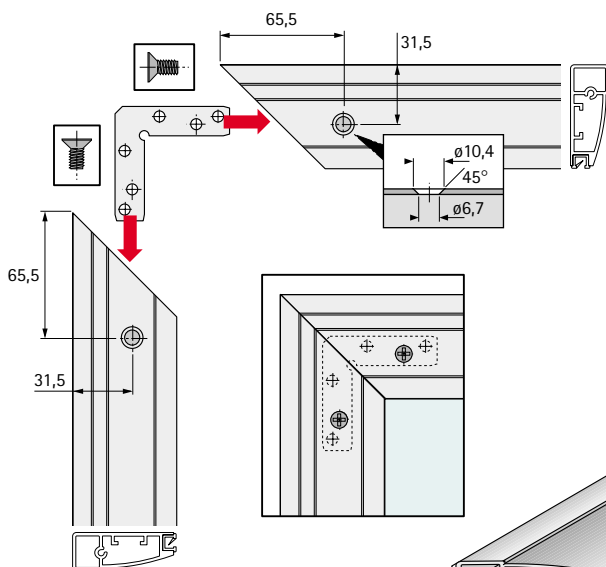

Glass cutting dimension =  
door width/height - 102 mm

# Fax order to your specialist retailer

Simply fill in the fax form to receive a set of aluminium frame profiles fully customised to your dimensions, width 55 mm, curved

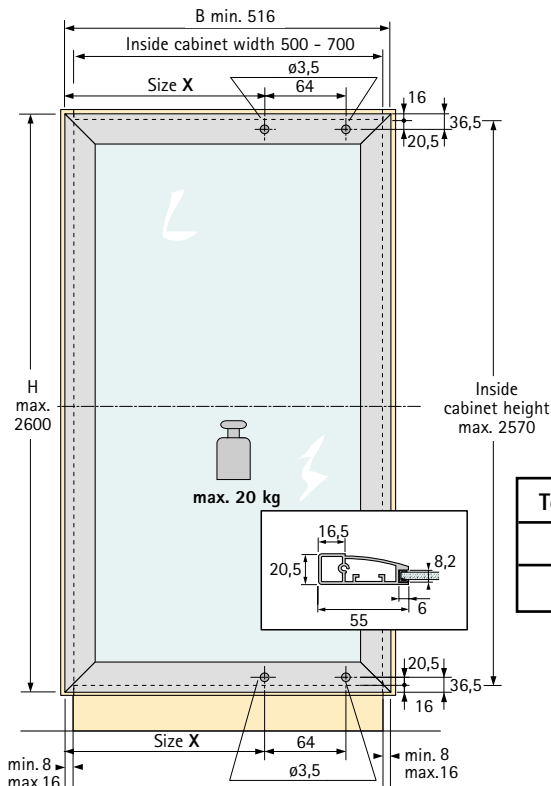

Left-hand door illustrated.  
Left-hand and right-hand doors are identical.

## Attention:

Use a separate order sheet for each frame size/door size. Please specify all measurements in mm.

|                            |  |
|----------------------------|--|
| <b>H</b><br>max. 2600      |  |
| <b>B</b><br>min. 516       |  |
| <b>Size X</b><br>see below |  |
| <b>Number of doors</b>     |  |

|                           |     |     |     |     |     |     |     |     |     |
|---------------------------|-----|-----|-----|-----|-----|-----|-----|-----|-----|
| <b>Top/bottom overlay</b> | 16  |     |     |     |     |     |     |     |     |
| <b>Side overlay</b>       | 8   | 9   | 10  | 11  | 12  | 13  | 14  | 15  | 16  |
| <b>Size X</b>             | 356 | 357 | 358 | 359 | 360 | 361 | 362 | 363 | 364 |

## Aluminium frame profile set, width 55 mm, curved made to measure

contains: 4 aluminium frame profiles, silver anodised  
4 sealing profiles for 4 mm and 5 mm gauge glass

| Order no. | PU    | Door perimeter mm | Number of doors |
|-----------|-------|-------------------|-----------------|
| 041 283   | 1 set |                   |                 |

## Fabrication for an aluminium frame, width 55 mm, curved

contains: mitre cuts, including cutting to length  
drill holes for mitre joint  
4 angle connectors  
8 countersunk screws

| Order no. | PU | Number of doors |
|-----------|----|-----------------|
| 041 287   | 1  |                 |

## Fabrication for swivel fitting Horizon Plus (for one door)

contains: drill holes

| Order no. | PU | Number of doors |
|-----------|----|-----------------|
| 041 596   | 1  |                 |

## Swivel fitting Horizon Plus

| Order no. | Inside cabinet width                                 | Inside cabinet height | Max. door weight of | Stock    | Order quantity |
|-----------|--|-----------------------|---------------------|----------|----------------|
| 048 077   | 500 - 700 mm   | 1570 mm               | 20,0 kg             | Retailer |                |
| 048 078   | 500 - 700 mm   | 2570 mm               | 20,0 kg             | Retailer |                |
| 041 329   | Special countersunk self-tapping screw ø 4,8 x 13 mm |                       |                     | Retailer |                |

Joiner/interior fitter:

Date: \_\_\_\_\_ Signature: \_\_\_\_\_

# Aluminium frame profile

## Width 55 mm, straight

### for swivel fitting Horizon Plus

Can be customised to size or supplied ready made up



This profile can be customised to size by the customer.

- Silver anodised surface
- Usable with 4 mm glass thickness
- Can be cut to individually required lengths
- Safe installation with fixing angles and screws

Cross-section

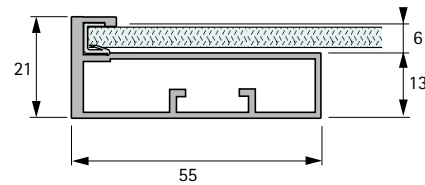

3

#### Aluminium frame profile set, width 55 mm, straight

contains:

- 1 aluminium frame profile, silver anodised
- 1 sealing strip for glass thickness 4 mm, transparent plastic



#### Angle set

contains:

- 4 fixing angles
- 8 fixing screws

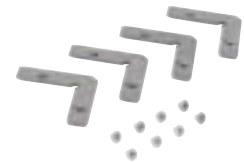

| Length mm | Order no. | PU    |
|-----------|-----------|-------|
| 3000      | 020 401   | 1 set |

| Article   | Order no. | PU    |
|-----------|-----------|-------|
| Angle set | 013 684   | 1 set |

Glass cutting dimension = door width/height - 7 mm

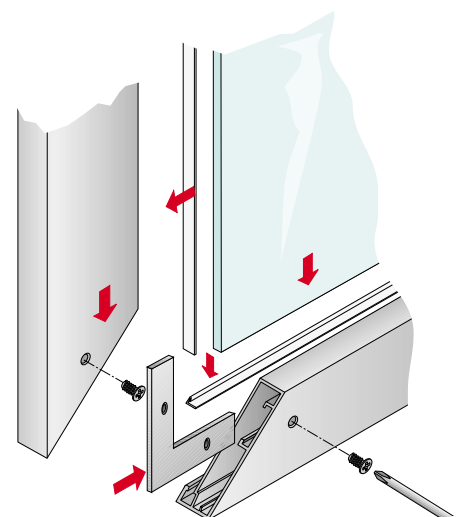
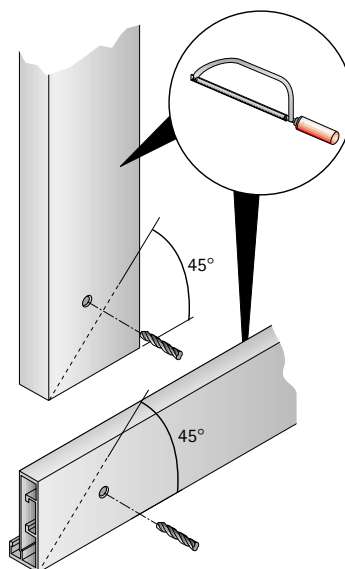
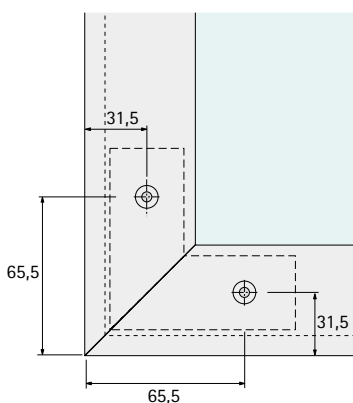

# Fax order to your specialist retailer

Simply fill in the fax form to receive a set of aluminium frame profiles fully customised to your dimensions, width 55 mm, straight

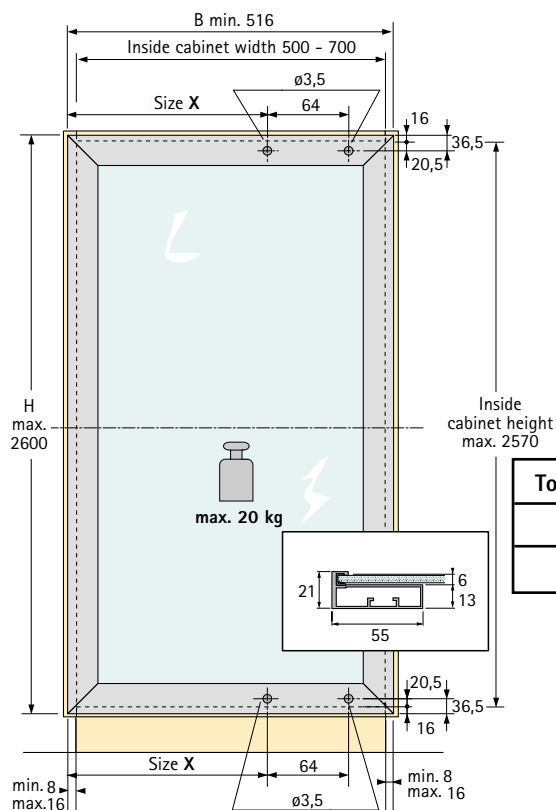

Left-hand door illustrated.  
Left-hand and right-hand doors are identical.

**Fabrication for an aluminium frame, width 55 mm, straight**  
contains: mitre cuts, including cutting to length  
drill holes for mitre joint  
4 angle connectors  
8 countersunk screws

| Order no. | PU | Number of doors |
|-----------|----|-----------------|
| 041 288   | 1  |                 |

## Attention:

Use a separate order sheet for each frame size/door size. Please specify all measurements in mm.

|                            |  |
|----------------------------|--|
| <b>H</b><br>max. 2600      |  |
| <b>B</b><br>min. 516       |  |
| <b>Size X</b><br>see below |  |
| <b>Number of doors</b>     |  |

| Top/bottom overlay | 16  |     |     |     |     |     |     |     |     |
|--------------------|-----|-----|-----|-----|-----|-----|-----|-----|-----|
| Side overlay       | 8   | 9   | 10  | 11  | 12  | 13  | 14  | 15  | 16  |
| Size X             | 356 | 357 | 358 | 359 | 360 | 361 | 362 | 363 | 364 |

## Aluminium frame profile set, width 55 mm, straight made to measure

contains: 4 aluminium frame profiles, silver anodised  
4 sealing profiles for 4 mm gauge glass

| Order no. | PU    | Door perimeter mm | Number of doors |
|-----------|-------|-------------------|-----------------|
| 041 284   | 1 set |                   |                 |

## Fabrication for swivel fitting Horizon Plus (for one door)

contains: 4 drill holes

| Order no. | PU | Number of doors |
|-----------|----|-----------------|
| 041 595   | 1  |                 |

## Swivel fitting Horizon Plus

| Order no. | Inside cabinet width                                 | Inside cabinet height | Max. door weight of | Stock    | Order quantity |
|-----------|--|-----------------------|---------------------|----------|----------------|
| 048 077   | 500 - 700 mm   | 1570 mm               | 20,0 kg             | Retailer |                |
| 048 078   | 500 - 700 mm   | 2570 mm               | 20,0 kg             | Retailer |                |
| 041 329   | Special countersunk self-tapping screw ø 4,8 x 13 mm |                       |                     | Retailer |                |

Joiner/interior fitter:

Date: \_\_\_\_\_ Signature: \_\_\_\_\_

